

## Control / Regulation

### Brinkmann coolant pumps with frequency converter 1.7 – 29.5 HP (1.3 – 22 kW)

Pumps with integrated frequency converter offer the optimum supplement to the existing product line for your application.

With the use of a frequency converter the Q/H curve which is typical for centrifugal pumps, is replaced by a performance curve array as shown in figure 1. This makes it possible to regulate the pump to various operating points within the performance curve array, allowing the pump to be optimally matched to your specific application.

### Pump Regulation

Regulation is an operation with which a physical value such as pressure is continuously measured and compared with a set value. In the event of deviation the regulation device (here a PI controller) provides for the desired adaptation.

With regulation a check is made whether a desired state is achieved or not. This allows a previously set pressure to be held constant within certain ranges in a process regardless of the flow quantities supplied.

### Pump control

Control is an operation in which a physical value such as pressure or flow rate is influenced by other values.

Within pump control we also speak of an open effective circuit, because the effect of the control is not monitored. Interferences occurring in the system cannot be compensated, because the output value has no effect on the input value.

Pumps with integrated frequency converter are always supplied preprogrammed by the manufacturer.

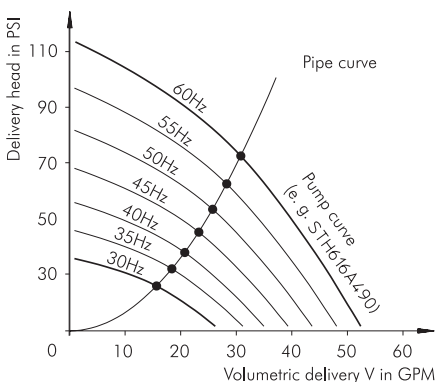

Fig. 1: Performance map

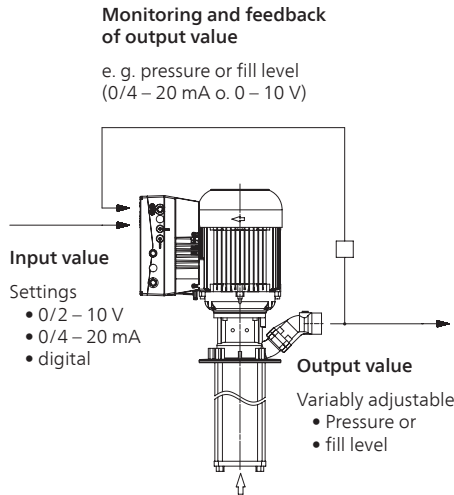

Fig. 2: Scheme of regulation

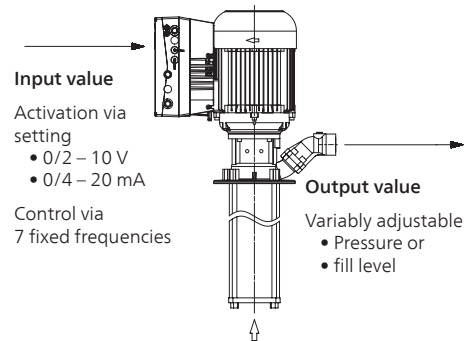

Fig. 4: Control scheme

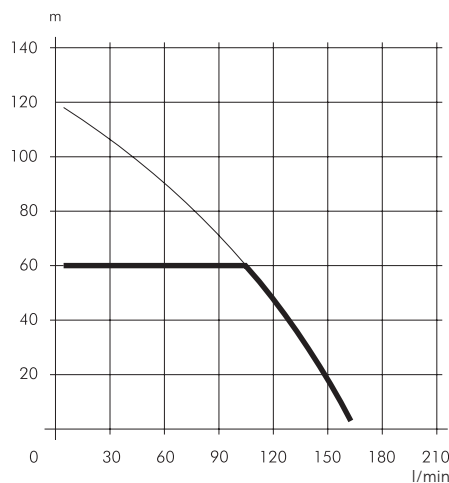

Fig. 3: Pressure regulation limited to max. 85 PSI (6 bar)

## Control / Regulation

### 1. Pump control via analog signal

When the coolant pump is controlled by using a frequency converter, nearly an infinite number of pressures can be achieved, for example, for different tools.

Usually the layout of the pump is limited to the 60 Hz version. Operation at higher frequencies is possible for various pumps with power reserves after consulting with the company.

The frequency converter is then operated at the current limit. This means the motor is operated at the set motor current rating at its maximum. If the pump requires more motor power for the operating point, the frequency is reduced until the max. motor current is reached again.

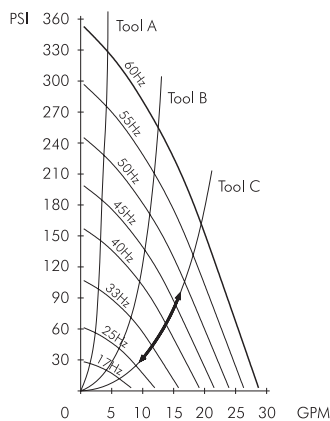

Fig. 5: Analog signal (infinite)

### 2. Pump control via fixed frequencies (max. 7)

An alternative to analog pump control is digital control of the frequency converter over 3 digital inputs. Here up to 7 different fixed frequencies can be set.

With fixed frequency control it is possible to realize different pressure stages with one tool.

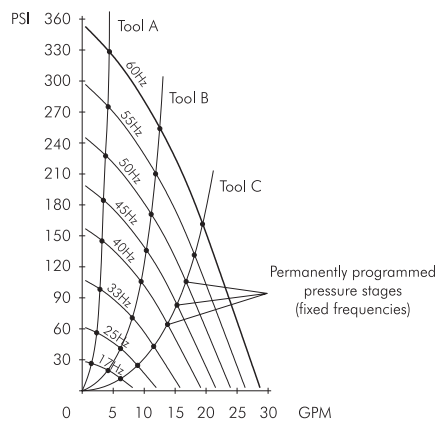
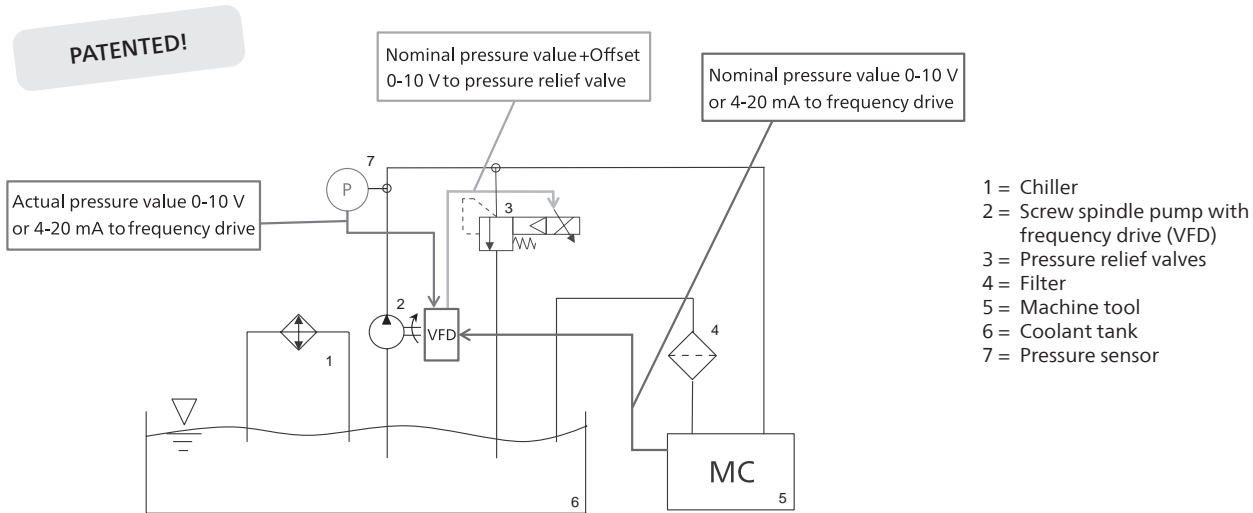

Fig. 6: Fixed frequencies

## Control / Regulation

### Brinkmann Pumps Offset Regulation for High Pressure Pumps

The target pressure is calculated by the VFD based on the working point and is not supplied by the machine tool. The intelligent control of the valves allows for minimizing potential pressure spikes.



### Minimizing pressure peaks during tool change

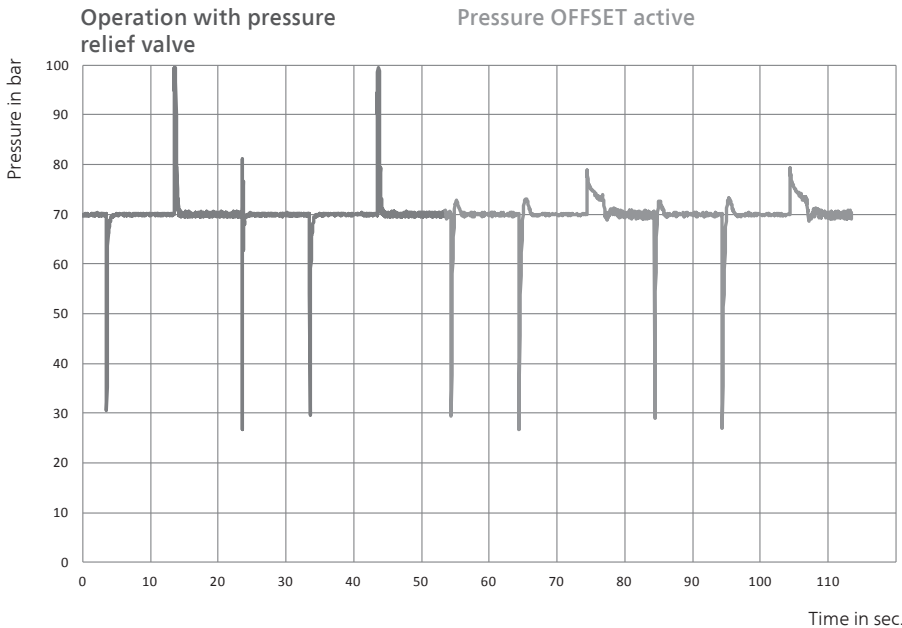

## Control / Regulation

TECHNICAL DATA				
Frequency converter FKO (2.0 – 29.5 HP / 1.5 – 22 kW)				
Function	Specification			
Rated voltage	3 AC 380 V -10 % ... 480 V +10 %			
Rated frequency	50/60 Hz ± 6 %			
Output ranges	... 2.0 HP	3.0 – 5.4 HP	7.4 – 10 HP	15 – 29.5 HP
Housing size	A	B	C	D
Protective system	IP 65			IP 55
EMV approvals acc. to EN61800-3US	C2			
Temperature range	14 °F ... 122 °F			
Overload capability	1.5 times rated output current			
Protective functions	undervoltage, overvoltage, I <sup>2</sup> t-restriction, short circuit, motor temperature, converter temperature, anti-tilt protection			
Output frequency range	according to layout at factory			
Digital inputs	4			
Fixed frequencies	7			
Digital outputs	2			
Analog inputs	2 analog inputs (0/2 – 10 V, 0/4 – 20 mA)			
Analog outputs	0 – 10 V (-Imax = 10 mA) or 0 – 20 mA (burden R = 500 Ω)			
Process control	PID			
Relay outputs	2 x NO contacts 250 V AC 2 A			
USB interface	USB on plug M12 (RS485/RS232)			
Manual control unit (optional)	MMI with cable			
BUS modules (optional)	PROFIBUS DP, CANopen, EtherCAT, PROFINET			
UL approval	yes			

### Dimensions with Brinkmann motor

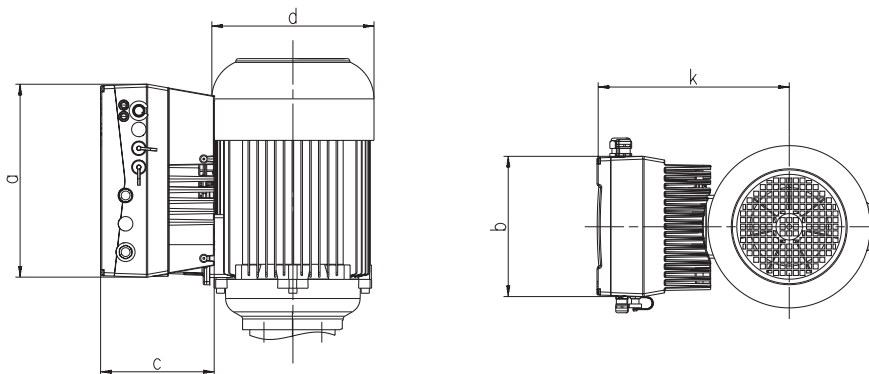

Motor power		housing size	a inch	b inch	c inch	d inch	k inch
kW	HP						
1.1	1.5	A	9.17	6.02	4.72	5.43	7.83
1.3 – 1.7	1.7 – 2.3	A	9.17	6.02	4.72	6.93	8.23
1.9 – 2.6	2.5 – 3.5	B	10.63	7.44	5,51	6.93	8.78
3.0 – 4.0	4.0 – 5.4	B	10.63	7.44	5,51	8.58	9.57
5.0 – 5.5	6.7 – 7.4	C	12.09	8.78	7.13	8.58	11.30
6.0 – 9.0	8.0 – 12.1	C	12.09	8.78	7.13	10.16	12.05
11.0 – 13.0	14.7 – 17.4	D	16.30	11.57	9.17	12.36	15.91