



brainpower your pumps!



螺杆泵 2023

控制, 最优化, 数码化.

完美工业4.0: bplogic水泵控制技术可将BRINKMANN PUMPS的专业技术智能化地整合到机床、水泵、过滤系统和其他部件之间。

bplogic完美适用于既有系统环境-无论客户采用何种变频器。



brainpower your pumps!

bplogic

设备特点

连通性

基本应用

监控

预测性维护

软传感器

高阶应用

详细信息请参考以下:
bplogic.brinkmannpumps.de



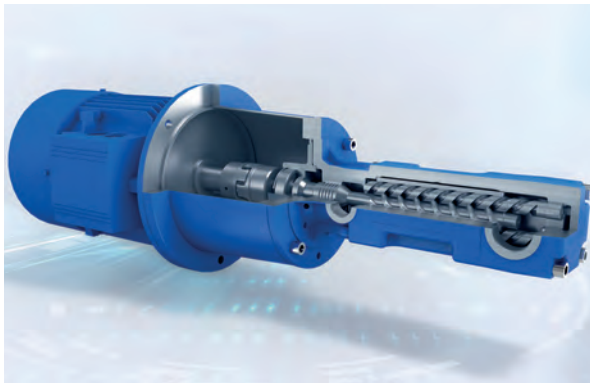

技术信息	
电气	4 – 8
控制/调节	9 – 12
高压螺杆泵的型号和应用	13 – 15
配件	
调压阀	48 – 50
压力表, 吸入保护盖	51
G4 型	51
SAE 法兰	51
完整组装的泵的系统	52 – 56
问询表	57



高压泵	螺杆	50 Hz
高压泵 BFS1 FFS1, 50 Hz	螺杆 高压 2.6 ... 20.1 l/min 10 ... 150 bar	16 – 17
高压泵 BFS2 FFS2, 50 Hz	螺杆 高压 7 ... 47.4 l/min 10 ... 150 bar	18 – 21
高压泵 TFS3 FFS3, 50 Hz	螺杆 高压 16.2 ... 98.5 l/min 10 ... 150 bar	22 – 23
高压泵 TFS4 FFS4, 50 Hz	螺杆 高压 32 ... 194 l/min 10 ... 120 bar	24 – 25
高压泵 TFS5 FFS5, 50 Hz	螺杆 高压 80 ... 412 l/min 10 ... 120 bar	26 – 29
高压泵 TFS6 FFS6, 50 Hz	螺杆 高压 165 ... 725 l/min 10 ... 80 bar	30 – 31



高压泵	螺杆	60 Hz
高压泵 BFS1 FFS1, 60 Hz	螺杆 高压 3.2 ... 24.4 l/min 10 ... 150 bar	32 – 33
高压泵 BFS2 FFS2, 60 Hz	螺杆 高压 10.2 ... 57.6 l/min 10 ... 150 bar	34 – 37
高压泵 TFS3 FFS3, 60 Hz	螺杆 高压 22.8 ... 119.5 l/min 10 ... 150 bar	38 – 39
高压泵 TFS4 FFS4, 60 Hz	螺杆 高压 45 ... 235 l/min 10 ... 120 bar	40 – 41
高压泵 TFS5 FFS5, 60 Hz	螺杆 高压 105 ... 500 l/min 10 ... 120 bar	42 – 45
高压泵 TFS6 FFS6, 60 Hz	螺杆 高压 213 ... 878 l/min 10 ... 80 bar	46 – 47



电气

符合EN 60034-1标准的电机

保护等级	IP55
绝缘等级	F
级数	2
效率	EN 60034-30, IE3 ≥ 0.75 kW

	50 Hz		60 Hz	
	220 V – 240 V Δ 380 V – 415 V Υ	380 V – 415 V Δ	460 V Υ	460 V Δ
低于5.5kW	标准	●	标准	●
大于6kW	–	标准	–	标准

根据DIN EN 60034-1，区域A，持续工作的话，电压公差是± 5 %，频率公差是± 2 %。

特殊电压根据需求提供：

	200 V	200 V 220 V	200 V – 220 V 400 V	380 V	400 V	415 V	440 V	480 V	500 V	575 V	200 V $\Upsilon\Upsilon$ 400 V Υ	230 V $\Upsilon\Upsilon$ 460 V Υ
50 Hz	●	–	–	●	●	●	–	–	●	–	●	–
60 Hz	–	●	●	●	●	–	●	●	–	●	–	●

● 可提供 – 不提供

其他电压请洽询。

针对特殊需求，咨询厂家后可提供标准的可同时在50Hz和60Hz下工作的产品（使用变压器），如3 x 400 V, ± 5 %, 50 – 60 Hz。

6 kW电机

电机以三角方式连接。

如有需要，电机允许以 Υ/Δ 启动。

螺杆泵用 Υ/Δ 启动的话，必须无压力启动。

Υ/Δ 启动，建议安装软启动器。

开关频率

小于3kW的电机：
最多200次/小时

3kW到4kW的电机：
最多40次/小时

5kW到9kW的电机：
最多20次/小时

11kW或以上的电机：
最多15次/小时

如需选择其他启动频率请洽询。

电气

非欧洲标准, Brinkmann 电机



Approved by UL with „UL Recognized Component Mark“ for USA acc. to UL 1004-1 and for Canada acc. to CSA C22.2 No. 100-14 (UL-File E233349)



Brinkmann电机, 最大15kW, 60Hz, 不超过600V, 可提供UL认证标记, 通过特殊设计。



CC311B
Compliance Certification number
CC311B
according to 10 C.F.R. §431
(NEMA PREMIUM EFFICIENCY)

Brinkmann电机, 从1.3kW-13kW, 50Hz可根据要求提供中国节能标签GB18613-2020, 3级。



Brinkmann电机, 从0.86kW-15kW, 60Hz 可根据要求提供 NEMA PREMIUM MG1。

Brinkmann电机, 从1.1kW到6.3kW, 可根据要求提供韩国 KEMCO认证。

Brinkmann电机可选	50 Hz					60 Hz									
	200 V	380 V	400 V	415 V	500 V	200 V 220 V	380 V	400V	440 V	460 V	230 V 460 V	480 V	230 V 480 V	575 V 600 V	
UL/CSA	-	-	-	-	-	●	●	●	●	●	●	●	●	●	
CEL (Grade 3) 1,3 kW – 13 kW	●	●	●	●	●	-	-	-	-	-	-	-	-	-	
NEMA PREMIUM MG 1 ≥ 0.86 kW	Y 0.86 – 6.3 kW	-	-	-	-	●	●	●	●	●	●	●	●	●	
	Δ 3.45 – 15 kW	-	-	-	-	-	●	●	●	●	-	●	-	●	
	YY/Y 0.86 – 15 kW	-	-	-	-	-	-	○	-	-	●	-	●	-	
KEMCO	Y 1.1 – 6.3 kW	-	-	-	-	-	●	●	●	●	-	●	-	-	
	Δ 1.1 – 6.3 kW	-	-	-	-	●	○	○	○	○	-	○	-	-	
	YY/Y 1.1 – 5.8 kW	-	-	-	-	●	-	●	-	-	-	-	-	-	

● 可提供 - 不提供 ○ 根据需求 其他国家标准可洽询。

非欧洲标准, 标准电机

根据需求。取决于实际电机的等级和规格 (功率/电机效率等级), 泵体和电机可以有不同的组合。配置标准电机的泵的总览可以参考我们的网站。

电流/额定电流

铭牌上的电流 ($I_{catalog}$) 是作为电器部件的尺寸标示。

电机 ≤ 0.12 kW (50 Hz): $I_{max} = I_{catalog}$
 电机 0.17 kW – 0.32 kW: $I_{max} =$ 请参照表格。
 电机 ≥ 0.48 kW: $I_{max} = 1.05 \times I_{catalog}$

功率	I_{max} @400 V, 50 Hz	I_{max} @460 V, 60 Hz
0.17/0.195 kW	$I_{max} = 1.2 \times I_N$	$I_{max} = 1.08 \times I_N$
0.22/0.255 kW	$I_{max} = 1.14 \times I_N$	$I_{max} = 1.08 \times I_N$
0.32/0.365 kW	$I_{max} = 1.24 \times I_N$	$I_{max} = 1.1 \times I_N$

其他电压请洽询。

对于超出的电压范围, 我们只在参数表上提供最高电流值。



电机技术参数 IE3

三相感应电机 2极，热保护等级 F，保护等级 IP55

Brinkmann 电机

	功率 50 Hz / 60 Hz kW	电流 2极 50Hz A		噪音等级 dBA / 50 Hz	电流 2极 60Hz A		噪音等级 dBA / 60 Hz
		Y 380 V – 415 V	Δ 380 V – 415 V		Y 460 V	Δ 460 V	
		IE3					
	B 1.3 / 1.49	2.80 – 2.75	–	63	2.7	–	67
	B 1.5 / 1.75	3.20 – 3.05	–	63	3.1	–	67
	B 1.7 / 1.95	3.60 – 3.60	–	63	3.5	–	67
	B 1.9 / 2.18	3.95 – 3.90	–	63	3.9	–	67
	B 2.2 / 2.55	4.50 – 4.35	–	63	4.4	–	67
	B 2.6 / 2.94	5.35 – 5.20	–	63	5.1	–	67
	B 3.0 / 3.45	6.20 – 6.20	–	63	6.0	–	67
	B 3.3 / 3.8	6.70 – 6.60	–	71	6.4	–	75
	B 4.0 / 4.55	8.30 – 8.35	–	71	7.9	–	75
	B 5.0 / 5.75	10.0 – 9.65	–	71	9.5	–	75
	B 5.5 / 6.3	10.9 – 10.4	–	74	10.4	–	77
	B 6.0 / 6.9	–	11.2 – 10.6	74	–	10.7	77
	B 6.5 / 7.48	–	12.0 – 11.3	74	–	11.5	77
	B 7.5 / 8.6	–	14.3 – 13.4	74	–	13.7	77
	B 9.0 / 10.3	–	16.7 – 15.6	74	–	15.8	78
	B 11.0 / 12.6	–	20.1 – 18.8	75	–	19.5	80
	B 13.0 / 15.0	–	24.2 – 23.5	77	–	23.6	80

标准电机

	功率 50 Hz / 60 Hz kW	电流 2极 50Hz A	噪音等级 dBA / 50 Hz	电流 2极 60Hz A	噪音等级 dBA / 60 Hz	电流 4极 50Hz A	噪音等级 dBA / 50 Hz	电流 4极 60Hz A	噪音等级 dBA / 60 Hz
		Y 400 V		Y 460 V		Y 400 V		Y 460 V	
		IE3							
	0.75 / 0.86	1.56	63	1.63	67	1.75	56	1.72	58
	1.1 / 1.27	2.25	63	2.25	67	2.4	59	2.35	61
	1.5 / 1.75	3.0	68	2.95	72	3.15	59	3.15	61
	2.2 / 2.54	4.2	68	4.2	72	4.4	63	4.35	65
	3.0 / 3.45	5.6	70	5.5	74	5.9	63	5.8	65
	4.0 / 4.55	7.3	72	7.2	76	7.9	61	7.7	65
	5.5 / 6.3	9.9	72	9.8	76	10.5	67	10.5	71
		Δ 400 V		Δ 460 V		Δ 400 V		Δ 460 V	
IE3									
	7.5 / 8.6	13.1	72	13.0	75	14.3	67	14.2	71
	11.0 / 12.6	19.6	75	19.5	80	20.5	68	20.0	72
	15.0 / 17.3	27.0	75	27.0	80	28.5	68	28.0	72
	18.5 / 21.3	32.0	75	32.0	80	35.0	69	34.5	71
	22.0 / 25.3	37.5	76	37.5	>80	41.0	71	41.0	73
	30.0 / 33.5*	53.0	76	52.0	>80	55.0	68	55.0	71
	37.0 / 41.5*	65.0	77	63.0	>80	70.0	68	68.0	70
	45.0 / 51.0*	78.0	77	77.0	>80	80.0	68	81.0	70
	55.0 / 62.0*	95.0	>80	92.0	>80	96.0	69	97.0	70
	75.0 / 84.0	128.0	>80	128.0	>80				
	90.0 / 101.0	152.0	>80	148.0	>80				
	110.0 / 123.0	183.0	>80	179.0	>80				

标准电机噪音等级有 + 3 dBA 的误差。

取决于实际电机的等级和规格（功率/电机效率等级），泵体和电机可以有不同的组合。可以使用其他的电机供应商，根据需求。

* 60Hz的额定功率不同，请参考4极工作的参数表。



电机技术参数 NEMA Premium

三相感应电机 2极, 热保护等级 F, 保护等级 IP55

Brinkmann 电机

	功率 60 Hz kW / HP	电流 2极 60 Hz A		噪音等级 dBA / 60 Hz
		Y 460 V	Δ 460 V	
MG1 12-12	B 1.49 / 2.0	2.7	—	67
	B 1.75 / 2.3	3.1	—	67
	B 1.95 / 2.6	3.5	—	67
	B 2.18 / 2.9	3.9	—	67
	B 2.55 / 3.4	4.4	—	67
	B 2.94 / 3.9	5.1	—	67
	B 3.45 / 4.6	6.0	—	67
	B 3.8 / 5.1	6.4	—	75
	B 4.55 / 6.1	7.9	—	75
	B 5.75 / 7.7	9.5	—	75
	B 6.3 / 8.4	10.4	—	77
	B 6.9 / 9.2	—	10.7	77
	B 7.48 / 10.0	—	11.5	77
	B 8.6 / 11.5	—	13.7	77
	B 10.3 / 13.8	—	15.8	78
B 12.6 / 16.9	—	19.5	80	
B 15.0 / 20.1	—	23.6	80	

标准电机

	功率 60 Hz kW / HP	电流 2极 60 Hz A	噪音等级 dBA / 60 Hz	电流 4极 60 Hz A	噪音等级 dBA / 60 Hz
		Y 460 V		Y 460 V	
MG1 12-12	0.75 / 1.0	1.45	67	1.59	58
	1.1 / 1.5	1.98	67	2.15	61
	1.5 / 2.0	2.6	72	2.85	61
	2.2 / 3.0	3.65	72	3.8	65
	3.0 / 4.0	4.9	74	5.1	65
	3.7 / 5.0	6.0	76	6.5	65
	5.5 / 7.5	8.6	76	9.3	71
		Δ 460 V		Δ 460 V	
MG1 12-12	7.5 / 10.0	11.5	75	12.4	71
	11.0 / 15.0	17.2	80	18.0	72
	15.0 / 20.0	24.0	80	25.0	72
	18.5 / 25.0	28.0	80	30.5	71
	22.0 / 30.0	34.0	81	36.5	73
	30.0 / 40.0	47.0	81	48.0	71
	37.0 / 50.0	57.0	82	58.0	70
	45.0 / 60.0	69.0	>82	71.0	70
	55.0 / 75.0	83.0	>82	84.0	70
	75.0 / 100.0	112.0	>82	116.0	82
	90.0 / 125.0	132.0	>82	136.0	82
110.0 / 150.0	160.0	>82	168.0	82	

标准电机噪音等级有 + 3 dBA 的误差。

特殊电压和曲线请咨询。取决于实际电机的等级和规格 (功率/电机效率等级), 泵体和电机可以有不同的组合。可以使用其他的电机供应商, 根据需求。

电气

电路

标准电压变换 Υ / Δ

如 220 – 240 V / 380 – 415 V, 50 Hz

Δ (三角连接)

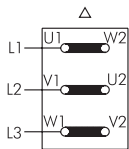

Υ (星型连接)

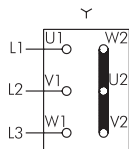

电压转换 1 : 2 $\Upsilon \Upsilon / \Upsilon$

例如 230 V / 460 V, 60 Hz

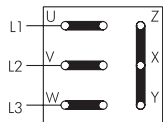

$\Upsilon \Upsilon$
低电压

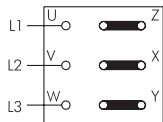

Υ
高电压

安装

Brinkmann 螺杆泵带接口

低于5.5kW 的电机可提供HAN 10针接头，6kW 和 13kW 的电机可提供HAN 模块化接头。

安装海拔和冷却液温度

在此列明的功率 (P_N) 和电机的运行值是符合EN 60034-1标准，操作模式S1 (连接工作模式)，50Hz额定电压，最高外界空气温度(KT)40°C，海拔高度1000m时适用的。这些电机也可以在外界空气温度40°C至60°C之间，或安装海拔超过1000m时使用。如遇此情况，电机功率会如以下图表减小，应选择适当加大规格的电机，或更高的防热等级。然而，随着海拔高度的增加，外界空气温度会根据以下仿真表格减小。因此对此也有相应的与样本列明参数相悖的情况。

安装海拔 / m	防热等级F下的外界冷空气温度 / °C
0 up to 1000	40
1000 up to 2000	30
2000 up to 3000	19
3000 up to 4000	9

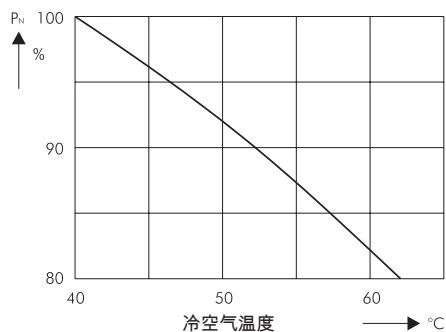
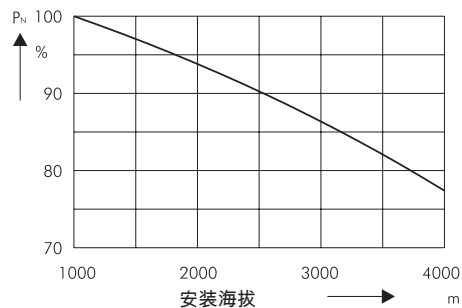

控制/调节

冷却泵的能源消耗主要受泵的效率，电机效率和泵根据系统工作点的选型所影响。

在不同的技术讲座上，我们提供以下支持：

- 泵的选型
- 变频器使用的详细信息
- 展示如何通过泵的控制来节能
- 指导您如何在现有的应用和系统上进行改造

更多信息，请随时联系我们



调节

调节是表示一个物理值，例如压力始终被感应，并与设定值比较。如果偏离，调节设备（此处为PI控制器）可以优化调节。

如果带调节，会检查所需的状态是否达到。这个进程允许达到预定的工作压力，同时调节泵的流量到所需的消耗。



图1：控制图

高压泵的转速控制

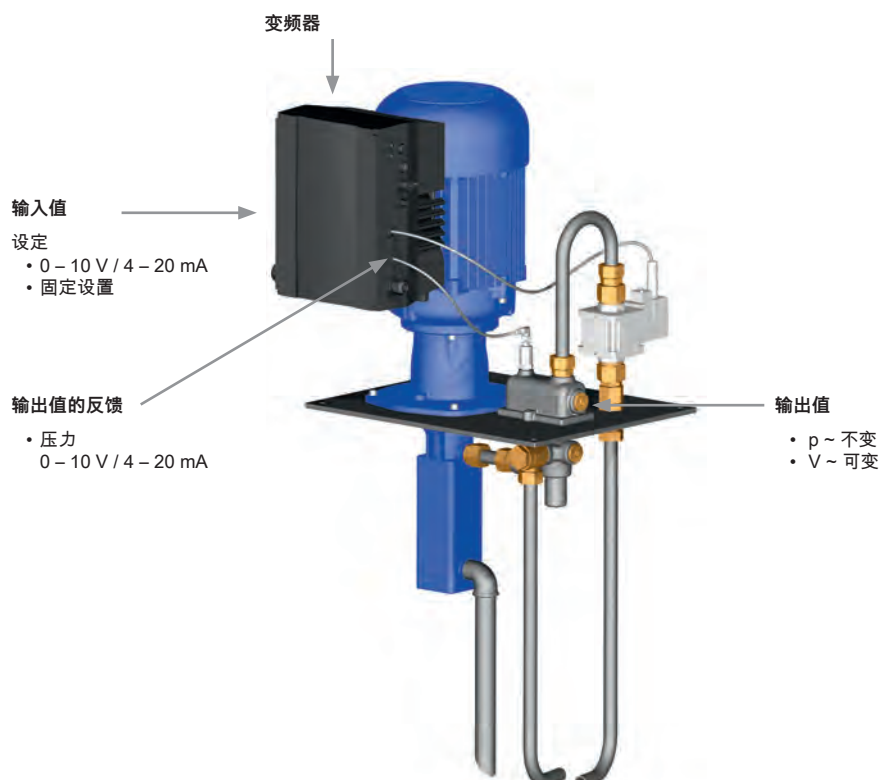

图2：螺杆泵带变频器的在两种消耗下的节能

工作点	调压阀	变频器	注
A	关闭	没有	设计工作点
B	打开	没有	通过调压阀，能量损失
B	关闭	有	最大节能 80% (如压力控制)

螺杆泵带变频器的曲线图

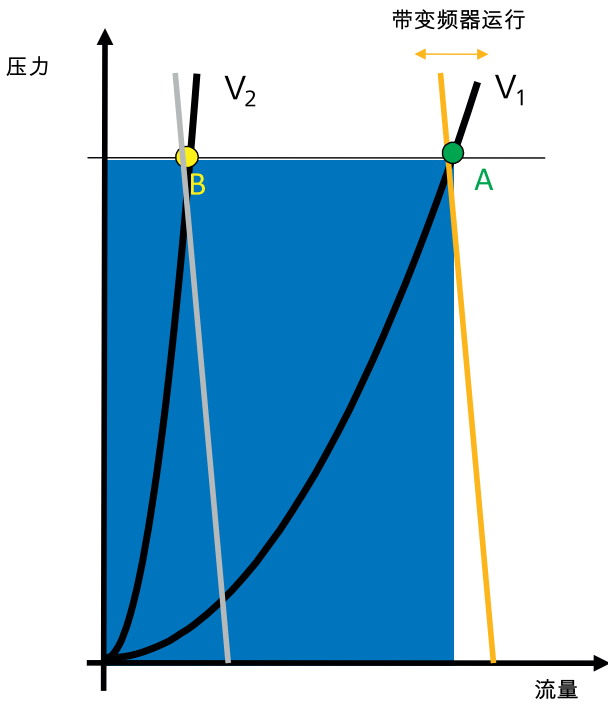

图3：BFS130/150的实例，油 20 mm²/s

Brinkmann Pumps用于高压泵的补偿控制

目标压力值由变频器计算，基于工作点，不由机床提供。阀的智能控制，可以允许最小化压力冲高。

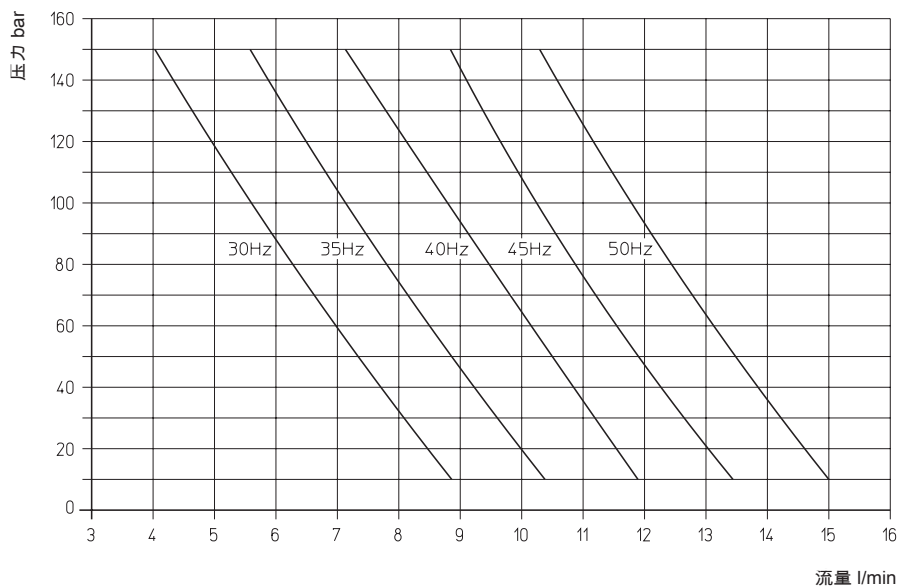
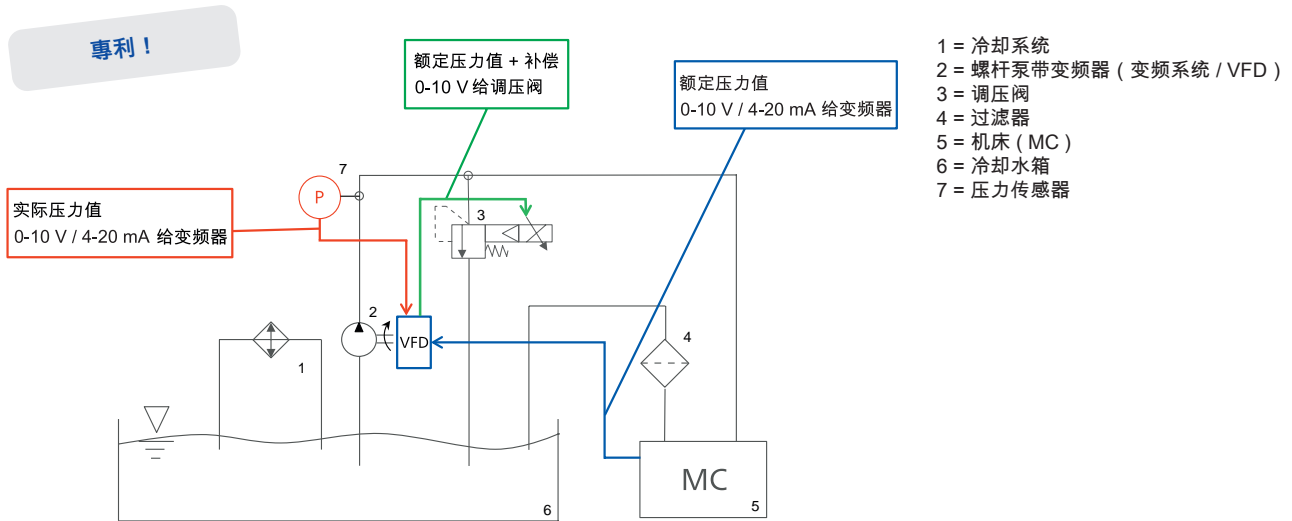

减少换刀时的压力峰值

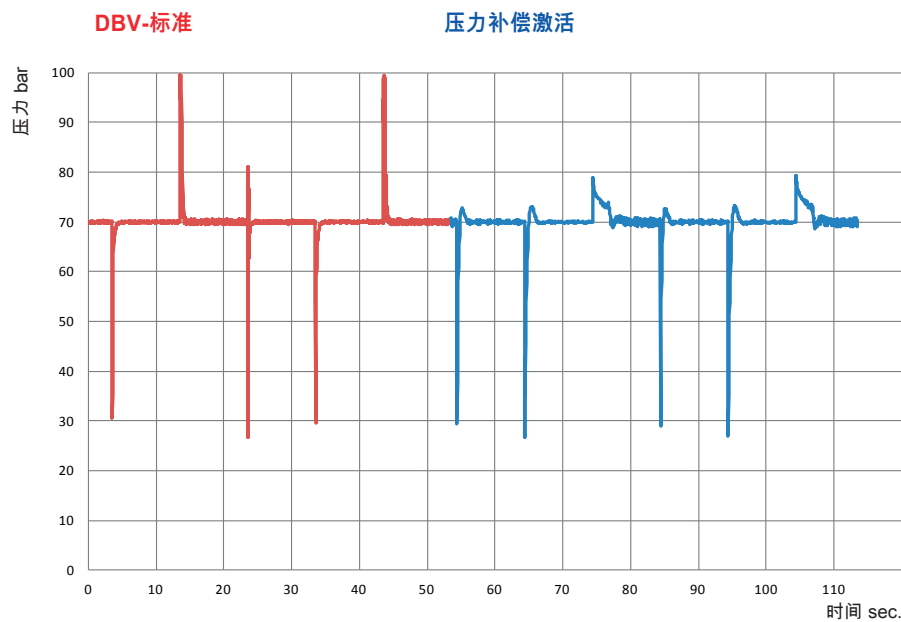

控制/调节

技术参数 变频器 FKO (1.5 – 22 kW)

功能	规格
额定电压	3 AC 380 V -10 % ... 480 V +10 %
额定频率	50/60 Hz ± 6 %
输出范围	... 1.5 kW 2.2 – 4 kW 5.5 – 7.5 kW 11 – 22 kW
外壳尺寸	A B C D
防护等级	IP 65 IP 55
EMV 标准, 根据 EN61800-3US	C2
温度范围	-10 °C ... +50 °C
过载能力	额定输出电流的1.5倍
保护功能	电压不足, 电压过高, I ² t-限制, 短路, 电机温度, 变频器温度, 转子锁死
输出频率范围	根据工厂规划
数字信号输入	4
固定频率	7
数字信号输出	2
模拟信号输入	2 模拟信号输入 (0/2 – 10 V, 0/4 – 20 mA)
模拟信号输出	0 – 10 V (-I最大 = 10mA) 或者 0 – 20 mA (电阻 R = 500Ω)
过程控制	PID
继电器输出	2 x NO 接触 250V AC 2A
USB 接口	USB 接头 M12 (RS485/RS232)
手动控制单元 (可选)	MMI带线
总线模式 (可选)	PROFIBUS DP, CANopen, EtherCAT, PROFINET
UL标准	yes

Brinkmann电机尺寸

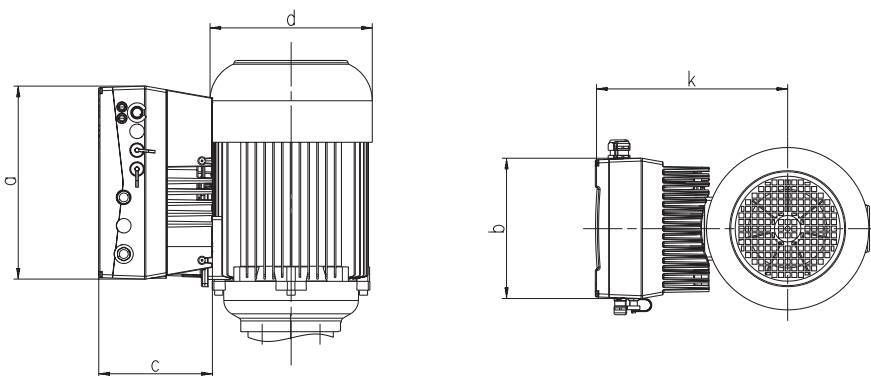

电机功率 kW	外壳尺寸	a mm	b mm	c mm	d mm	k mm
1.1	A	233	153	120	138	199
1.3 – 1.7	A	233	153	120	176	209
1.9 – 2.6	B	270	189	140	176	223
3.0 – 4.0	B	270	189	140	218	243
5.0 – 5.5	C	307	223	181	218	287
6.0 – 9.0	C	307	223	181	258	306
11.0 – 13.0	D	414	294	233	314	404

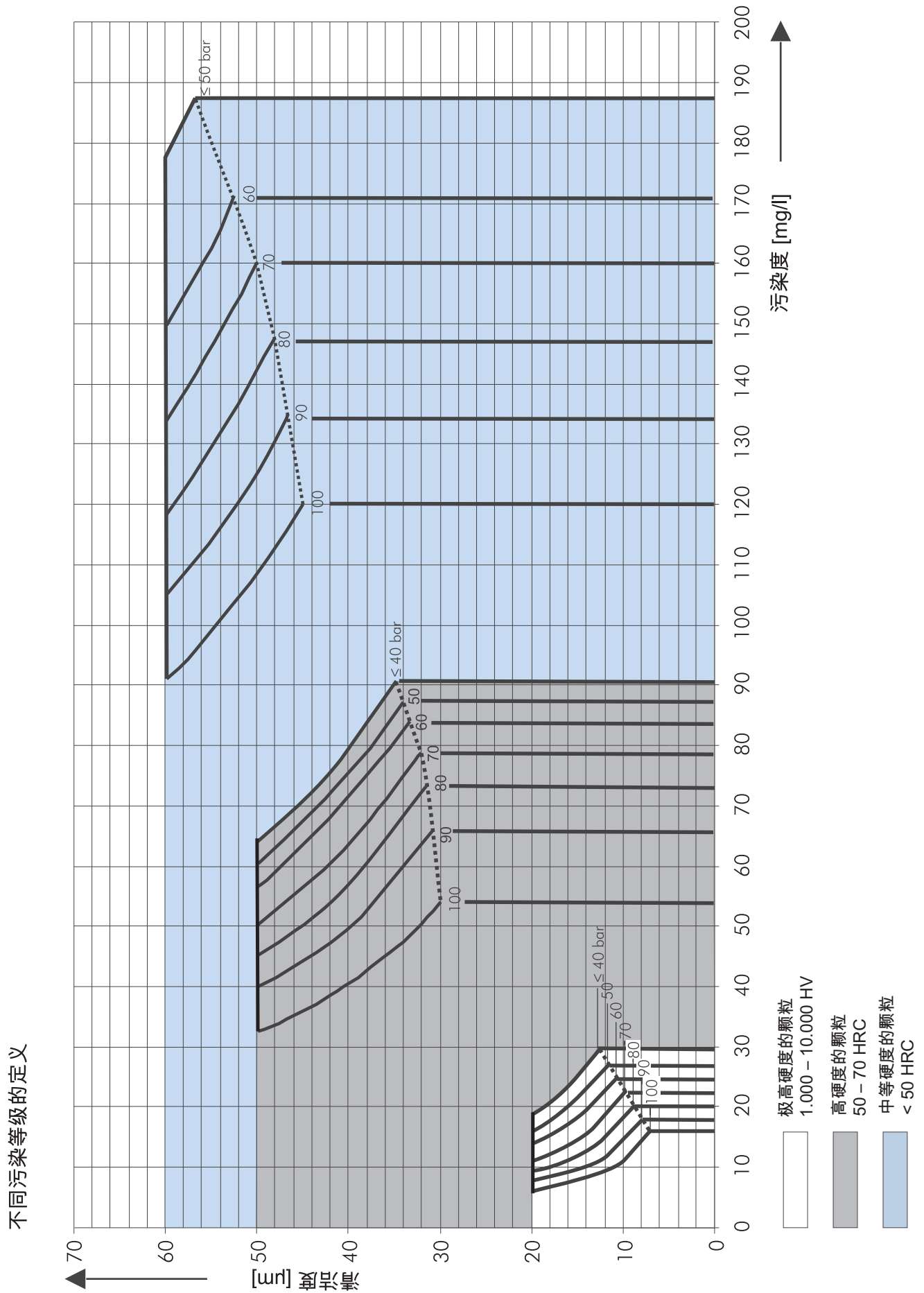

高压螺杆泵模型和应用

带碳化硅螺杆外壳

带碳化硅螺杆外壳和高耐磨材质螺杆的高压泵能达到绝对的高压。

H型：压力出口位于安装板之上；易于进行管路连接。

Brinkmann 高压螺杆泵的设计是针对抽送经过过滤的润滑性流体，如冷却油和水基冷却液。
高压螺杆泵不适合干运转。

应用

介质类型

油
冷却/切削油
冷却液

黏度

1...45 mm²/s (45 cSt)
超过 45 mm²/s 请洽询

工作温度

最高 60 °C *
* 超过 60 °C 请洽询

最大空气含量

3-5 vol. %

推荐过滤等级

一般加工 (车, 铣, 钻) < 50 μm
研磨和铝件加工 (CBN等) < 20 μm

更多信息请参考第13页。

结构材料

压力和吸入端壳体
螺杆外壳

铸铁
碳化硅一片式，
高耐磨和精加工
硬化工具钢，
特殊加工合金；
高耐磨和精加工。
Viton

螺杆

密封

标准设计	型号索引	浸入式						直连式，可直接安装 – 卧式或立式 带机械密封；吸入端正压可达 7 bar					
		BFS1	BFS2	TFS3	TFS4	TFS5	TFS6	FFS1	FFS2	FFS3	FFS4	FFS5	FFS6
迷宫式密封周围带高耐磨碳化硅衬套以及主螺杆带涂层	-KBT5	○	○	○	●	●	–	○	○	○	●	●	–
迷宫式密封周围带高耐磨碳化硅衬套，主螺杆和副螺杆带特殊涂层	-KBT5N	○	○	○	○	○	●	○	○	○	○	○	●
主螺杆和副螺杆带特殊涂层	-T5N	○	○	○	–	–	–	○	○	○	–	–	–
通过吸入端盖的径向滑套进行轴向补偿	-A	○	○	●	●	●	●	○	○	●	●	●	●
直连式安装 – 立式 机械密封和内置的渗漏回流； 吸入正压可达 7 bar	-G	○	○	○	○	○	●	●	●	●	●	●	●
吸入正压为 7-20 bar (带泄漏口: 更多信息, 请参考单独的螺杆泵样本, 第51页。)	-G4	○	○	○	○	–	–	○	○	○	○	–	–
黏度 > 45 mm ² /s		○	○	○	○	○	○	○	○	○	○	○	○

选型号：垂直安装的直连式（无脚安装座）：
BFS1...2 / 压力-G / TFS3...6 / 压力-G e.g. TFS376/40-G

选型号：水平或垂直安装的直连式（带脚安装座）：
FFS1...6 / 压力 e.g. FFS260/40

工作压力120 bar 及以上的高压泵需使用-KBT5NA 形式 (P, P2)。

H型	型号索引	浸入式 最大120bar		
		BFS1-H	BFS2-H	TFS3-H
迷宫式密封周围带高耐磨碳化硅衬套以及主螺杆带涂层	-KBT5	○	○	○
迷宫式密封周围带高耐磨碳化硅衬套，主螺杆和副螺杆带特殊涂层	-KBT5N	○	○	○
主螺杆和副螺杆带特殊涂层	-T5N	○	○	○
通过吸入端盖的径向滑套进行轴向补偿	-A	○	○	●
直连式安装 – 立式 机械密封和内置的渗漏回流； 吸入正压可达 7 bar	-G	□	□	□
黏度 > 45 mm ² /s		○	○	○

○ 需额外费用 ● 标准 □ 根据需求 – 不提供

出口压力越高，泵的功率消耗也随之增加。取决于安装情况，压力超过目标设计压力是有可能发生的。电机必须正确选型，确保最大压力，而不发生过载。表上的泵/电机组合是标准应用（泵+泄压阀）。个别情况下，特殊的泵/电机组合需洽询。

带铸铁螺杆外壳

带铸铁螺杆外壳和高耐磨材质螺杆的高压泵可保证压力最高达80 bar。
Brinkmann 高压螺杆泵的设计是针对抽送经过滤的润滑性流体，如冷却油和水基冷却液。
高压螺杆泵不适合干运转。

应用

介质类型
油
冷却/切削油
冷却液

黏度
1...45 mm²/s (45 cSt)
超过 45 mm²/s 请洽询

工作温度
最高 60 °C *
* 超过 60 °C 请洽询

最大空气含量
3-5 vol. %

推荐过滤等级
一般加工 (车, 铣, 钻) < 50 μm

加工硬度不高的工件
(不适合磨削应用)。
更多信息请参考第13页。

结构材料

压力和吸入端壳体
铸铁
螺杆外壳
铸铁, 硬化处理
硬化工具钢,
特殊加工合金;
高耐磨和精加工。

密封
Viton

类型	型号索引	浸入式	
		BFG2	FFG2
直连式安装 – 立式 机械密封和内置的渗漏回流; 吸入正压可达 7 bar	-G	○	●
黏度 > 45 mm ² /s		○	○
4极电机	-4	○	○

○ 需额外费用 ● 标准

带铸铁外壳的螺杆泵与碳化硅外壳的螺杆泵，尺寸一致。
带铸铁外壳的螺杆泵比带碳化硅外壳的螺杆泵，流量小10%，请见后面内容。

最大工作压力是80 bar。

BFS1, FFS1

50 Hz

螺杆

最大压力	2 极电机 转速 2900 RPM							4 极电机 转速 1450 RPM					
	流量		功率消耗		电机 沉水形式	电机 脚安装形式	重量	流量		功率消耗		电机	重量
	1 mm ² /s	20 mm ² /s	1 mm ² /s	20 mm ² /s				1 mm ² /s	20 mm ² /s	1 mm ² /s	20 mm ² /s		
型号 / bar	l/min	l/min	kW	kW	kW	kW	kg	l/min	l/min	kW	kW	kW	kg
BFS130/	Q _{Th} ¹⁾ 15.6		-	-	-	-	-	Q _{Th} ¹⁾ 7.8		-	-	-	-
10	14	15	0.5	0.5	B 1.3	0.75	39	6.2	7.2	0.2	0.2	0.75	30
20	13.1	14.6	0.8	0.8	B 1.3	1.1	39	5.3	6.8	0.4	0.4	0.75	30
30	12.1	14.2	1.0	1.0	B 1.3	1.5	39	4.3	6.4	0.5	0.5	0.75	30
40	11.2	13.9	1.3	1.3	B 1.5	1.5	39	3.4	6.1	0.6	0.7	0.75	30
50	10.3	13.5	1.5	1.6	B 1.7	2.2	40	-	5.7	-	0.8	1.1	32
60	9.5	13.2	1.8	1.9	B 2.2	2.2	44	-	5.4	-	0.9	1.1	32
70	8.7	12.8	2.1	2.1	B 2.6	3.0	45	-	5	-	1.1	1.5	34
80	7.9	12.5	2.3	2.4	B 2.6	3.0	45	-	4.7	-	1.2	1.5	34
90	7.1	12.1	2.6	2.7	B 3.0	3.0	57	-	4.3	-	1.3	1.5	34
100	6.4	11.8	2.8	2.9	B 3.3	4.0	57	-	4	-	1.5	2.2	45
110	5.7	11.5	3.1	3.2	B 3.3	4.0	57	-	-	-	-	-	-
120	5	11.2	3.4	3.5	B 4.0	4.0	58	-	-	-	-	-	-
130	-	10.9	-	3.8	B 4.0	4.0	58	-	-	-	-	-	-
140	-	10.6	-	4.0	B 5.0	5.5	63	-	-	-	-	-	-
150	-	10.3	-	4.3	B 5.0	5.5	63	-	-	-	-	-	-
BFS140/	Q _{Th} ¹⁾ 20.9		-	-	-	-	-	Q _{Th} ¹⁾ 10.5		-	-	-	-
10	18.8	20.1	0.6	0.7	B 1.3	1.1	39	8.4	9.6	0.3	0.3	0.75	30
20	17.5	19.5	0.9	1.0	B 1.3	1.5	39	7.1	9.1	0.4	0.5	0.75	30
30	16.3	19	1.3	1.4	B 1.5	1.5	39	5.8	8.6	0.6	0.7	1.1	32
40	15.1	18.5	1.6	1.7	B 1.9	2.2	44	4.7	8.1	0.8	0.9	1.1	32
50	14	18	2.0	2.1	B 2.2	3.0	44	3.6	7.6	1.0	1.1	1.5	34
60	13	17.6	2.3	2.5	B 2.6	3.0	45	2.6	7.1	1.1	1.3	1.5	34
70	12	17.1	2.7	2.8	B 3.3	3.0	57	-	6.6	-	1.4	2.2	45
80	11.1	16.6	3.0	3.2	B 3.3	4.0	57	-	6.2	-	1.6	2.2	45
90	10.3	16.2	3.4	3.5	B 4.0	4.0	58	-	5.7	-	1.8	2.2	45
100	9.5	15.7	3.7	3.9	B 4.0	5.5	60	-	5.3	-	2.0	2.2	45
110	8.3	15.3	4.1	4.3	B 5.0	5.5	63	-	-	-	-	-	-
120	7.3	14.8	4.4	4.6	B 5.0	5.5	63	-	-	-	-	-	-
130	6.3	14.4	4.8	5.0	B 5.5	5.5	63	-	-	-	-	-	-
140	-	14	-	5.3	B 5.5	5.5	63	-	-	-	-	-	-
150	-	13.6	-	5.7	B 6.0	7.5	87	-	-	-	-	-	-

1) Q_{Th}: 理论流量

更高压力(最大 200 bar) 请洽询。

黏度 > 20 mm²/s 更大功率消耗。

特性和尺寸

BFS1, FFS1

50 Hz

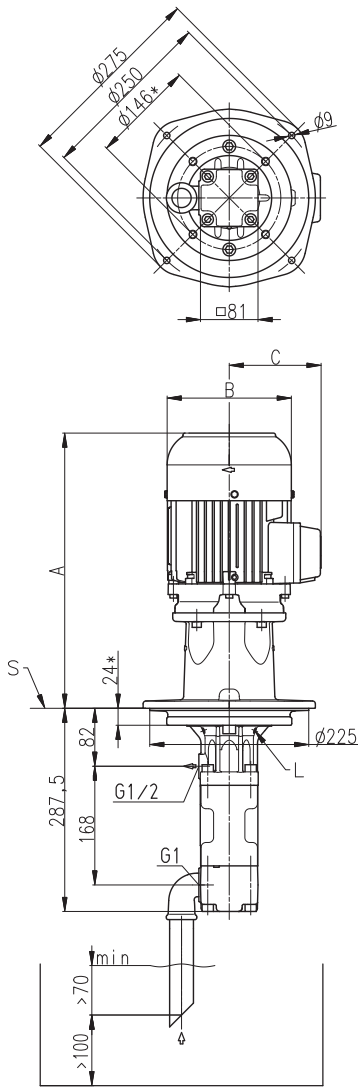

安装孔形式

BFS1 / BFS2

TFS1 / TFS2

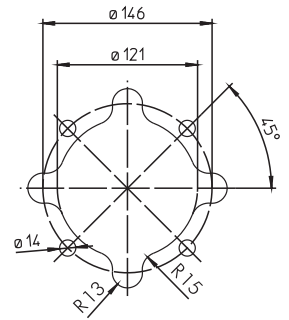
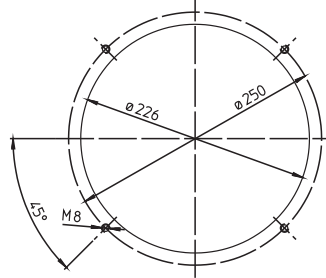

所有角落
必须排除!
根据
ISO 2768-m

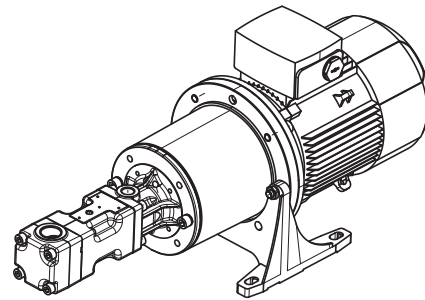

*) 4 极标准电机的尺寸图
请洽询
L = 泄漏孔
S = 安装板, 请参考
安装孔的位置

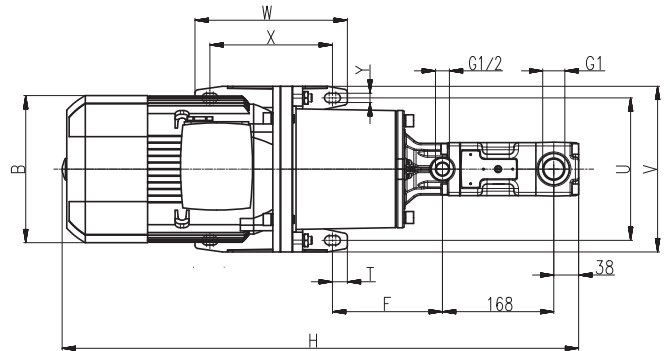
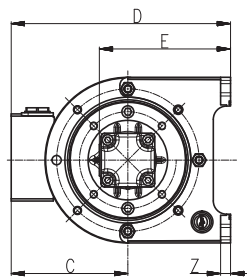

功率 2 极 kW	A mm	B mm	C mm
B 1.3 / 1.5	415	176	130
B 1.7	441	176	130
B 1.9 / 2.2 / 2.6	474	176	130
B 3.0 / 3.3 / 4.0	513	218	150
B 5.0 / 5.5	543	218	150
B 6.0	584	258	193

功率 2 极 kW	功率 4 极 kW	B mm	C mm	D mm	E mm	F mm	H mm	T mm	U mm	V mm	W mm	X mm	Y mm	Z mm
0.75	-	159	121	233	155	138	676	15	180	210	90	60	11	12
-	0.75	159	121	233	155	138	751	15	180	210	90	60	11	12
1.1	-	159	121	233	155	138	711	15	180	210	90	60	11	12
1.5	1.1 / 1.5	178	126	238	155	138	721	15	180	210	90	60	11	12
2.2	-	178	126	238	155	138	761	15	180	210	90	60	11	12
3.0	2.2	198	166	321	198	166	821	22.5	215	250	230	185	14	15
4.0	-	222	177	332	198	166	805	22.5	215	250	230	185	14	15
5.5	-	262	202	387	228	171	857	22.5	265	300	270	225	14	18
7.5	-	262	202	387	228	171	907	22.5	265	300	270	225	14	18

BFS2, FFS2

50 Hz

螺杆

2 极电机 转速 2900 RPM									4 极电机 转速 1450 RPM				
最大 压力	流量		功率消耗		电机 沉水形式	电机 脚安装形 式	重量	流量		功率消耗		电机	重量
	1 mm ² /s	20 mm ² /s	1 mm ² /s	20 mm ² /s				1 mm ² /s	20 mm ² /s	1 mm ² /s	20 mm ² /s		
型号 / bar	l/min	l/min	kW	kW	kW	kW	kg	l/min	l/min	kW	kW	kW	kg
BFS232/	Q _{Th} ¹⁾ 26.1		-	-	-	-	-	Q _{Th} ¹⁾ 13.1		-	-	-	-
10	24.3	25.4	0.7	0.8	B 1.3	1.1	40	11.2	12.4	0.3	0.5	0.75	31
20	23.6	25.2	1.1	1.3	B 1.5	1.5	40	10.6	12.1	0.6	0.7	1.1	33
30	23	24.9	1.5	1.7	B 1.9	2.2	45	10	11.9	0.8	0.9	1.1	33
40	22.4	24.6	2.0	2.2	B 2.6	3.0	46	9.4	11.6	1.0	1.2	1.5	35
50	21.8	24.4	2.4	2.7	B 3.0	3.0	58	8.8	11.3	1.2	1.4	1.5	35
60	21.2	24.1	2.8	3.1	B 3.3	4.0	58	8.2	11.1	1.4	1.6	2.2	46
70	20.6	23.9	3.3	3.6	B 4.0	4.0	59	7.6	10.8	1.7	1.9	2.2	46
80	20	23.6	3.7	4.0	B 5.0	5.5	64	7	10.6	1.9	2.1	2.2	46
90	19.5	23.3	4.1	4.5	B 5.0	5.5	64	6.4	10.3	2.1	2.3	3.0	46
100	18.9	23.1	4.6	4.9	B 5.5	5.5	64	5.8	10	2.3	2.5	3.0	46
110	18.4	22.9	5.0	5.4	B 5.5	7.5	75	-	-	-	-	-	-
120	17.8	22.6	5.5	5.8	B 7.5	7.5	94	-	-	-	-	-	-
130	17.3	22.4	5.9	6.3	B 7.5	7.5	94	-	-	-	-	-	-
140	16.7	22.1	6.3	6.7	B 7.5	7.5	94	-	-	-	-	-	-
150	16.2	21.9	6.8	7.2	B 7.5	7.5	94	-	-	-	-	-	-
BFS238/	Q _{Th} ¹⁾ 31		-	-	-	-	-	Q _{Th} ¹⁾ 15.5		-	-	-	-
10	28.8	30.1	0.7	0.7	B 1.3	1.1	40	13.3	14.6	0.4	0.4	0.75	31
20	28.1	29.8	1.3	1.3	B 1.5	1.5	40	12.6	14.3	0.6	0.6	0.75	31
30	27.4	29.5	1.8	1.8	B 2.2	2.2	45	11.9	14	0.9	0.9	1.1	33
40	26.7	29.2	2.3	2.4	B 2.6	3.0	46	11.2	13.7	1.2	1.2	1.5	35
50	26	28.9	2.8	2.9	B 3.3	4.0	58	10.5	13.4	1.4	1.5	2.2	46
60	25.3	28.7	3.3	3.5	B 4.0	4.0	59	9.8	13.2	1.7	1.8	2.2	46
70	24.6	28.4	3.8	4.0	B 5.0	5.5	64	9.1	12.9	1.9	2.0	2.2	46
80	23.9	28.1	4.4	4.5	B 5.0	5.5	64	8.4	12.6	2.2	2.3	3.0	46
90	23.2	27.8	4.9	5.1	B 5.5	5.5	64	7.7	12.3	2.5	2.6	3.0	46
100	22.5	27.6	5.4	5.6	B 6.0	7.5	87	7	12.1	2.7	2.9	3.0	46
110	21.9	27.3	5.9	6.2	B 6.5	7.5	87	-	-	-	-	-	-
120	21.2	27	6.4	6.8	B 7.5	7.5	94	-	-	-	-	-	-
130	20.6	26.7	6.9	7.3	B 9.0	11.0	100	-	-	-	-	-	-
140	19.9	26.5	7.5	7.9	B 9.0	11.0	100	-	-	-	-	-	-
150	19.3	26.2	8.0	8.4	B 9.0	11.0	100	-	-	-	-	-	-

¹⁾ Q_{Th} : 理论压力

更高压力(最大 200 bar) 请洽询。

黏度 > 20 mm²/s 更大功率消耗。

特性和尺寸

BFS2, FFS2

50 Hz

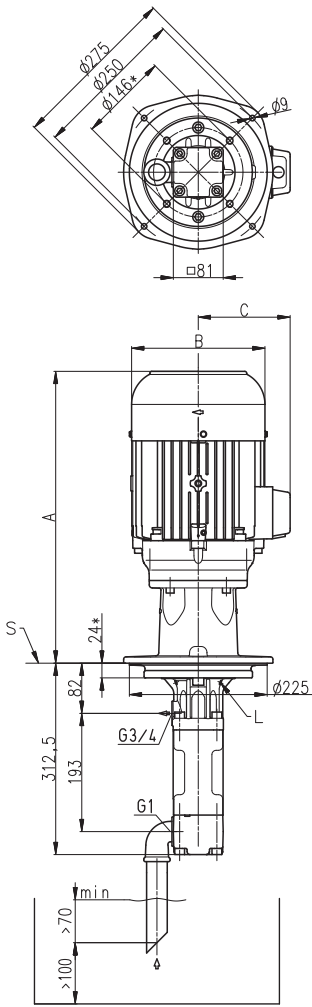

*) 4 极标准电机的尺寸图
电机请洽询
L = 泄漏孔
S = 安装板, 请参考
安装孔的位置

安装孔形式

BFS1 / BFS2

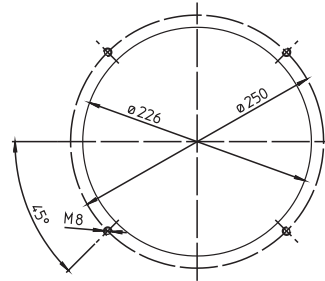

TFS1 / TFS2

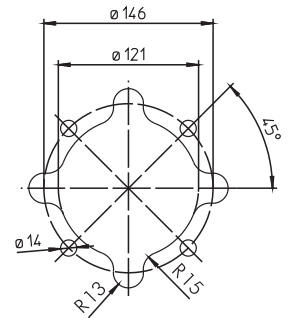

所有角落
必须排除!
根据
ISO 2768-m

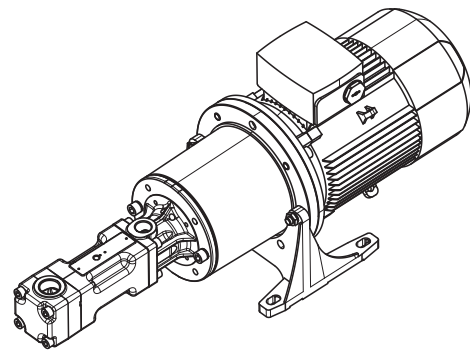

功率 2 极 kW	A mm	B mm	C mm
B 1.3 / 1.5	415	176	130
B 1.9 / 2.2 / 2.6	474	176	130
B 3.0 / 3.3 / 4.0	513	218	150
B 5.0 / 5.5	543	218	150
B 6.0 / 6.5	584	258	193
B 7.5 / 9.0	622	258	193

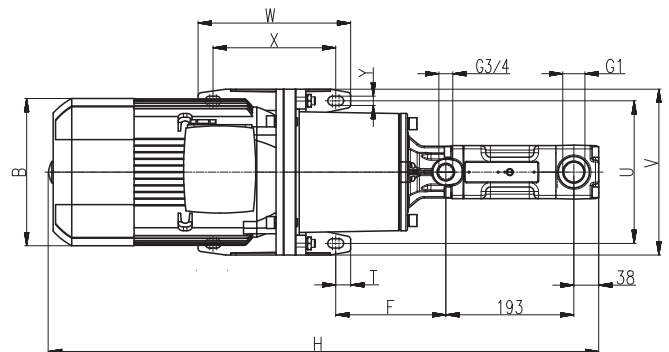
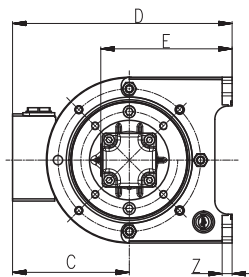

功率 2 极 kW	功率 4 极 kW	B mm	C mm	D mm	E mm	F mm	H mm	T mm	U mm	V mm	W mm	X mm	Y mm	Z mm
-	0.75	159	121	233	155	138	776	15	180	210	90	60	11	12
1.1	-	159	121	233	155	138	736	15	180	210	90	60	11	12
1.5	1.1 / 1.5	178	126	238	155	138	746	15	180	210	90	60	11	12
2.2	-	178	126	238	155	138	786	15	180	210	90	60	11	12
3.0	2.2 / 3.0	198	166	321	198	166	846	22.5	215	250	230	185	14	15
4.0	-	222	177	332	198	166	830	22.5	215	250	230	185	14	15
5.5	-	262	202	387	228	171	882	22.5	265	300	270	225	14	18
7.5	-	262	202	387	228	171	932	22.5	265	300	270	225	14	18
11.0	-	314	237	472	278	210	1051	20	300	350	305	265	18	18

BFS2, FFS2

50 Hz

螺杆

最大压力	2 极电机 转速 2900 RPM							4 极电机 转速 1450 RPM					
	流量		功率消耗		电机沉水形式	电机脚安装形式	重量	流量		功率消耗		电机	重量
	1 mm ² /s	20 mm ² /s	1 mm ² /s	20 mm ² /s				1 mm ² /s	20 mm ² /s	1 mm ² /s	20 mm ² /s		
型号 / bar	l/min	l/min	kW	kW	kW	kW	kg	l/min	l/min	kW	kW	kW	kg
BFS250/	Q _{Th} ¹⁾ 40.8		-	-	-	-	-	Q _{Th} ¹⁾ 20.4		-	-	-	-
10	37.9	39.6	0.9	0.9	B 1.3	1.5	40	17.5	19.2	0.5	0.5	0.75	31
20	37	39.2	1.6	1.6	B 1.9	2.2	45	16.6	18.8	0.8	0.8	1.1	33
30	36	38.9	2.3	2.3	B 2.6	3.0	46	15.6	18.5	1.2	1.2	1.5	35
40	35.1	38.5	3.0	3.1	B 3.3	4.0	58	14.7	18.1	1.5	1.6	2.2	46
50	34.3	38.1	3.6	3.8	B 4.0	4.0	59	13.9	17.7	1.8	1.9	2.2	46
60	33.5	37.7	4.3	4.5	B 5.0	5.5	64	13.1	17.3	2.2	2.3	3.0	46
70	32.7	37.4	5.0	5.2	B 5.5	5.5	64	12.3	17	2.5	2.6	3.0	46
80	31.9	37	5.7	5.9	B 6.5	7.5	87	11.5	16.6	2.9	3.0	4.0	50
90	31.2	36.6	6.4	6.6	B 7.5	7.5	94	10.7	16.2	3.2	3.3	4.0	50
100	30.5	36.2	7.0	7.4	B 9.0	11.0	100	9.9	15.8	3.5	3.7	4.0	50
110	29.2	35.9	7.7	8.1	B 9.0	11.0	100	-	-	-	-	-	-
120	27.9	35.5	8.4	8.8	B 11.0	11.0	122	-	-	-	-	-	-
130	26.6	35.1	9.1	9.5	B 11.0	11.0	122	-	-	-	-	-	-
140	25.4	34.7	9.8	10.2	B 11.0	11.0	122	-	-	-	-	-	-
150	24.1	34.3	10.4	11.0	B 13.0	15.0	122	-	-	-	-	-	-
BFS260/	Q _{Th} ¹⁾ 48.9		-	-	-	-	-	Q _{Th} ¹⁾ 24.5		-	-	-	-
10	45.5	47.4	1.0	1.1	B 1.7	2.2	41	21	23	0.5	0.6	0.75	31
20	44.3	46.9	1.9	2.0	B 2.6	3.0	46	19.9	22.4	0.9	1.0	1.5	35
30	43.2	46.3	2.7	2.9	B 3.3	4.0	58	18.7	21.8	1.4	1.4	2.2	46
40	42	45.7	3.5	3.8	B 5.0	5.5	64	17.6	21.2	1.8	1.9	2.2	46
50	40.9	45.1	4.3	4.6	B 5.0	5.5	64	16.4	20.7	2.2	2.3	3.0	46
60	39.7	44.5	5.1	5.5	B 6.0	7.5	87	15.3	20	2.6	2.8	3.0	46
70	38.5	43.9	5.9	6.4	B 7.5	7.5	94	14.1	19.4	3.0	3.2	4.0	50
80	37.4	43.3	6.8	7.3	B 9.0	11.0	100	12.9	18.8	3.4	3.7	4.0	50
90	36.2	42.6	7.6	8.1	B 9.0	11.0	100	11.8	18.2	3.8	4.1	5.5	82
100	35	42	8.5	9.0	B 11.0	11.0	122	10.6	17.6	4.3	4.5	5.5	82
110	33.4	41.4	9.3	9.9	B 11.0	11.0	122	-	-	-	-	-	-
120	31.8	40.7	10.0	10.8	B 11.0	11.0	122	-	-	-	-	-	-
130	30.1	39.5	10.9	11.7	B 13.0	15.0	122	-	-	-	-	-	-
140	28.5	38.2	11.7	12.5	B 13.0	15.0	122	-	-	-	-	-	-
150	26.9	37	12.5	13.4	-	15.0	103	-	-	-	-	-	-

¹⁾ Q_{Th} : 理论压力

更高压力(最大 200 bar) 请洽询。

黏度 > 20 mm²/s 更大功率消耗。

特性和尺寸

BFS2, FFS2

50 Hz

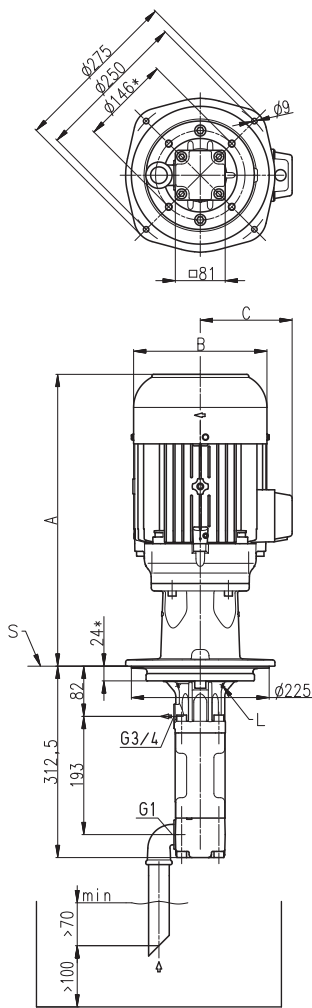

*) 4 极标准电机的尺寸图
电机请洽询
L = 泄漏孔
S = 安装板, 请参考
安装孔的位置

安装孔形式

BFS1 / BFS2

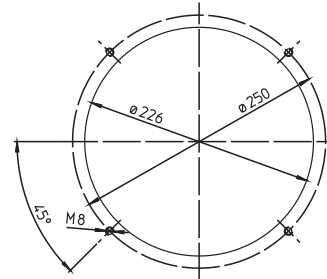

TFS1 / TFS2

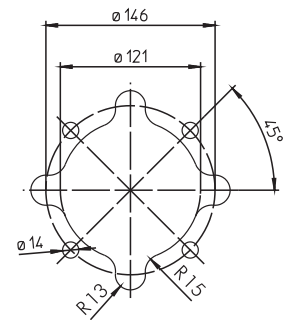

所有角落
必须排除!
根据
ISO 2768-m

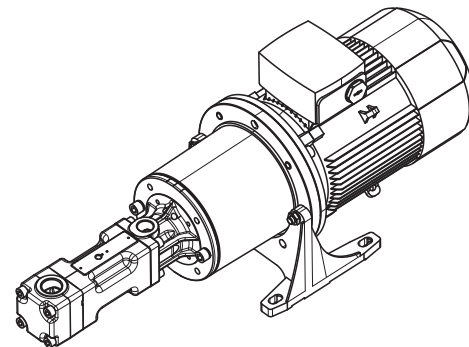

功率 2 极 kW	A mm	B mm	C mm
B 1.3	415	176	130
B 1.7	441	176	130
B 1.9 / 2.6	474	176	130
B 3.3 / 4.0	513	218	150
B 5.0 / 5.5	543	218	150
B 6.0 / 6.5	584	258	193
B 7.5 / 9.0	622	258	193
B 11.0 / 13.0	630	310	240

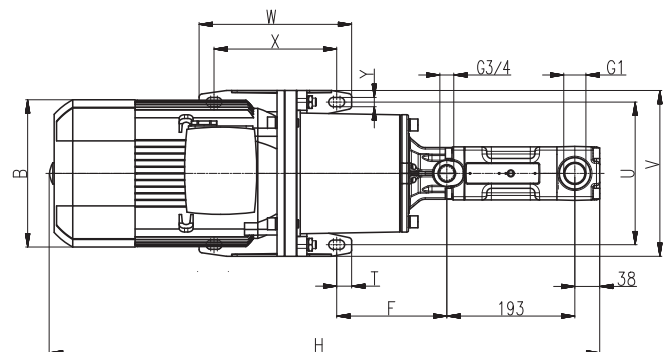
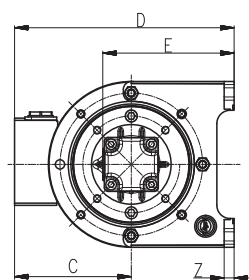

功率 2 极 kW	功率 4 极 kW	B mm	C mm	D mm	E mm	F mm	H mm	T mm	U mm	V mm	W mm	X mm	Y mm	Z mm
-	0.75	159	121	233	155	138	776	15	180	210	90	60	11	12
1.5	1.1 / 1.5	178	126	238	155	138	746	15	180	210	90	60	11	12
2.2	-	178	126	238	155	138	786	15	180	210	90	60	11	12
3.0	2.2 / 3.0	198	166	321	198	166	846	22.5	215	250	230	185	14	15
4.0	4.0	222	177	332	198	166	830	22.5	215	250	230	185	14	15
5.5	-	262	202	387	228	171	882	22.5	265	300	270	225	14	18
7.5	5.5	262	202	387	228	171	932	22.5	265	300	270	225	14	18
11.0 / 15.0	-	314	237	472	278	210	1051	20	300	350	305	265	18	18

TFS3, FFS3

50 Hz

螺杆

2 极电机 转速 2900 RPM							4 极电机 转速 1450 RPM					
最大 压力	流量		功率消耗		电机	重量	流量		功率消耗		电机	重量
	1 mm ² /s	20 mm ² /s	1 mm ² /s	20 mm ² /s			1 mm ² /s	20 mm ² /s	1 mm ² /s	20 mm ² /s		
型号 / bar	l/min	l/min	kW	kW	kW	kg	l/min	l/min	kW	kW	kW	kg
TFS348/	Q _{Th} ¹⁾ 64.1		-	-	-	-	Q _{Th} ¹⁾ 32.1		-	-	-	-
10	60	62.3	1.5	1.6	2.2	47	28	30.3	0.7	0.8	1.1	44
20	58.5	61.5	2.5	2.8	4.0	62	26.5	29.4	1.2	1.3	1.5	47
30	57.1	60.7	3.6	3.9	5.5	72	25	28.6	1.8	1.9	2.2	58
40	55.7	59.9	4.7	5.1	5.5	72	23.6	27.9	2.3	2.4	3.0	58
50	54.4	59.2	5.7	6.2	7.5	86	22.3	27.1	2.8	3.0	4.0	62
60	53.1	58.5	6.8	7.3	11.0	105	21.1	26.5	3.4	3.5	4.0	62
70	51.9	57.9	7.9	8.5	11.0	105	19.8	25.8	3.9	4.1	5.5	93
80	50.7	57.3	8.9	9.6	11.0	105	18.7	25.2	4.4	4.7	5.5	93
90	49.6	56.7	10.0	10.7	15.0	114	17.4	24.6	5.0	5.2	5.5	93
100	48.6	56.1	11.1	11.8	15.0	114	16.2	24.1	5.5	5.8	7.5	93
110	46.7	55.6	12.1	13.0	15.0	114	-	-	-	-	-	-
120	45	55.2	13.2	14.2	15.0	114	-	-	-	-	-	-
130	43.3	54.7	14.3	15.3	18.5	124	-	-	-	-	-	-
140	41.6	54.4	15.3	16.4	18.5	124	-	-	-	-	-	-
150	40	54	16.4	17.6	18.5	124	-	-	-	-	-	-
TFS364/	Q _{Th} ¹⁾ 85.5		-	-	-	-	Q _{Th} ¹⁾ 42.8		-	-	-	-
10	79.9	83	1.8	2.0	3.0	54	37.1	40.3	0.9	0.9	1.5	47
20	78.1	82	3.3	3.5	5.5	72	35.3	39.2	1.6	1.7	2.2	58
30	76.3	81	4.7	5.0	7.5	86	33.6	38.3	2.3	2.4	3.0	58
40	74.6	80.1	6.1	6.5	7.5	86	31.9	37.4	3.0	3.2	4.0	62
50	73	79.2	7.5	8.0	11.0	105	30.2	36.5	3.7	3.9	5.5	93
60	71.4	78.4	9.0	9.5	11.0	105	28.7	35.7	4.4	4.7	5.5	93
70	69.9	77.6	10.4	10.9	15.0	114	27.1	34.9	5.1	5.4	7.5	93
80	68.4	76.9	11.8	12.4	15.0	114	25.6	34.1	5.9	6.1	7.5	93
90	66.9	76.1	13.2	13.9	15.0	114	24	33.4	6.6	6.9	7.5	93
100	65.5	75.5	14.7	15.4	18.5	124	22.4	32.7	7.3	7.6	11.0	113
110	63.2	74.8	16.1	16.9	18.5	124	-	-	-	-	-	-
120	61	74.3	17.5	18.4	22.0	152	-	-	-	-	-	-
130	58.8	72.7	18.9	19.9	22.0	152	-	-	-	-	-	-
140	56.6	71.3	20.4	21.4	22.0	152	-	-	-	-	-	-
150	54.5	69.8	21.8	22.8	30.0	206	-	-	-	-	-	-
TFS376/	Q _{Th} ¹⁾ 101.5		-	-	-	-	Q _{Th} ¹⁾ 50.8		-	-	-	-
10	95.2	98.5	2.1	2.4	4.0	62	44.5	47.8	1.0	1.2	2.2	58
20	93.1	97.3	3.8	4.2	5.5	72	42.3	46.6	1.8	2.1	3.0	58
30	91	96.2	5.5	6.0	7.5	86	40.3	45.4	2.7	3.0	4.0	62
40	89	95.1	7.2	7.9	11.0	105	38.2	44.4	3.5	3.9	5.5	93
50	87	94.1	8.9	9.7	11.0	105	36.2	43.3	4.4	4.8	5.5	93
60	85	93.1	10.6	11.5	15.0	114	34.3	42.4	5.2	5.7	7.5	93
70	83.1	92.2	12.2	13.3	15.0	114	32.3	41.4	6.1	6.6	7.5	93
80	81.2	91.3	13.9	15.1	18.5	124	30.4	40.5	6.9	7.4	11.0	113
90	79.3	90.4	15.6	16.9	18.5	124	28.4	39.7	7.8	8.4	11.0	113
100	77.5	89.6	17.3	18.8	22.0	152	26.5	38.9	8.6	9.2	11.0	113
110	74.5	88.9	19.0	20.6	22.0	152	-	-	-	-	-	-
120	71.6	88.2	20.7	22.4	30.0	206	-	-	-	-	-	-
130	68.8	86.4	22.4	24.2	30.0	206	-	-	-	-	-	-
140	66	84.7	24.0	26.0	30.0	206	-	-	-	-	-	-
150	63.2	83	25.7	27.9	30.0	206	-	-	-	-	-	-

1) Q_{Th} : 理论流量

更高压力(最大 200 bar) 请洽询。
黏度 > 20 mm²/s 更大功率消耗。

特性和尺寸

TFS3, FFS3

50 Hz

安装孔形式

TFS3 / TFS4

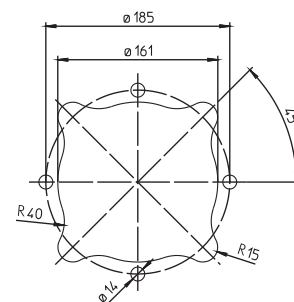
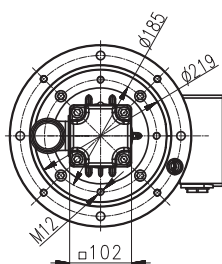

所有角落
必须排除!
根据
ISO 2768-m

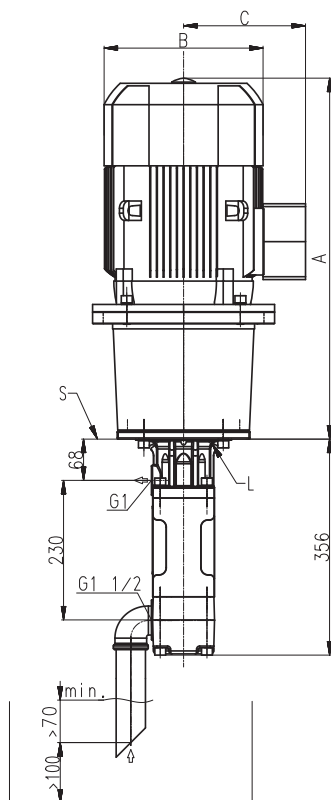

L = 泄漏孔
S = 安装板, 请参考
去除安装孔

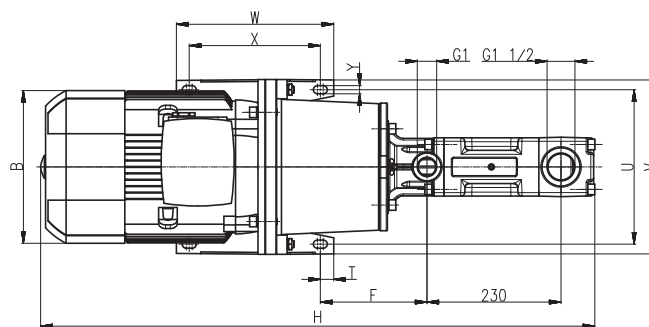
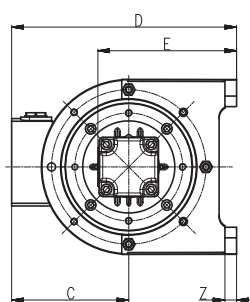
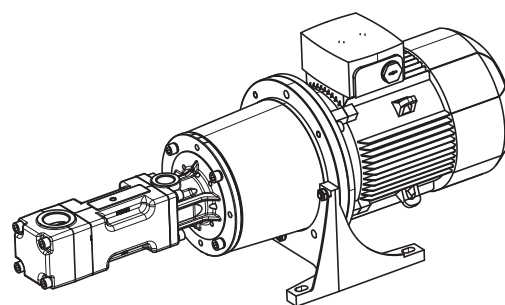

功率 2 极 kW	功率 4 极 kW	A mm	B mm	C mm	D mm	E mm	F mm	H mm	T mm	U mm	V mm	W mm	X mm	Y mm	Z mm
-	1.1 / 1.5	476	178	126	238	165	167	847	15	180	210	90	60	11	12
2.2	-	516	178	126	238	165	167	887	15	180	210	90	60	11	12
3.0	2.2 / 3.0	568	198	166	321	208	186	924	22.5	215	250	230	185	14	15
4.0	4.0	551	222	177	332	208	186	907	22.5	215	250	230	185	14	15
5.5	-	595	262	202	387	238	183	951	22.5	265	300	270	225	14	18
7.5	5.5	645	262	202	387	238	183	1001	22.5	265	300	270	225	14	18
-	7.5	654	262	202	387	238	183	1010	22.5	265	300	270	225	14	18
11.0 / 15.0	11.0	764	314	237	472	288	222	1120	20	300	350	305	265	18	18
18.5	-	824	314	237	472	288	222	1180	20	300	350	305	265	18	18
22.0	-	824	356	286	521	288	222	1180	20	300	350	305	265	18	18
30.0	-	881	396	315	575	313	212	1237	25	350	400	350	300	18	20

TFS4, FFS4

50 Hz

螺杆

最大压力	2 极电机 转速 2900 RPM						4 极电机 转速 1450 RPM					
	流量		功率消耗		电机	重量	流量		功率消耗		电机	重量
	1 mm ² /s	20 mm ² /s	1 mm ² /s	20 mm ² /s			1 mm ² /s	20 mm ² /s	1 mm ² /s	20 mm ² /s		
型号 / bar	l/min	l/min	kW	kW	kW	kg	l/min	l/min	kW	kW	kW	kg
TFS460/	Q _{Th} ¹⁾ 125.3		-	-	-	-	Q _{Th} ¹⁾ 62.7		-	-	-	-
10	118	122	2.7	3.0	4.0	72	55	59	1.2	1.3	2.2	68
20	115	120	4.8	5.2	7.5	96	52	57	2.3	2.4	3.0	68
30	112	118	6.9	7.4	11.0	115	50	56	3.3	3.5	4.0	72
40	110	117	9.0	9.6	11.0	115	47	54	4.4	4.7	5.5	103
50	107	116	11.0	11.8	15.0	124	44	53	5.4	5.8	7.5	103
60	105	114	13.1	14.0	15.0	124	42	52	6.5	6.9	7.5	103
70	102	113	15.2	16.1	18.5	134	40	50	7.5	8.0	11.0	123
80	100	112	17.3	18.3	22.0	162	37	49	8.6	9.1	11.0	123
90	98	111	19.4	20.5	22.0	162	35	48	9.6	10.3	11.0	123
100	96	110	21.5	22.7	30.0	216	32	47	10.7	11.3	15.0	140
110	94	109	23.6	24.9	30.0	216	-	-	-	-	-	-
120	91	108	25.6	27.1	30.0	216	-	-	-	-	-	-
TFS480/	Q _{Th} ¹⁾ 167.1		-	-	-	-	Q _{Th} ¹⁾ 83.6		-	-	-	-
10	157	162	3.4	3.7	5.5	82	74	79	1.6	1.8	2.2	68
20	153	160	6.2	6.6	7.5	96	70	76	3.0	3.2	4.0	72
30	150	158	9.0	9.5	11.0	115	66	74	4.4	4.7	5.5	103
40	146	156	11.7	12.4	15.0	124	63	72	5.8	6.1	7.5	103
50	143	154	14.5	15.2	18.5	134	60	70	7.2	7.6	11.0	123
60	140	152	17.3	18.1	22.0	162	56	68	8.6	9.2	11.0	123
70	137	150	20.1	21.0	22.0	162	53	67	9.9	10.6	11.0	123
80	134	149	22.9	23.9	30.0	216	51	65	11.3	12.1	15.0	140
90	132	147	25.7	26.7	30.0	216	47	64	12.7	13.6	15.0	140
100	129	146	28.5	29.6	30.0	216	44	63	14.1	15.0	18.5	174
110	126	145	31.3	32.5	37.0	237	-	-	-	-	-	-
120	124	144	34.0	35.4	37.0	237	-	-	-	-	-	-
TFS496/	Q _{Th} ¹⁾ 200.5		-	-	-	-	Q _{Th} ¹⁾ 100.3		-	-	-	-
10	189	194	3.9	4.4	5.5	82	89	94	1.9	2.1	3.0	68
20	185	192	7.3	8.0	11.0	115	85	92	3.5	3.9	5.5	103
30	181	190	10.6	11.5	15.0	124	80	90	5.2	5.7	7.5	103
40	177	188	14.0	15.1	18.5	134	76	88	6.9	7.5	11.0	123
50	173	186	17.3	18.6	22.0	162	72	86	8.6	9.3	11.0	123
60	169	184	20.7	22.2	30.0	216	69	84	10.2	11.1	15.0	140
70	166	182	24.0	25.7	30.0	216	65	82	11.9	12.9	15.0	140
80	162	180	27.3	29.3	37.0	237	62	80	13.6	14.8	18.5	174
90	159	179	30.7	32.8	37.0	237	58	78	15.3	16.6	18.5	174
100	156	177	34.0	36.4	45.0	358	55	77	16.9	18.4	22.0	182
110	153	176	37.4	39.9	45.0	358	-	-	-	-	-	-
120	149	174	40.7	43.5	45.0	358	-	-	-	-	-	-

¹⁾ Q_{Th} : 理论流量

黏度 > 20 mm²/s 更大功率消耗。

特性和尺寸

TFS4, FFS4

50 Hz

安装孔形式

TFS3 / TFS4

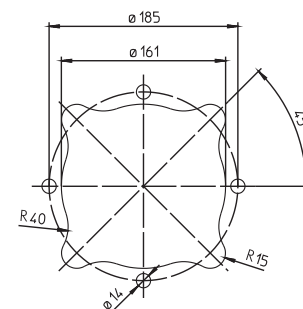
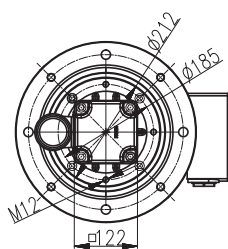

所有角落
必须排除!
根据
ISO 2768-m

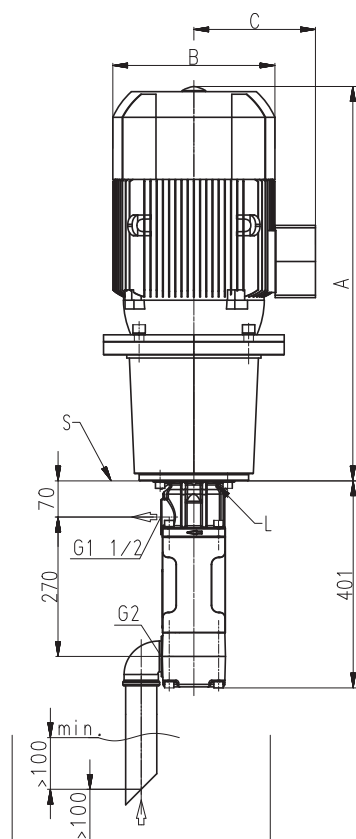

L = 泄漏孔
S = 安装板, 请参考
去除安装孔

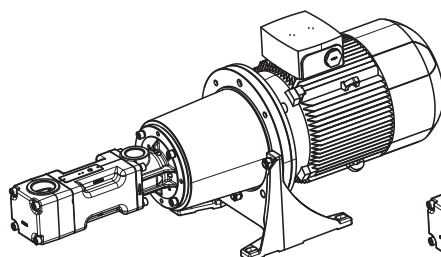

< 45kW

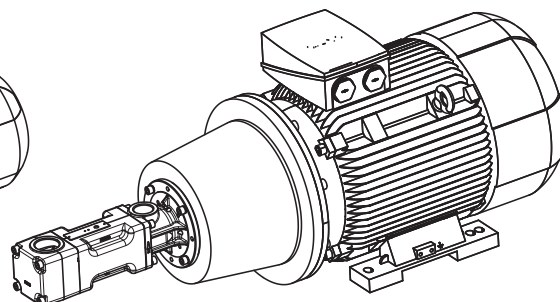

≥ 45kW

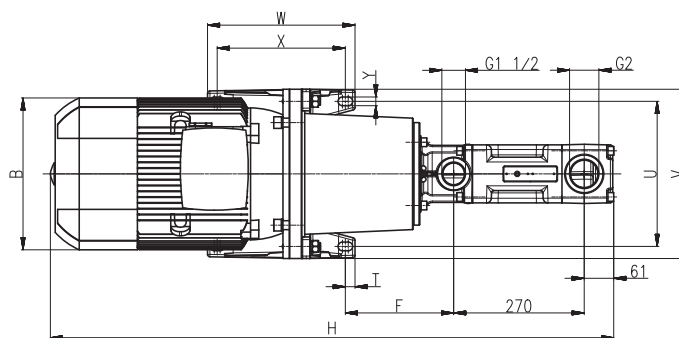
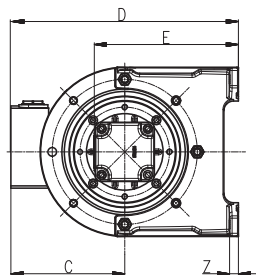

功率 2极 kW	功率 4极 kW	A mm	B mm	C mm	D mm	E mm	F mm	H mm	T mm	U mm	V mm	W mm	X mm	Y mm	Z mm
-	2.2 / 3.0	568	198	166	321	218	188	969	22.5	215	250	230	185	14	15
4.0	4.0	551	222	177	332	218	188	952	22.5	215	250	230	185	14	15
7.5	5.5	659	262	202	387	248	199	1060	22.5	265	300	270	225	14	18
5.5	-	609	262	202	387	248	199	1010	22.5	265	300	270	225	14	18
-	7.5	668	262	202	387	248	199	1069	22.5	265	300	270	225	14	18
11.0 / 15.0	11.0	764	314	237	472	298	224	1165	20	300	350	305	265	18	18
18.5	15.0	824	314	237	472	298	224	1225	20	300	350	305	265	18	18
-	18.5	828	356	286	521	298	224	1229	20	300	350	305	265	18	18
22.0	-	824	356	286	521	298	224	1225	20	300	350	305	265	18	18
-	22.0	858	356	286	521	298	224	1259	20	300	350	305	265	18	18
30.0	-	881	396	315	575	323	214	1282	25	350	400	350	300	18	20
37.0	-	906	396	315	575	323	214	1307	25	350	400	350	300	18	20
45.0	-	984	449	338	563	288	495	1385	25	356	436	361	311	19	34

TFS5, FFS5

50 Hz

螺杆

2 极电机 转速 2900 RPM							4 极电机 转速 1450 RPM					
最大 压力	流量		功率消耗		电机	重量	流量		功率消耗		电机	重量
	1 mm ² /s	20 mm ² /s	1 mm ² /s	20 mm ² /s			1 mm ² /s	20 mm ² /s	1 mm ² /s	20 mm ² /s		
型号 / bar	l/min	l/min	kW	kW	kW	kg	l/min	l/min	kW	kW	kW	kg
TFS574/	Q _{Th} ¹⁾ 241.6		-	-	-	-	Q _{Th} ¹⁾ 120.8		-	-	-	-
10	230	235	5.0	5.7	7.5	123	109	114	2.3	2.7	4.0	99
20	226	233	9.1	9.9	15.0	151	105	112	4.3	4.8	5.5	130
30	222	231	13.1	14.2	18.5	161	101	110	6.3	7.0	7.5	130
40	219	229	17.1	18.4	22.0	189	98	109	8.4	9.1	11.0	150
50	216	228	21.1	22.6	30.0	243	95	107	10.4	11.3	15.0	167
60	213	226	25.2	26.9	30.0	243	92	105	12.4	13.4	15.0	167
70	210	224	29.2	31.1	37.0	264	89	104	14.4	15.5	18.5	201
80	207	223	33.2	35.4	37.0	264	86	102	16.4	17.7	18.5	201
90	204	221	37.2	39.6	45.0	385	83	101	18.4	19.8	22.0	209
100	202	220	41.3	43.8	45.0	385	80	99	20.5	21.9	30.0	259
110	199	219	45.3	48.1	55.0	460	-	-	-	-	-	-
120	196	217	49.3	52.3	55.0	460	-	-	-	-	-	-
TFS5100/	Q _{Th} ¹⁾ 326.5		-	-	-	-	Q _{Th} ¹⁾ 163.3		-	-	-	-
10	310	318	6.4	7.1	11.0	142	147	155	3.0	3.5	5.5	130
20	306	316	11.9	12.9	15.0	151	143	152	5.7	6.4	7.5	130
30	302	313	17.3	18.6	22.0	189	139	150	8.5	9.3	11.0	150
40	298	311	22.8	24.4	30.0	243	135	148	11.2	12.2	15.0	167
50	294	309	28.2	30.2	37.0	264	131	146	13.9	15.1	18.5	201
60	291	307	33.7	36.0	45.0	385	127	144	16.6	18.0	18.5	201
70	287	305	39.1	41.7	45.0	385	124	142	19.3	20.9	22.0	209
80	284	303	44.5	47.5	55.0	460	120	140	22.1	23.9	30.0	259
90	280	302	50.0	53.3	55.0	460	116	138	24.8	26.8	30.0	259
100	277	300	55.4	59.1	75.0	585	113	137	27.5	29.7	37.0	355
110	273	299	60.9	64.8	75.0	585	-	-	-	-	-	-
120	270	297	66.3	70.6	75.0	585	-	-	-	-	-	-

¹⁾ Q_{Th} : 理论流量

黏度 > 20 mm²/s 更大功率消耗。

特性和尺寸

TFS5, FFS5

50 Hz

安装孔形式

TFS5

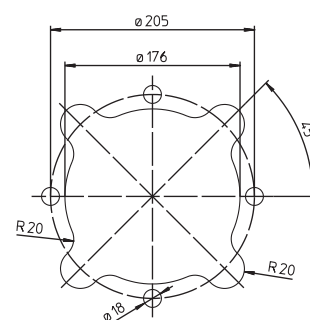

所有角落
必须排除
根据
ISO 2768-m

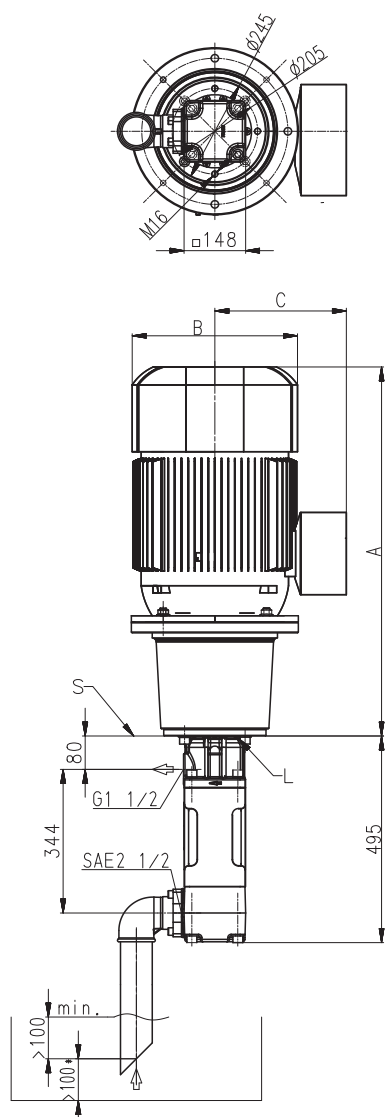

L = 泄漏孔
S = 安装板, 请参考
去除安装孔

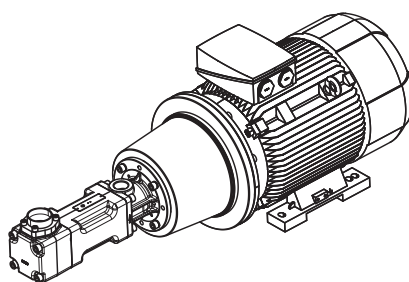

< 45kW

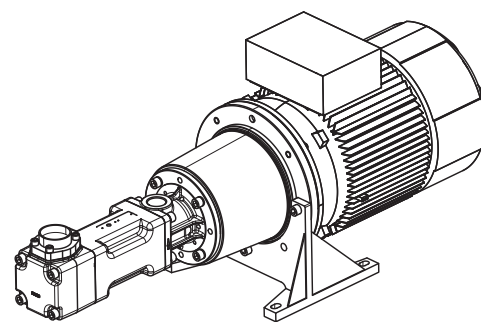

≥ 45kW

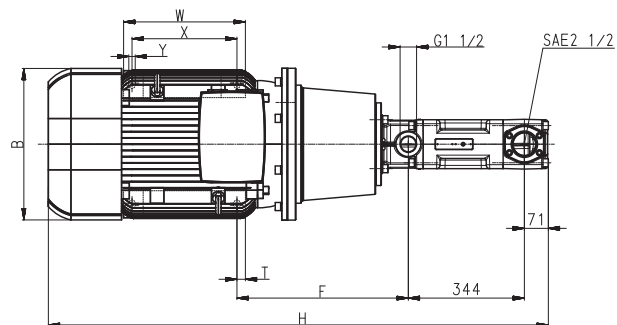
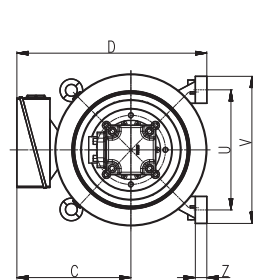

功率 2极 kW	功率 4极 kW	A mm	B mm	C mm	D mm	F mm	H mm	T mm	U mm	V mm	W mm	X mm	Y mm	Z mm
-	4.0	581	222	177	332	228	1076	22.5	215	250	230	185	14	15
7.5	5.5	672	262	202	387	222	1167	22.5	265	300	270	225	14	18
-	7.5	681	262	202	387	222	1176	22.5	265	300	270	225	14	18
11.0 / 15.0	11.0	767	314	237	472	237	1262	20	300	350	305	265	18	18
18.5	15.0	827	314	237	472	237	1322	20	300	350	305	265	18	18
-	18.5	831	356	286	521	237	1326	20	300	350	305	265	18	18
22.0	-	827	356	286	521	237	1322	20	300	350	305	265	18	18
-	22.0	861	356	286	521	237	1356	20	300	350	305	265	18	18
30.0	-	884	396	315	575	227	1379	25	350	400	350	300	18	20
37.0	30.0	909	396	315	575	227	1404	25	350	400	350	300	18	20
-	37.0	929	449	338	633	223	1422	25	400	450	385	335	18	20
45.0	-	987	449	338	563	508	1482	25	356	436	361	311	19	34
55.0	-	1059	497	410	660	560	1554	30	406	490	409	349	24	40
75.0	-	1132	551	433	713	582	1627	55.5	457	540	479	368	24	40

TFS5, FFS5

50 Hz

螺杆

最大 压力	2 极电机 转速 2900 RPM						4 极电机 转速 1450 RPM					
	流量		功率消耗		电机	重量	流量		功率消耗		电机	重量
	1 mm ² /s	20 mm ² /s	1 mm ² /s	20 mm ² /s			1 mm ² /s	20 mm ² /s	1 mm ² /s	20 mm ² /s		
型号 / bar	l/min	l/min	kW	kW	kW	kg	l/min	l/min	kW	kW	kW	kg
TFS5120/	Q _{Th} ¹⁾ 391.8		-	-	-	-	Q _{Th} ¹⁾ 195.9		-	-	-	-
10	372	382	7.5	8.7	11.0	142	176	186	3.6	4.1	5.5	130
20	366	379	14.1	15.6	18.5	161	171	183	6.8	7.6	11.0	150
30	361	376	20.6	22.5	30.0	243	165	180	10.1	11.1	15.0	167
40	355	373	27.1	29.5	37.0	264	160	177	13.4	14.6	18.5	201
50	350	370	33.7	36.4	45.0	385	154	175	16.6	18.1	22.0	209
60	345	368	40.2	43.3	45.0	385	149	172	19.9	21.6	22.0	209
70	340	366	46.7	50.2	55.0	460	144	170	23.2	25.1	30.0	259
80	336	364	53.2	57.1	75.0	585	140	168	26.4	28.6	30.0	259
90	331	362	59.8	64.0	75.0	585	134	166	29.7	32.1	37.0	355
100	327	360	66.3	71.0	75.0	585	129	164	33.0	35.6	37.0	355
110	322	358	72.8	77.9	90.0	665	-	-	-	-	-	-
120	318	357	79.4	84.8	90.0	665	-	-	-	-	-	-
TFS5130/	Q _{Th} ¹⁾ 424.5		-	-	-	-	Q _{Th} ¹⁾ 212.2		-	-	-	-
10	403	412	8.1	9.2	15.0	151	191	199	3.8	4.3	5.5	130
20	396	407	15.1	16.5	18.5	161	184	195	7.4	8.0	11.0	150
30	389	402	22.2	23.7	30.0	243	177	190	10.9	11.7	15.0	167
40	383	398	29.3	31.0	37.0	264	171	186	14.4	15.3	18.5	201
50	377	394	36.4	38.3	45.0	385	165	181	18.0	19.0	22.0	209
60	371	390	43.4	45.6	55.0	460	159	177	21.5	22.7	30.0	259
70	366	386	50.5	52.8	55.0	460	154	174	25.1	26.4	30.0	259
80	361	382	57.6	60.1	75.0	585	149	170	28.6	30.0	37.0	355
90	357	379	64.7	67.4	75.0	585	143	166	32.1	33.7	37.0	355
100	352	375	71.7	74.7	90.0	665	138	163	35.7	37.4	45.0	390
110	347	372	78.8	81.9	90.0	665	-	-	-	-	-	-
120	343	369	85.9	89.2	110.0	825	-	-	-	-	-	-

¹⁾ Q_{Th} : 理论流量

黏度 > 20 mm²/s 更大功率消耗。

特性和尺寸

TFS5, FFS5

50 Hz

安装孔形式

TFS5

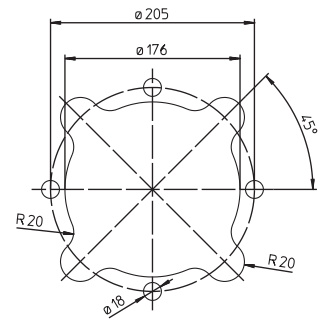

所有角落
必须排除
根据
ISO 2768-m

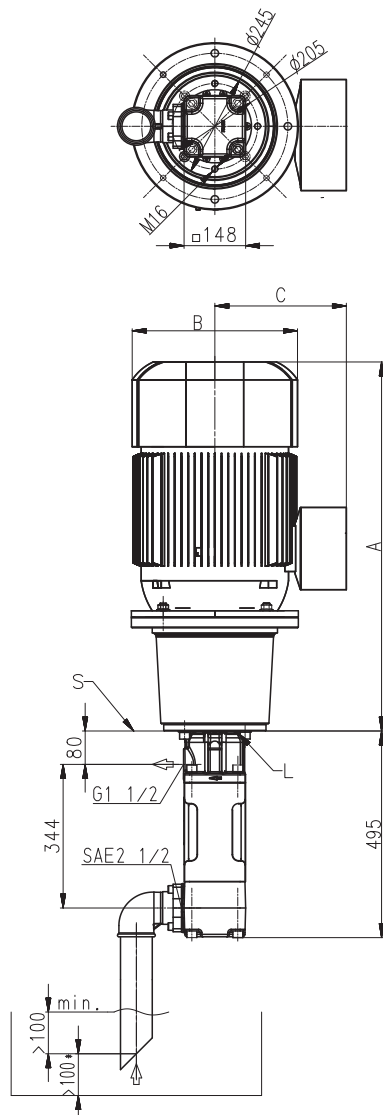

L = 泄漏孔
S = 安装板, 请参考
去除安装孔

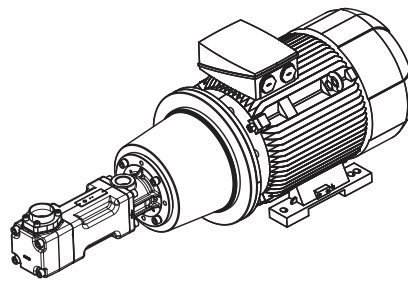

< 45kW

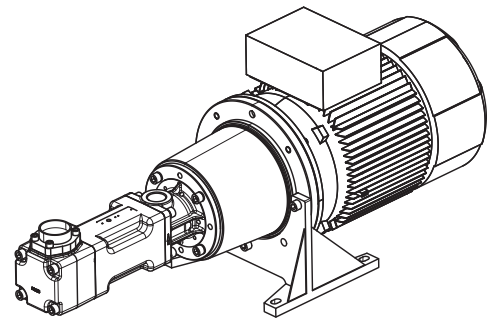

≥ 45kW

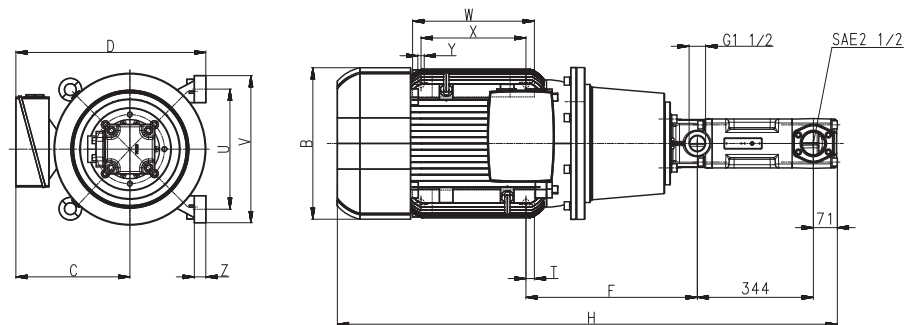

功率 2极 kW	功率 4极 kW	A	B	C	D	F	H	T	U	V	W	X	Y	Z
mm	mm	mm	mm	mm	mm	mm	mm	mm	mm	mm	mm	mm	mm	mm
-	5.5	672	262	202	387	222	1167	22.5	265	300	270	225	14	18
11.0 / 15.0	11.0	767	314	237	472	237	1262	20	300	350	305	265	18	18
-	18.5	827	314	237	472	237	1322	20	300	350	305	265	18	18
-	18.5	831	356	286	521	237	1326	20	300	350	305	265	18	18
-	22.0	861	356	286	521	237	1356	20	300	350	305	265	18	18
30.0	-	884	396	315	575	227	1379	25	350	400	350	300	18	20
37.0	30.0	909	396	315	575	227	1404	25	350	400	350	300	18	20
-	37.0	929	449	338	633	223	1422	25	400	450	385	335	18	20
45.0	45.0	987	449	338	563	508	1482	25	356	436	361	311	19	34
55.0	-	1059	497	410	660	560	1554	30	406	490	409	349	24	40
75.0	-	1132	551	433	713	582	1627	55.5	457	540	479	368	24	40
90.0	-	1243	551	433	713	582	1738	30	457	540	479	419	24	40
110.0	-	1239	616	515	830	623	1734	35	508	610	527	406	28	50

TFS6, FFS6

50 Hz

螺杆

最大压力	2 极电机 转速 2900 RPM						4 极电机 转速 1450 RPM						
	流量		功率消耗		电机	重量	流量		功率消耗		电机	重量	
	1 mm ² /s l/min	20 mm ² /s l/min	1 mm ² /s kW	20 mm ² /s kW			1 mm ² /s l/min	20 mm ² /s l/min	1 mm ² /s kW	20 mm ² /s kW			
型号 / bar	Q _{Th} ¹⁾ 459		-	-	-	-	Q _{Th} ¹⁾ 230		-	-	-	-	
TFS690/	10	445	450	9.5	11.2	15.0	199	216	220	4.4	5.1	7.5	178
	20	437	445	17.1	18.8	22.0	237	207	216	8.3	9.0	11.0	198
	30	429	440	24.8	26.5	30.0	291	199	211	12.1	12.8	15.0	215
	40	421	436	32.4	34.1	37.0	312	191	206	15.9	16.6	18.5	249
	50	414	432	40.1	41.8	45.0	433	184	202	19.7	20.4	22.0	257
	60	407	428	47.7	49.4	55.0	508	177	198	23.6	24.3	30.0	307
	70	401	424	55.4	57.1	75.0	633	171	194	27.4	28.1	30.0	307
	80	395	420	63.0	64.7	75.0	633	165	190	31.2	31.9	37.0	403
TFS6120/	Q _{Th} ¹⁾ 612		-	-	-	-	Q _{Th} ¹⁾ 306		-	-	-	-	
	10	594	600	12.0	13.7	18.5	209	288	294	5.7	6.4	7.5	178
	20	584	594	22.2	23.9	30.0	291	278	288	10.8	11.5	15.0	215
	30	574	588	32.4	34.1	37.0	312	268	282	15.9	16.6	18.5	249
	40	565	583	42.6	44.3	55.0	508	259	277	21.0	21.7	30.0	307
	50	557	578	52.8	54.5	75.0	633	251	272	26.1	26.8	30.0	307
	60	549	573	63.0	64.7	75.0	633	243	267	31.2	31.9	37.0	403
	70	542	568	73.2	74.9	90.0	713	236	262	36.3	37.0	45.0	438
	80	533	563	83.4	85.1	90.0	713	227	257	41.4	42.1	45.0	438
TFS6145/	Q _{Th} ¹⁾ 740		-	-	-	-	Q _{Th} ¹⁾ 370		-	-	-	-	
	10	717	725	14.1	15.8	22.0	237	348	355	6.8	7.5	11.0	198
	20	704	715	26.5	28.2	37.0	312	334	345	12.9	13.6	15.0	215
	30	692	706	38.8	40.5	45.0	433	322	337	19.1	19.8	22.0	257
	40	680	698	51.1	52.8	55.0	508	310	328	25.3	26.0	30.0	307
	50	669	691	63.4	65.1	75.0	633	299	321	31.4	32.1	37.0	403
	60	658	684	75.8	77.5	90.0	713	288	314	37.6	38.3	45.0	438
	70	646	676	88.1	89.8	110.0	872	276	306	43.8	44.5	55.0	543
	80	635	668	100.4	102.1	110.0	872	265	298	49.9	50.6	55.0	543

¹⁾ Q_{Th} : 理论流量

黏度 > 20 mm²/s 更大功率消耗。

所有 6 系列螺杆泵的工作流量在 800 l/min 或以上，必须配备进给泵，提供流体至少 1bar 的压力到泵的入口。

特性和尺寸

TFS6, FFS6

50 Hz

安装孔形式

TFS6

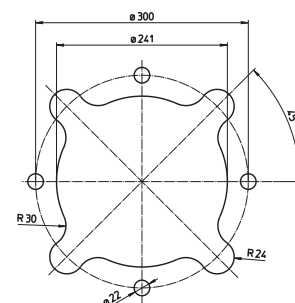

所有角落
必须排除!
根据
ISO 2768-m

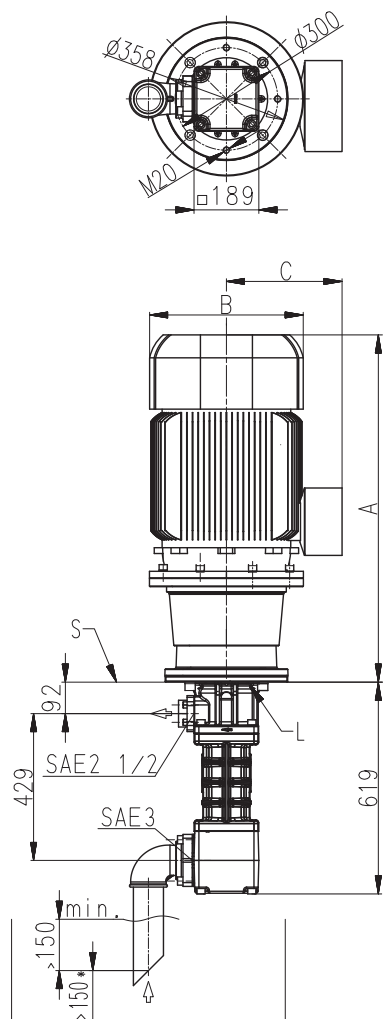

L = 泄漏孔
S = 安装板, 请参考
去除安装孔

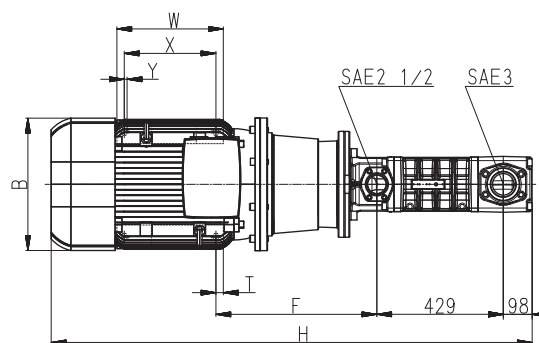
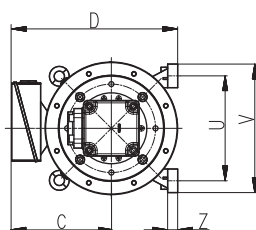
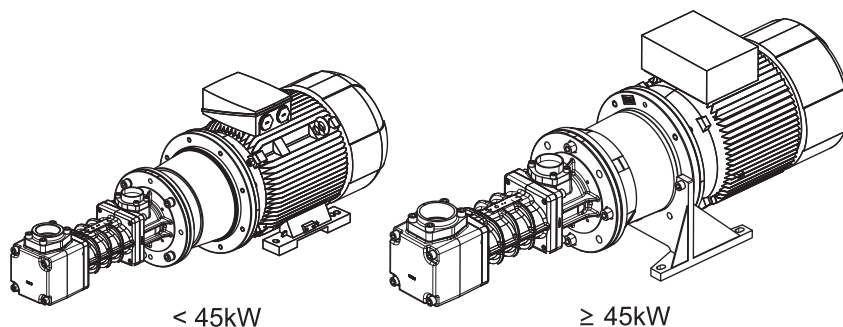

功率 2极 kW	功率 4极 kW	A mm	B mm	C mm	D mm	F mm	H mm	T mm	U mm	V mm	W mm	X mm	Y mm	Z mm
-	7.5	723	262	202	387	242	1342	22.5	265	300	270	225	14	18
-	11.0	795	314	237	472	242	1414	20	300	350	305	265	18	18
15.0	-	795	314	237	497	242	1414	25	350	400	350	300	18	20
-	15.0	855	314	237	472	265	1474	20	300	350	305	265	18	18
18.5	-	855	314	237	497	242	1474	25	350	400	350	300	18	20
-	18.5	859	356	286	521	265	1478	20	300	350	305	265	18	18
22.0	-	855	356	286	546	242	1474	25	350	400	350	300	18	20
-	22.0	889	356	286	521	397	1508	20	300	350	305	265	18	18
30.0	-	910	396	315	575	265	1529	25	350	400	350	300	18	20
-	30.0	935	396	315	575	417	1554	25	350	400	350	300	18	20
37.0	-	935	396	315	575	265	1554	25	350	400	350	300	18	20
-	37.0	973	449	338	575	432	1592	25	400	450	385	335	18	20
45.0	45.0	1013	449	338	563	546	1632	25	356	436	361	311	19	34
55.0	-	1072	497	410	660	585	1691	30	406	490	409	349	24	40
75.0	-	1160	551	433	713	622	1779	55.5	457	540	479	368	24	40
90.0	-	1270	551	433	713	622	1889	30	457	540	479	419	24	40
110.0	-	1242	616	515	830	638	1861	60.5	508	610	527	406	28	50

BFS1, FFS1

螺杆



2 极电机 转速 3500 RPM									4 极电机 转速 1750 RPM							
最大 压力	流量		功率消耗		电机 沉水形式		电机 脚安装形式		重量	流量		功率消耗		电机		重量
	1 mm ² /s	20 mm ² /s	1 mm ² /s	20 mm ² /s	IE3 / NEMA	IE3	NEMA	IE3		1 mm ² /s	20 mm ² /s	1 mm ² /s	20 mm ² /s	IE3	NEMA	
型号 / bar	l/min	l/min	kW	kW	kW	kW	kW	kg	l/min	l/min	kW	kW	kW	kW	kg	
BFS130/	Q _{Th} ¹⁾ 18.8		-	-	-	-	-	-	Q _{Th} ¹⁾ 9.4		-	-	-	-	-	
10	17.3	18.2	0.6	0.6	B 1.49	0.86	0.75	39	7.9	8.8	0.3	0.3	0.86	0.75	30	
20	16.3	17.8	0.9	0.9	B 1.49	1.27	1.1	39	6.9	8.4	0.4	0.4	0.86	0.75	30	
30	15.4	17.5	1.2	1.2	B 1.49	1.75	1.5	39	5.9	8	0.6	0.6	0.86	0.75	30	
40	14.5	17.1	1.5	1.5	B 1.75	1.75	2.2	39	5	7.7	0.7	0.8	1.27	1.1	32	
50	13.6	16.7	1.8	1.9	B 2.18	2.54	2.2	44	4	7.3	0.9	1.0	1.27	1.1	32	
60	12.7	16.4	2.1	2.2	B 2.55	2.54	3.0	44	3.2	7	1.0	1.1	1.27	1.5	32	
70	11.9	16	2.4	2.5	B 2.94	3.45	3.0	45	-	6.6	-	1.3	1.75	1.5	34	
80	11.1	15.7	2.8	2.9	B 3.45	3.45	3.7	57	-	6.3	-	1.5	1.75	2.2	34	
90	10.4	15.4	3.1	3.2	B 3.45	3.45	3.7	57	-	6	-	1.6	1.75	2.2	34	
100	9.6	15.1	3.4	3.5	B 3.8	4.55	3.7	57	-	5.6	-	1.8	2.55	2.2	45	
110	8.7	14.7	3.7	3.9	B 4.55	4.55	5.5	58	-	5.3	-	2.0	2.55	2.2	45	
120	7.8	14.4	4.0	4.2	B 4.55	4.55	5.5	58	-	5	-	2.1	2.55	2.2	45	
130	-	14.1	-	4.5	B 5.75	6.3	5.5	63	-	-	-	-	-	-	-	
140	-	13.8	-	4.9	B 5.75	6.3	5.5	63	-	-	-	-	-	-	-	
150	-	13.5	-	5.2	B 5.75	6.3	5.5	63	-	-	-	-	-	-	-	
BFS140/	Q _{Th} ¹⁾ 25.2		-	-	-	-	-	-	Q _{Th} ¹⁾ 12.6		-	-	-	-	-	
10	23.1	24.4	0.7	0.7	B 1.49	1.27	1.1	39	10.5	11.8	0.3	0.4	0.86	0.75	30	
20	21.8	23.9	1.1	1.2	B 1.49	1.75	1.5	39	9.2	11.3	0.5	0.6	0.86	0.75	30	
30	20.6	23.4	1.5	1.6	B 1.75	1.75	2.2	39	8	10.7	0.7	0.8	1.27	1.1	32	
40	19.5	22.9	1.9	2.0	B 2.18	2.54	2.2	44	6.9	10.2	0.9	1.0	1.27	1.1	32	
50	18.4	22.4	2.4	2.5	B 2.94	3.45	3.0	45	5.8	9.8	1.1	1.2	1.75	1.5	34	
60	17.3	21.9	2.8	2.9	B 3.45	3.45	3.0	57	4.7	9.3	1.3	1.5	1.75	1.5	34	
70	16.4	21.4	3.2	3.3	B 3.8	4.55	3.7	57	3.8	8.8	1.5	1.7	2.55	2.2	45	
80	15.4	20.9	3.6	3.8	B 4.55	4.55	5.5	58	-	8.3	-	1.9	2.55	2.2	45	
90	14.6	20.5	4.0	4.2	B 4.55	4.55	5.5	58	-	7.9	-	2.1	2.55	2.2	45	
100	13.8	20	4.5	4.7	B 5.75	6.3	5.5	63	-	7.4	-	2.3	2.55	3.0	45	
110	12.6	19.6	4.9	5.1	B 5.75	6.3	5.5	63	-	7	-	2.5	3.45	3.0	45	
120	11.6	19.2	5.3	5.5	B 5.75	6.3	5.5	63	-	6.5	-	2.7	3.45	3.0	45	
130	10.6	18.7	5.7	6.0	B 6.3	6.3	7.5	63	-	-	-	-	-	-	-	
140	9.7	18.3	6.1	6.4	B 6.9	8.6	7.5	87	-	-	-	-	-	-	-	
150	8.8	17.9	6.6	6.9	B 7.48	8.6	7.5	87	-	-	-	-	-	-	-	

¹⁾ Q_{Th}: 理论流量

更高压力 (最大 200 bar) 请洽询。

黏度 > 20 mm²/s 更大功率消耗。

特性和尺寸

BFS1, FFS1

60 Hz

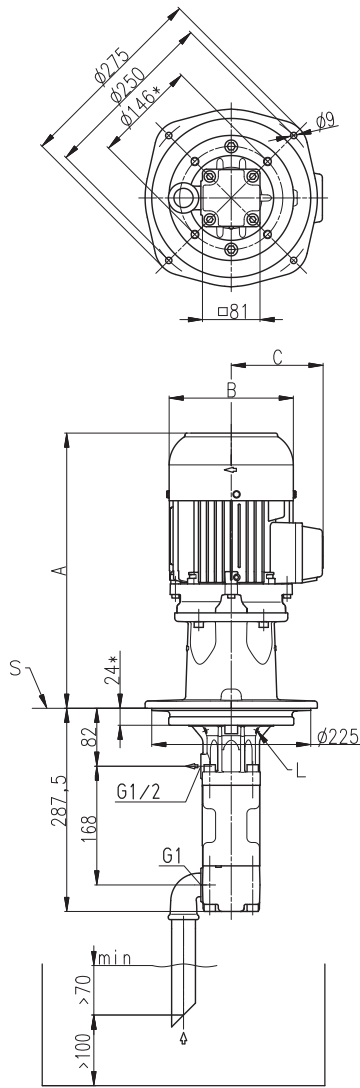

安装孔形式

BFS1 / BFS2

TFS1 / TFS2

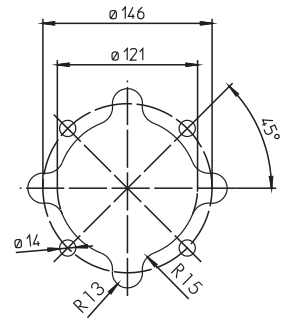
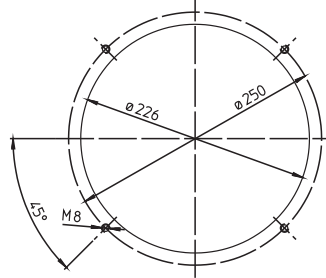

所有角落
必须排除!
根据
ISO 2768-m

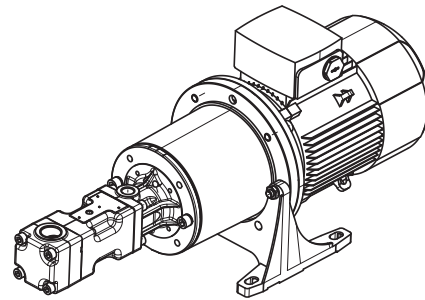

*) 4 极标准尺寸
电机请洽询
L = 泄漏孔
S = 安装板, 请参考
去除安装孔

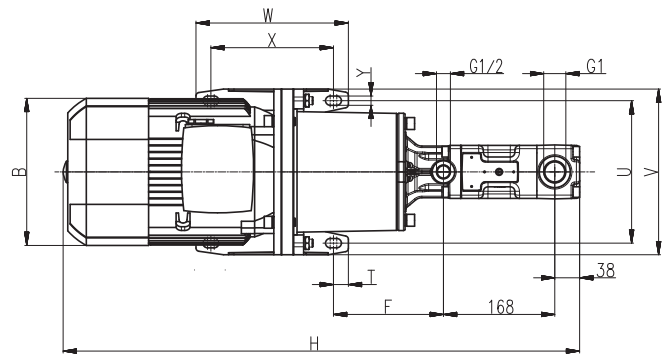
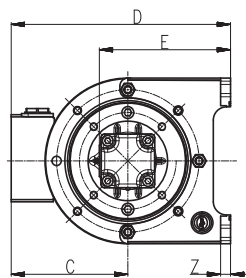

功率 2 极 kW	A mm	B mm	C mm
B 1.49 / 1.75	415	176	130
B 2.18 / 2.55 / 2.94	474	176	130
B 3.45 / 3.8 / 4.55	513	218	150
B 5.75 / 6.3	543	218	150
B 6.9 / 7.48	584	258	193

功率 2 极 kW	功率 4 极 kW	B mm	C mm	D mm	E mm	F mm	H mm	T mm	U mm	V mm	W mm	X mm	Y mm	Z mm
0.75 / 0.86	-	159	121	233	155	138	676	15	180	210	90	60	11	12
-	0.75 / 0.86	159	121	233	155	138	751	15	180	210	90	60	11	12
1.1 / 1.27	-	159	121	233	155	138	711	15	180	210	90	60	11	12
1.5 / 1.75	1.1 / 1.27 / 1.5 / 1.75	178	126	238	155	138	721	15	180	210	90	60	11	12
2.2 / 2.54	-	178	126	238	155	138	761	15	180	210	90	60	11	12
3.0 / 3.45	2.2 / 2.55 / 3.0 / 3.45	198	166	321	198	166	821	22.5	215	250	230	185	14	15
3.7 / 4.55	-	222	177	332	198	166	805	22.5	215	250	230	185	14	15
5.5 / 6.3	-	262	202	387	228	171	857	22.5	265	300	270	225	14	18
7.5 / 8.6	-	262	202	387	228	171	907	22.5	265	300	270	225	14	18

BFS2, FFS2

螺杆

60 Hz

2 极电机 转速 3500 RPM									4 极电机 转速 1750 RPM							
最大 压力	流量		功率消耗		电机 沉水形式		电机 脚安装形式		重量	流量		功率消耗		电机		重量
	1 mm ² /s l/min	20 mm ² /s l/min	1 mm ² /s kW	20 mm ² /s kW	IE3 / NEMA kW	IE3 kW	NEMA kW	IE3 kg		1 mm ² /s l/min	20 mm ² /s l/min	1 mm ² /s kW	20 mm ² /s kW	IE3 kW	NEMA kW	
型号 / bar	Q _{Th} ¹⁾ 31.5		-	-	-	-	-	-	-	Q _{Th} ¹⁾ 15.8		-	-	-	-	-
BFS232/	10	29.7 30.8	0.8	0.9	B 1.49	1.27	1.5	40	40	13.9	15.1	0.4	0.5	0.86	0.75	31
	20	29 30.6	1.4	1.4	B 1.75	1.75	2.2	40	40	13.3	14.8	0.7	0.7	0.86	1.1	31
	30	28.4 30.3	1.9	2.0	B 2.18	2.54	2.2	45	45	12.7	14.6	0.9	1.0	1.27	1.1	33
	40	27.8 30	2.4	2.5	B 2.94	3.45	3.0	46	46	12.1	14.3	1.2	1.3	1.75	1.5	35
	50	27.2 29.8	2.9	3.1	B 3.45	3.45	3.7	58	58	11.5	14	1.4	1.5	1.75	2.2	35
	60	26.6 29.5	3.5	3.6	B 3.8	4.55	3.7	58	58	10.9	13.8	1.7	1.8	2.55	2.2	46
	70	26 29.3	4.0	4.2	B 4.55	4.55	5.5	59	59	10.3	13.5	2.0	2.1	2.55	2.2	46
	80	25.4 29	4.5	4.7	B 5.75	6.3	5.5	64	64	9.7	13.3	2.2	2.3	2.55	3.0	46
	90	24.9 28.7	5.0	5.3	B 5.75	6.3	5.5	64	64	9.1	13	2.5	2.6	3.45	3.0	46
	100	24.3 28.5	5.6	5.8	B 6.3	6.3	7.5	64	64	8.5	12.7	2.7	2.9	3.45	3.0	46
	110	23.8 28.3	6.1	6.4	B 6.9	8.6	7.5	87	87	-	12.5	-	3.2	3.45	3.7	46
	120	23.2 28	6.6	6.9	B 7.48	8.6	7.5	87	87	-	12.3	-	3.4	4.55	3.7	50
	130	22.7 27.8	7.1	7.5	B 8.6	8.6	11.0	94	94	-	12	-	3.7	4.55	3.7	50
	140	22.1 27.5	7.7	8.0	B 8.6	8.6	11.0	94	94	-	11.8	-	4.0	4.55	5.5	50
	150	21.6 27.3	8.2	8.6	B 10.3	12.6	11.0	100	100	-	11.6	-	4.2	4.55	5.5	50
BFS238/	Q _{Th} ¹⁾ 37.4		-	-	-	-	-	-	-	Q _{Th} ¹⁾ 18.7		-	-	-	-	-
	10	35.2 36.5	0.9	0.9	B 1.49	1.27	1.5	40	40	16.5	17.8	0.4	0.4	0.86	0.75	31
	20	34.5 36.2	1.6	1.6	B 1.95	2.54	2.2	41	41	15.8	17.5	0.8	0.8	1.27	1.1	33
	30	33.8 35.9	2.2	2.2	B 2.55	2.54	3.0	45	45	15.1	17.2	1.1	1.1	1.27	1.5	33
	40	33.1 35.6	2.8	2.9	B 3.45	3.45	3.7	58	58	14.4	16.9	1.4	1.4	1.75	2.2	35
	50	32.4 35.3	3.4	3.5	B 3.8	4.55	3.7	58	58	13.7	16.6	1.7	1.8	2.55	2.2	46
	60	31.7 35.1	4.1	4.2	B 4.55	4.55	5.5	59	59	13	16.4	2.0	2.1	2.55	2.2	46
	70	31 34.8	4.7	4.8	B 5.75	6.3	5.5	64	64	12.3	16.1	2.3	2.4	3.45	3.0	46
	80	30.3 34.5	5.3	5.5	B 5.75	6.3	7.5	64	64	11.6	15.8	2.6	2.7	3.45	3.0	46
	90	29.6 34.2	5.9	6.1	B 6.3	6.3	7.5	64	64	10.9	15.5	2.9	3.1	3.45	3.7	46
	100	29 34	6.6	6.8	B 8.6	8.6	7.5	94	94	10.2	15.3	3.2	3.4	4.55	3.7	50
	110	28.3 33.7	7.2	7.4	B 8.6	8.6	11.0	94	94	-	15	-	3.7	4.55	3.7	50
	120	27.6 33.4	7.8	8.1	B 8.6	8.6	11.0	94	94	-	14.7	-	4.1	4.55	5.5	50
	130	27 33.1	8.4	8.8	B 10.3	12.6	11.0	100	100	-	14.4	-	4.4	6.3	5.5	82
	140	26.3 32.9	9.0	9.4	B 10.3	12.6	11.0	100	100	-	14.2	-	4.7	6.3	5.5	82
	150	25.7 32.6	9.7	10.1	B 12.6	12.6	11.0	122	122	-	13.9	-	5.0	6.3	5.5	82

¹⁾ Q_{Th}: 理论流量

更高压力(最大 200 bar) 请洽询。

黏度 > 20 mm²/s 更大功率消耗。

特性和尺寸

BFS2, FFS2

60 Hz

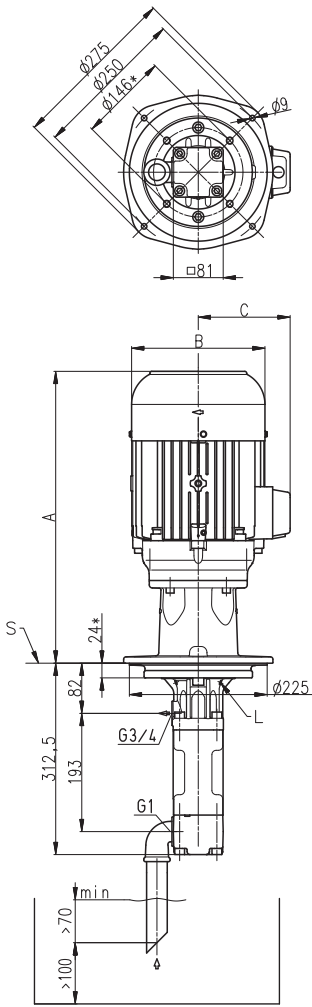

安装孔形式

BFS1 / BFS2

TFS1 / TFS2

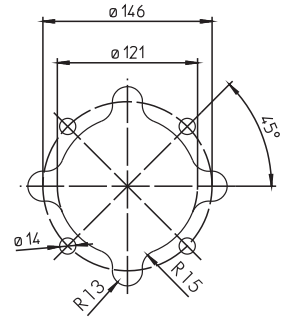
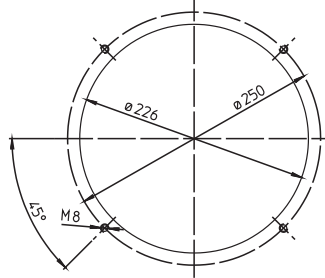

所有角落
必须排除!
根据
ISO 2768-m

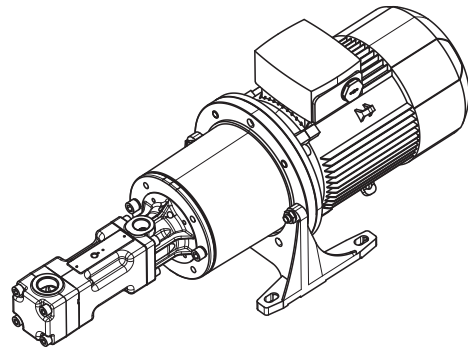

*) 4 极标准尺寸
电机请洽询

L = 泄漏孔
S = 安装板, 请参考
去除安装孔

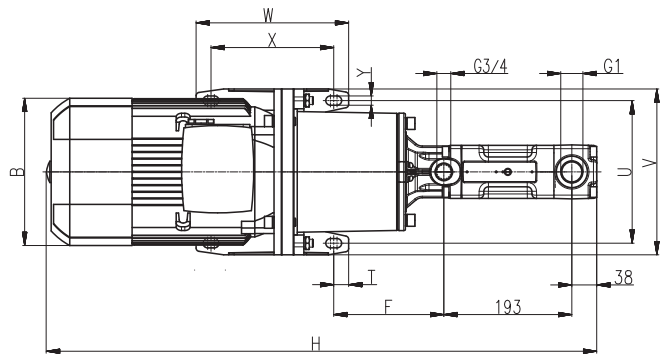
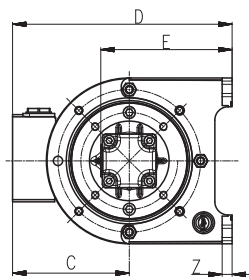

功率 2 极 kW	A mm	B mm	C mm
B 1.49 / 1.75	415	176	130
B 1.95	441	176	130
B 2.18 / 2.55 / 2.94	474	176	130
B 3.45 / 3.8 / 4.55	513	218	150
B 5.75 / 6.3	543	218	150
B 6.9 / 7.48	584	258	193
B 8.6 / 10.3	622	258	193
B 12.6	630	310	240

功率 2 极 kW	功率 4 极 kW	B mm	C mm	D mm	E mm	F mm	H mm	T mm	U mm	V mm	W mm	X mm	Y mm	Z mm
-	0.75 / 0.86	159	121	233	155	138	776	15	180	210	90	60	11	12
1.5 / 1.75	1.1 / 1.27 / 1.5 / 1.75	178	126	238	155	138	746	15	180	210	90	60	11	12
1.27	-	159	121	233	155	138	736	15	180	210	90	60	11	12
2.2 / 2.54	-	178	126	238	155	138	786	15	180	210	90	60	11	12
3.0 / 3.45	2.2 / 2.55 / 3.0 / 3.45	198	166	321	198	166	846	22.5	215	250	230	185	14	15
3.7 / 4.55	3.7 / 4.55	222	177	332	198	166	830	22.5	215	250	230	185	14	15
5.5 / 6.3	-	262	202	387	228	171	882	22.5	265	300	270	225	14	18
7.5 / 8.6	5.5 / 6.3	262	202	387	228	171	932	22.5	265	300	270	225	14	18
11.0 / 12.6	-	314	237	472	278	210	1051	20	300	350	305	265	18	18

BFS2, FFS2

螺杆



2 极电机 转速 3500 RPM									4 极电机 转速 1750 RPM							
最大 压力	流量		功率消耗		电机 沉水形式		电机 脚安装形式		重量	流量		功率消耗		电机		重量
	1 mm ² /s	20 mm ² /s	1 mm ² /s	20 mm ² /s	IE3 / NEMA	IE3	NEMA	IE3		1 mm ² /s	20 mm ² /s	1 mm ² /s	20 mm ² /s	IE3	NEMA	
型号 / bar	l/min	l/min	kW	kW	kW	kW	kW	kg	l/min	l/min	kW	kW	kW	kW	kg	
BFS250/	Q _{Th} ¹⁾ 49.2		-	-	-	-	-	-	Q _{Th} ¹⁾ 24.6		-	-	-	-	-	
10	46.4	48	1.1	1.2	B 1.75	1.75	2.2	40	21.8	23.4	0.5	0.6	0.86	0.75	31	
20	45.4	47.7	2.0	2.0	B 2.55	2.54	3.0	45	20.8	23	1.0	1.0	1.27	1.5	33	
30	44.5	47.3	2.8	2.9	B 3.45	3.45	3.7	58	19.9	22.7	1.4	1.4	1.75	2.2	35	
40	43.6	46.9	3.6	3.8	B 4.55	4.55	5.5	59	19	22.3	1.8	1.9	2.55	2.2	46	
50	42.7	46.6	4.4	4.6	B 5.75	6.3	5.5	64	18.1	21.9	2.2	2.3	2.55	3.0	46	
60	41.9	46.2	5.2	5.5	B 5.75	6.3	7.5	64	17.3	21.6	2.6	2.7	3.45	3.0	46	
70	41.1	45.8	6.1	6.3	B 8.6	8.6	7.5	94	16.5	21.2	3.0	3.2	3.45	3.7	46	
80	40.3	45.4	6.9	7.2	B 8.6	8.6	11.0	94	15.7	20.8	3.4	3.6	4.55	3.7	50	
90	39.6	45.1	7.7	8.1	B 8.6	8.6	11.0	94	14.9	20.4	3.8	4.0	4.55	5.5	50	
100	38.9	44.7	8.5	8.9	B 10.3	12.6	11.0	100	14	20.1	4.2	4.5	6.3	5.5	82	
110	37.6	44.3	9.3	9.8	B 10.3	12.6	11.0	100	-	19.7	-	4.9	6.3	5.5	82	
120	36.3	43.9	10.2	10.5	B 12.6	12.6	11.0	122	-	19.3	-	5.3	6.3	5.5	82	
130	35.1	43.5	11.0	11.5	B 12.6	12.6	15.0	122	-	18.9	-	5.8	6.3	7.5	82	
140	33.8	43.1	11.8	12.3	B 15.0	17.3	15.0	122	-	18.5	-	6.2	8.6	7.5	82	
150	32.6	42.7	12.6	13.2	B 15.0	17.3	15.0	122	-	18.1	-	6.6	8.6	7.5	82	
BFS260/	Q _{Th} ¹⁾ 59		-	-	-	-	-	-	Q _{Th} ¹⁾ 29.5		-	-	-	-	-	
10	55.6	57.6	1.3	1.5	B 2.18	2.54	2.2	45	26.1	28	0.6	0.7	1.27	1.1	33	
20	54.4	57	2.3	2.5	B 3.45	3.45	3.0	58	24.9	27.5	1.1	1.3	1.75	1.5	35	
30	53.3	56.4	3.3	3.6	B 4.55	4.55	5.5	59	23.8	26.9	1.6	1.8	2.55	2.2	46	
40	52.1	55.8	4.3	4.6	B 5.75	6.3	5.5	64	22.6	26.3	2.1	2.3	2.55	3.0	46	
50	51	55.2	5.2	5.7	B 6.3	6.3	7.5	64	21.5	25.7	2.6	2.9	3.45	3.0	46	
60	49.8	54.6	6.2	6.7	B 8.6	8.6	7.5	94	20.3	25.1	3.1	3.4	4.55	3.7	50	
70	48.6	54	7.2	7.8	B 8.6	8.6	11.0	94	19.1	24.5	3.6	3.9	4.55	5.5	50	
80	47.5	53.4	8.2	8.8	B 10.3	12.6	11.0	100	18	23.9	4.1	4.4	6.3	5.5	82	
90	46.3	52.8	9.2	9.9	B 12.6	12.6	11.0	122	16.8	23.2	4.6	5.0	6.3	5.5	82	
100	45.1	52.1	10.2	11.0	B 12.6	12.6	15.0	122	15.7	22.6	5.1	5.5	6.3	5.5	82	
110	43.5	51.5	11.2	12.1	B 12.6	12.6	15.0	122	-	22	-	6.0	6.3	7.5	82	
120	41.9	50.8	12.1	13.1	B 15.0	17.3	15.0	122	-	21.3	-	6.6	8.6	7.5	82	
130	40.2	49.6	13.1	14.2	B 15.0	17.3	15.0	122	-	-	-	-	-	-	-	
140	38.6	48.3	14.1	15.2	-	17.3	18.5	103	-	-	-	-	-	-	-	
150	37	47.1	15.1	16.3	-	17.3	18.5	103	-	-	-	-	-	-	-	

¹⁾ Q_{Th} : 理论流量

更高压力 (最大 200 bar) 请洽询。

黏度 > 20 mm²/s 更大功率消耗。

特性和尺寸

BFS2, FFS2

60 Hz

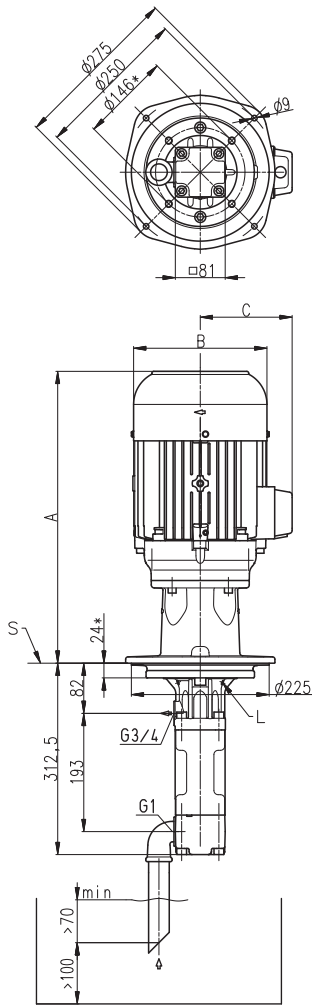

安装孔形式

BFS1 / BFS2

TFS1 / TFS2

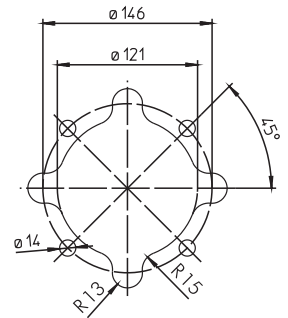
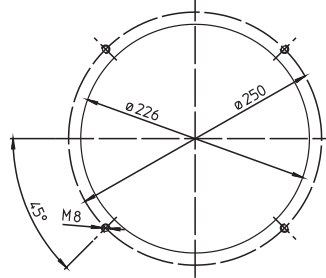

所有角落
必须排除!
根据
ISO 2768-m

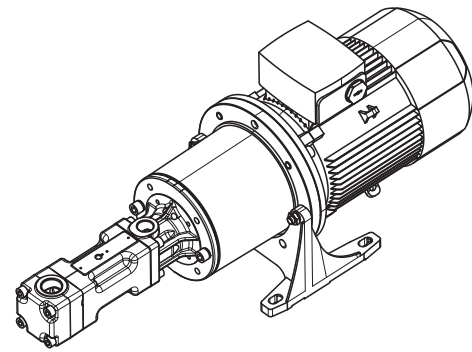

*) 4 极标准尺寸
电机请洽询

L = 泄漏孔
S = 安装板, 请参考
去除安装孔

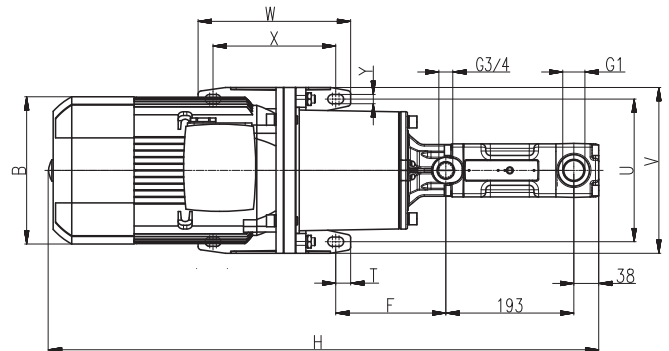
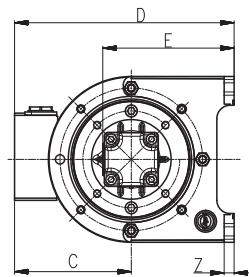

功率 2 极 kW	A mm	B mm	C mm
B 1.75	415	176	130
B 2.18 / 2.55	474	176	130
B 3.45 / 4.55	513	218	150
B 5.75 / 6.3	543	218	150
B 8.6 / 10.3	622	258	193
B 12.6 / 15.0	630	310	240

功率 2 极 kW	功率 4 极 kW	B mm	C mm	D mm	E mm	F mm	H mm	T mm	U mm	V mm	W mm	X mm	Y mm	Z mm
-	0.75 / 0.86	159	121	233	155	138	776	15	180	210	90	60	11	12
1.75	1.1 / 1.27 / 1.5 / 1.75	178	126	238	155	138	746	15	180	210	90	60	11	12
2.2 / 2.54	-	178	126	238	155	138	786	15	180	210	90	60	11	12
3.0 / 3.45	2.2 / 2.55 / 3.0 / 3.45	198	166	321	198	166	846	22.5	215	250	230	185	14	15
3.7 / 4.55	3.7 / 4.55	222	177	332	198	166	830	22.5	215	250	230	185	14	15
5.5 / 6.3	-	262	202	387	228	171	882	22.5	265	300	270	225	14	18
7.5 / 8.6	5.5 / 6.3	262	202	387	228	171	932	22.5	265	300	270	225	14	18
-	7.5 / 8.6	262	202	387	228	171	940	22.5	265	300	270	225	14	18
11.0 / 12.6 / 15.0 / 17.3	-	314	237	472	278	210	1051	20	300	350	305	265	18	18
18.5	-	314	237	472	278	210	1111	20	300	350	305	265	18	18

TFS3, FFS3

螺杆



型号 / bar	2 极电机 转速 3500 RPM								4 极电机 转速 1750 RPM							
	流量		功率消耗		电机		重量	流量		功率消耗		电机		重量		
	1 mm ² /s l/min	20 mm ² /s l/min	1 mm ² /s kW	20 mm ² /s kW	IE3 kW	NEMA kW		IE3 kg	1 mm ² /s l/min	20 mm ² /s l/min	1 mm ² /s kW	20 mm ² /s kW	IE3 kW		NEMA kW	IE3 kg
TFS348/	Q _{Th} ¹⁾ 77.4		-	-	-	-	-	Q _{Th} ¹⁾ 38.7		-	-	-	-	-		
10	73.3	75.6	1.8	1.9	2.54	3.0	47	34.6	36.9	0.8	0.8	1.27	1.1	44		
20	71.8	74.7	3.1	3.3	4.55	3.7	62	33.1	36	1.5	1.5	1.75	2.2	47		
30	70.3	73.9	4.4	4.6	6.3	5.5	72	31.7	35.3	2.1	2.2	2.55	3.0	58		
40	69	73.2	5.7	6.0	8.6	7.5	86	30.3	34.5	2.8	2.9	3.45	3.7	58		
50	67.6	72.5	6.9	7.3	8.6	11.0	86	28.9	33.8	3.4	3.6	4.55	5.5	62		
60	66.4	71.8	8.2	8.6	12.6	11.0	105	27.7	33.1	4.1	4.3	6.3	5.5	93		
70	65.2	71.1	9.5	10.0	12.6	11.0	105	26.5	32.4	4.7	5.0	6.3	5.5	93		
80	64	70.5	10.8	11.3	12.6	15.0	105	25.3	31.8	5.4	5.7	6.3	7.5	93		
90	62.9	69.9	12.1	12.7	17.3	15.0	114	24	31.3	6.0	6.4	8.6	7.5	93		
100	61.9	69.4	13.4	14.0	17.3	15.0	114	22.8	30.7	6.7	7.1	8.6	7.5	93		
110	60	68.9	14.7	15.3	17.3	18.5	114	-	30.2	-	7.8	8.6	11.0	93		
120	58.2	68.4	15.9	16.7	17.3	18.5	114	-	29.8	-	8.5	12.6	11.0	113		
130	56.6	68	17.2	18.0	21.3	18.5	124	-	29.3	-	9.2	12.6	11.0	113		
140	54.9	67.6	18.5	19.3	21.3	22.0	124	-	28.9	-	9.9	12.6	11.0	113		
150	53.3	67.3	19.8	20.7	25.3	22.0	152	-	28.6	-	10.6	12.6	11.0	113		
TFS364/	Q _{Th} ¹⁾ 103.2		-	-	-	-	-	Q _{Th} ¹⁾ 51.6		-	-	-	-	-		
10	97.5	100.7	2.2	2.4	4.55	5.5	62	45.9	49.1	1.1	1.1	1.75	1.5	47		
20	95.8	99.7	3.9	4.2	6.3	5.5	72	44.2	48.1	1.9	2.0	2.55	2.2	58		
30	94	98.7	5.7	6.0	8.6	7.5	86	42.4	47.1	2.8	2.9	3.45	3.7	58		
40	92.3	97.8	7.4	7.7	12.6	11.0	105	40.7	46.2	3.6	3.8	4.55	5.5	62		
50	90.7	96.9	9.1	9.5	12.6	11.0	105	39.1	45.3	4.5	4.7	6.3	5.5	93		
60	89.1	96.1	10.8	11.3	12.6	15.0	105	37.5	44.5	5.4	5.6	6.3	7.5	93		
70	87.5	95.3	12.5	13.1	17.3	15.0	114	35.9	43.7	6.2	6.5	8.6	7.5	93		
80	86	94.5	14.3	14.9	17.3	18.5	114	34.4	42.9	7.1	7.4	8.6	11.0	93		
90	84.6	93.8	16.0	16.7	17.3	18.5	114	32.8	42.2	7.9	8.3	8.6	11.0	93		
100	83.2	93.2	17.7	18.4	21.3	22.0	124	31.2	41.6	8.8	9.2	12.6	11.0	113		
110	80.9	92.5	19.4	20.2	21.3	22.0	124	-	40.9	-	10.1	12.6	11.0	113		
120	78.6	91.9	21.2	22.0	25.3	22.0	152	-	40.3	-	11.0	12.6	11.0	113		
130	76.4	90.4	22.9	23.8	25.3	30.0	152	-	-	-	-	-	-	-		
140	74.3	89	24.6	25.6	33.5	30.0	206	-	-	-	-	-	-	-		
150	72.2	87.5	26.3	27.3	33.5	30.0	206	-	-	-	-	-	-	-		
TFS376/	Q _{Th} ¹⁾ 122.5		-	-	-	-	-	Q _{Th} ¹⁾ 61.3		-	-	-	-	-		
10	116.2	119.5	2.5	2.8	6.3	7.5	72	55	58.3	1.2	1.3	1.75	2.2	47		
20	114.1	118.3	4.6	4.9	8.6	7.5	86	52.8	57.1	2.2	2.4	3.45	3.0	58		
30	112	117.2	6.6	7.1	8.6	11.0	86	50.8	55.9	3.3	3.5	4.55	5.5	62		
40	110	116.1	8.7	9.2	12.6	11.0	105	48.7	54.9	4.3	4.6	6.3	5.5	93		
50	108	115.1	10.7	11.3	12.6	15.0	105	46.7	53.8	5.3	5.7	6.3	7.5	93		
60	106	114.1	12.8	13.5	17.3	15.0	114	44.8	52.9	6.3	6.7	8.6	7.5	93		
70	104.1	113.2	14.8	15.6	17.3	18.5	114	42.8	51.9	7.3	7.8	8.6	11.0	93		
80	102.2	112.3	16.8	17.8	21.3	22.0	124	40.9	51	8.4	8.9	12.6	11.0	113		
90	100.3	111.4	18.9	19.9	21.3	22.0	124	38.9	50.2	9.4	10.0	12.6	11.0	113		
100	98.5	110.6	20.9	22.0	25.3	30.0	152	37	49.4	10.4	11.1	12.6	15.0	113		
110	95.5	109.9	23.0	24.2	25.3	30.0	152	-	48.6	-	12.2	12.6	15.0	113		
120	92.6	109.2	25.0	26.3	33.5	30.0	206	-	48	-	13.3	17.3	15.0	130		
130	89.8	107.4	27.1	28.5	33.5	30.0	206	-	-	-	-	-	-	-		
140	87	105.7	29.1	30.6	33.5	37.0	206	-	-	-	-	-	-	-		
150	84.2	104	31.1	32.7	41.5	37.0	227	-	-	-	-	-	-	-		

1) Q_{Th} : 理论流量

更高压力(最大 200 bar) 请洽询。

黏度 > 20 mm²/s 更大功率消耗。

特性和尺寸

TFS3, FFS3

60 Hz

安装孔形式

TFS3 / TFS4

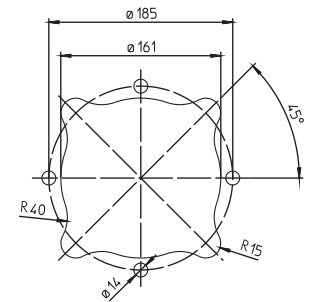
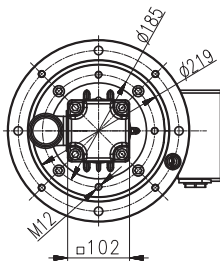

所有角落
必须排除!
根据
ISO 2768-m

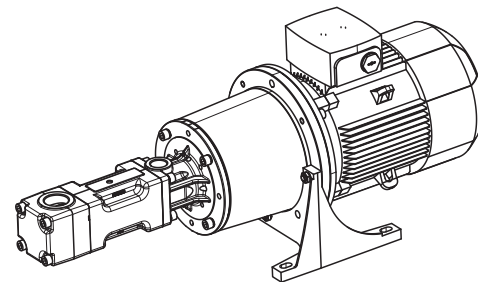
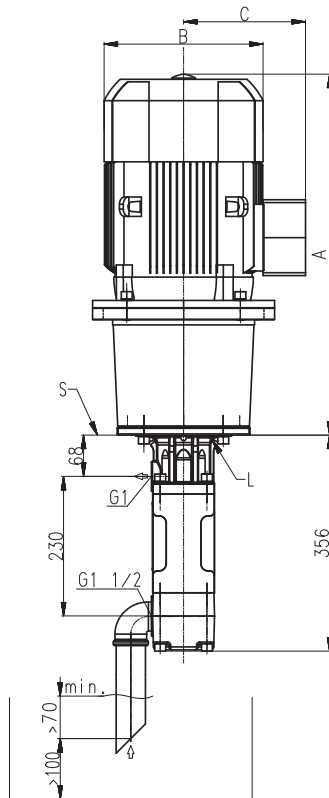

L = 泄漏孔
S = 安装板, 请参考
去除安装孔

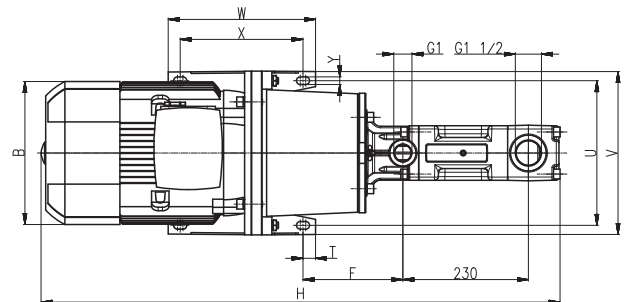
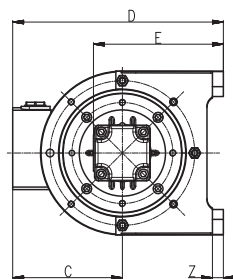

功率 2 极 kW	功率 4 极 kW	A	B	C	D	E	F	H	T	U	V	W	X	Y	Z
		mm	mm	mm	mm	mm	mm	mm	mm	mm	mm	mm	mm	mm	mm
-	1.1 / 1.27 / 1.5 / 1.75	476	178	126	238	165	167	847	15	180	210	90	60	11	12
3.0	2.2 / 2.55 / 3.0 / 3.45	568	198	166	321	208	186	924	22.5	215	250	230	185	14	15
2.54	-	516	178	126	238	165	167	887	15	180	210	90	60	11	12
3.7 / 4.55	3.7 / 4.55	551	222	177	332	208	186	907	22.5	215	250	230	185	14	15
5.5 / 6.3	-	595	262	202	387	238	183	951	22.5	265	300	270	225	14	18
7.5 / 8.6	5.5 / 6.3	645	262	202	387	238	183	1001	22.5	265	300	270	225	14	18
-	7.5 / 8.6	654	262	202	387	238	183	1010	22.5	265	300	270	225	14	18
11.0 / 12.6 / 15.0 / 17.3	11.0 / 12.6	764	314	237	472	288	222	1120	20	300	350	305	265	18	18
18.5 / 21.3	15.0 / 17.3	824	314	237	472	288	222	1180	20	300	350	305	265	18	18
22.0 / 25.3	-	824	356	286	521	288	222	1180	20	300	350	305	265	18	18
30.0 / 33.5	-	881	396	315	575	313	212	1237	25	350	400	350	300	18	20
37.0 / 41.5	-	906	396	315	575	313	212	1262	25	350	400	350	300	18	20

TFS4, FFS4

螺杆



		2 极电机 转速 3500 RPM						4 极电机 转速 1750 RPM						
最大 压力	流量		功率消耗		电机		重量	流量		功率消耗		电机		重量
	1 mm ² /s l/min	20 mm ² /s l/min	1 mm ² /s kW	20 mm ² /s kW	IE3 kW	NEMA kW		IE3 kg	1 mm ² /s l/min	20 mm ² /s l/min	1 mm ² /s kW	20 mm ² /s kW	IE3 kW	
型号 / bar	Q _{Th} ¹⁾		-		-		-	Q _{Th} ¹⁾		-		-		-
TFS460/	151.2		-		-		-	75.6		-		-		-
10	144	147	3.3	3.7	4.55	5.5	72	68	72	1.6	1.6	2.55	2.2	68
20	141	146	5.8	6.4	8.6	7.5	96	65	70	2.8	2.9	3.45	3.7	68
30	138	144	8.4	9.0	12.6	11.0	115	63	69	4.1	4.3	4.55	5.5	72
40	136	143	10.9	11.7	12.6	15.0	115	60	67	5.3	5.6	6.3	7.5	103
50	133	142	13.4	14.4	17.3	18.5	124	57	66	6.6	7.0	8.6	7.5	103
60	131	140	15.9	17.0	21.3	18.5	134	55	65	7.9	8.4	8.6	11.0	103
70	128	139	18.4	19.7	21.3	22.0	134	53	63	9.1	9.7	12.6	11.0	123
80	126	138	21.0	22.3	25.3	30.0	162	50	62	10.4	11.1	12.6	15.0	123
90	124	137	23.5	25.0	33.5	30.0	216	48	61	11.6	12.4	17.3	15.0	140
100	122	136	26.0	27.7	33.5	30.0	216	45	60	12.9	13.8	17.3	15.0	140
110	120	135	28.5	30.3	33.5	37.0	216	-	59	-	15.2	17.3	18.5	140
120	117	134	31.1	33.0	41.5	37.0	237	-	58	-	16.5	17.3	18.5	140
TFS480/	Q _{Th} ¹⁾ 201.7		-		-		-	Q _{Th} ¹⁾ 100.8		-		-		-
10	192	197	4.2	4.9	6.3	7.5	82	91	96	2.0	2.1	2.55	3.0	68
20	188	194	7.5	8.5	12.6	11.0	115	87	94	3.7	3.9	4.55	5.5	72
30	184	192	10.9	12.1	17.3	15.0	124	84	91	5.3	5.7	6.3	7.5	103
40	181	190	14.2	15.6	17.3	18.5	124	80	89	7.0	7.5	8.6	11.0	103
50	178	188	17.6	19.2	21.3	22.0	134	77	88	8.7	9.3	12.6	11.0	123
60	175	187	21.0	22.8	25.3	30.0	162	74	86	10.4	11.1	12.6	15.0	123
70	172	185	24.3	26.4	33.5	30.0	216	71	84	12.1	12.9	17.3	15.0	140
80	169	183	27.7	30.0	33.5	37.0	216	68	83	13.7	14.7	17.3	15.0	140
90	166	182	31.1	33.6	41.5	37.0	237	65	81	15.4	16.5	17.3	18.5	140
100	164	181	34.4	37.1	41.5	45.0	237	62	80	17.1	18.3	21.3	18.5	174
110	161	180	37.8	40.7	41.5	45.0	237	-	79	-	20.1	21.3	22.0	174
120	158	179	41.1	44.3	51.0	45.0	358	-	78	-	21.9	25.3	22.0	182
TFS496/	Q _{Th} ¹⁾ 242		-		-		-	Q _{Th} ¹⁾ 121		-		-		-
10	231	235	4.8	5.6	8.6	7.5	96	110	114	2.3	2.7	3.45	3.7	68
20	226	233	8.9	9.9	12.6	11.0	115	105	112	4.3	4.8	6.3	5.5	103
30	222	231	12.9	14.2	17.3	18.5	124	101	110	6.3	7.0	8.6	7.5	103
40	218	229	16.9	18.5	21.3	22.0	134	97	108	8.4	9.1	12.6	11.0	123
50	214	227	21.0	22.8	25.3	30.0	162	93	106	10.4	11.3	12.6	15.0	123
60	211	225	25.0	27.1	33.5	30.0	216	90	104	12.4	13.5	17.3	15.0	140
70	207	224	29.0	31.4	33.5	37.0	216	86	103	14.4	15.6	17.3	18.5	140
80	204	222	33.1	35.7	41.5	37.0	237	83	101	16.4	17.8	21.3	18.5	174
90	201	220	37.1	40.0	41.5	45.0	237	79	99	18.4	19.9	21.3	22.0	174
100	198	219	41.1	44.3	51.0	55.0	358	76	98	20.5	22.1	25.3	22.0	182
110	195	217	45.2	48.6	51.0	55.0	358	-	96	-	24.3	25.3	30.0	182
120	191	215	49.2	52.9	62.0	55.0	433	-	94	-	26.4	34.5	30.0	232

1) Q_{Th} : 理论流量
黏度 > 20 mm²/s 更大功率消耗。

特性和尺寸

TFS4, FFS4

60 Hz

安装孔形式

TFS3 / TFS4

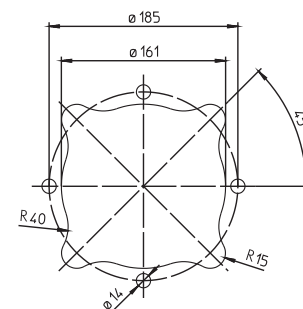
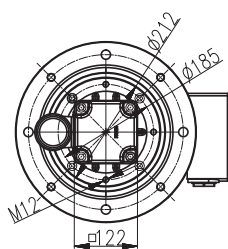

所有角落
必须排除!
根据
ISO 2768-m

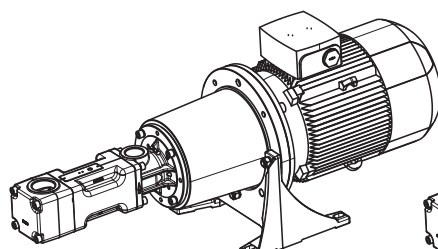
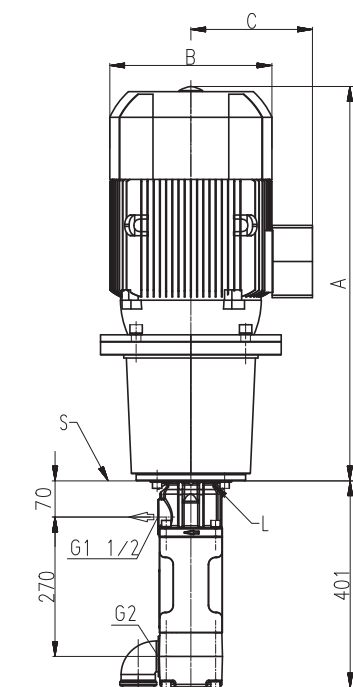

< 45kW

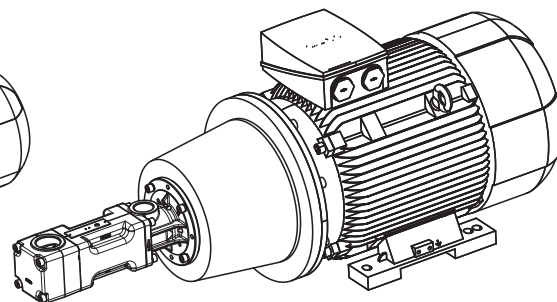

≥ 45kW

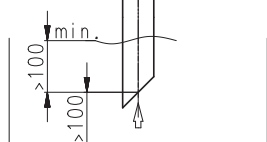

L = 泄漏孔
S = 安装板, 请参考
去除安装孔

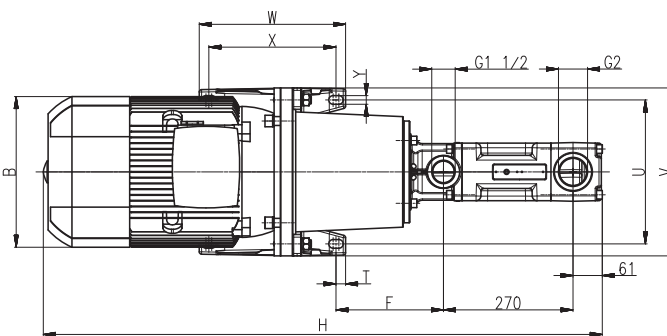
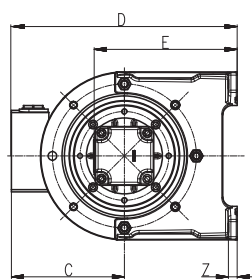

功率 2极 kW	功率 4极 kW	A	B	C	D	E	F	H	T	U	V	W	X	Y	Z
		mm	mm	mm	mm	mm	mm	mm	mm	mm	mm	mm	mm	mm	mm
-	2.2 / 2.55 / 3.0 / 3.45	568	198	166	321	218	188	969	22.5	215	250	230	185	14	15
4.55	3.7 / 4.55	551	222	177	332	218	188	952	22.5	215	250	230	185	14	15
5.5 / 6.3	-	609	262	202	387	248	199	1010	22.5	265	300	270	225	14	18
7.5 / 8.6	5.5 / 6.3	659	262	202	387	248	199	1060	22.5	265	300	270	225	14	18
-	7.5 / 8.6	668	262	202	387	248	199	1069	22.5	265	300	270	225	14	18
11.0 / 12.6 / 15.0 / 17.3	11.0 / 12.6	764	314	237	472	298	224	1165	20	300	350	305	265	18	18
18.5 / 21.3	15.0 / 17.3	824	314	237	472	298	224	1225	20	300	350	305	265	18	18
-	18.5 / 21.3	828	356	286	521	298	224	1229	20	300	350	305	265	18	18
22.0 / 25.3	-	824	356	286	521	298	224	1225	20	300	350	305	265	18	18
-	22.0 / 25.3	858	356	286	521	298	224	1259	20	300	350	305	265	18	18
30.0 / 33.5	-	881	396	315	575	323	214	1282	25	350	400	350	300	18	20
37.0 / 41.5	30.0 / 34.5	906	396	315	575	323	214	1307	25	350	400	350	300	18	20
45.0 / 51.0	-	984	449	338	563	288	495	1385	25	356	436	361	311	19	34
55.0 / 62.0	-	1056	497	410	660	313	547	1457	30	406	490	409	349	24	40

TFS5, FFS5

螺杆

60 Hz

最大压力	2 极电机 转速 3500 RPM							4 极电机 转速 1750 RPM						
	流量		功率消耗		电机		重量	流量		功率消耗		电机		重量
	1 mm ² /s	20 mm ² /s	1 mm ² /s	20 mm ² /s	IE3	NEMA		IE3	1 mm ² /s	20 mm ² /s	1 mm ² /s	20 mm ² /s	IE3	
型号 / bar	l/min	l/min	kW	kW	kW	kW	kg	l/min	l/min	kW	kW	kW	kW	kg
TFS574/	Q _{Th} ¹⁾ 291.6		-	-	-	-	-	Q _{Th} ¹⁾ 145.8		-	-	-	-	-
10	280	285	6.2	7.0	8.6	11.0	123	134	139	2.9	3.4	4.55	5.5	99
20	276	283	11.0	12.1	17.3	15.0	151	130	137	5.4	6.0	8.6	7.5	130
30	272	281	15.9	17.2	21.3	22.0	161	126	135	7.8	8.5	12.6	11.0	150
40	269	279	20.7	22.2	25.3	30.0	189	123	134	10.2	11.1	12.6	15.0	150
50	266	278	25.6	27.3	33.5	30.0	243	120	132	12.6	13.7	17.3	15.0	167
60	262	276	30.5	32.4	33.5	37.0	243	117	130	15.1	16.2	17.3	18.5	167
70	260	274	35.3	37.5	41.5	45.0	264	114	129	17.5	18.8	21.3	22.0	201
80	257	273	40.2	42.6	51.0	45.0	385	111	127	19.9	21.4	25.3	22.0	209
90	254	271	45.0	47.7	51.0	55.0	385	108	126	22.3	23.9	25.3	30.0	209
100	252	270	49.9	52.7	62.0	55.0	460	105	124	24.8	26.5	34.5	30.0	259
110	249	269	54.7	57.8	62.0	75.0	460	-	123	-	29.1	34.5	30.0	259
120	247	267	59.6	62.9	84.0	75.0	585	-	122	-	31.6	34.5	37.0	259
TFS5100/	Q _{Th} ¹⁾ 394.1		-	-	-	-	-	Q _{Th} ¹⁾ 197		-	-	-	-	-
10	378	386	7.9	8.7	12.6	11.0	142	181	189	3.8	4.3	6.3	5.5	130
20	374	383	14.4	15.6	21.3	18.5	161	177	186	7.1	7.8	8.6	11.0	130
30	370	381	21.0	22.6	25.3	30.0	189	173	184	10.4	11.3	12.6	15.0	150
40	366	379	27.6	29.5	33.5	37.0	243	169	182	13.6	14.8	17.3	18.5	167
50	362	377	34.1	36.4	41.5	45.0	264	165	180	16.9	18.3	21.3	22.0	201
60	358	375	40.7	43.4	51.0	55.0	385	161	178	20.2	21.8	25.3	22.0	209
70	355	373	47.3	50.3	62.0	55.0	460	158	176	23.5	25.3	34.5	30.0	259
80	351	371	53.8	57.3	62.0	75.0	460	154	174	26.8	28.8	34.5	30.0	259
90	348	369	60.4	64.2	84.0	75.0	585	150	172	30.1	32.3	34.5	37.0	259
100	345	368	67.0	71.1	84.0	75.0	585	147	171	33.3	35.8	42.5	37.0	355
110	342	366	73.5	78.1	84.0	90.0	585	-	169	-	39.3	42.5	45.0	355
120	338	365	80.1	85.0	101.0	90.0	665	-	168	-	42.8	52.0	45.0	390

¹⁾ Q_{Th} : 理论流量

黏度 > 20 mm²/s 更大功率消耗。

特性和尺寸

TFS5, FFS5

60 Hz

安装孔形式

TFS5

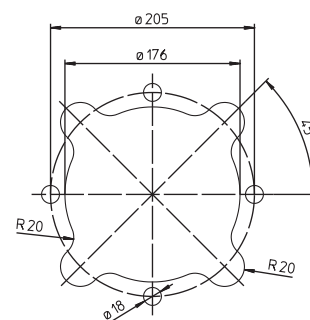

所有角落
必须排除!
根据
ISO 2768-m

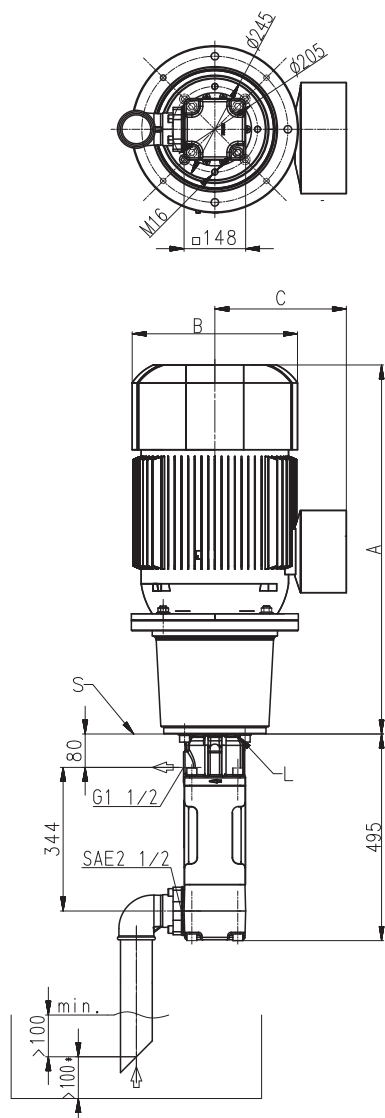

L = 泄漏孔
S = 安装板, 请参考
去除安装孔

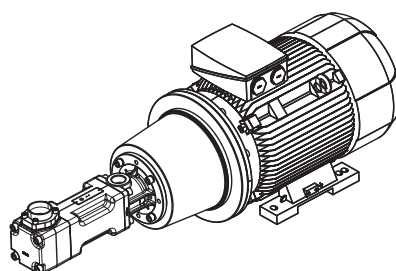

< 45kW

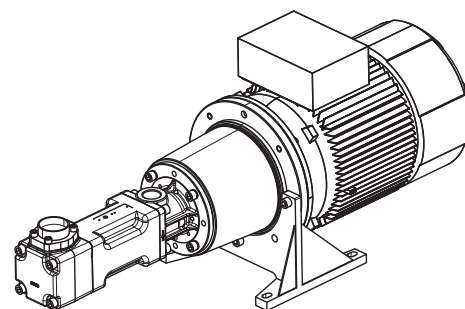

≥ 45kW

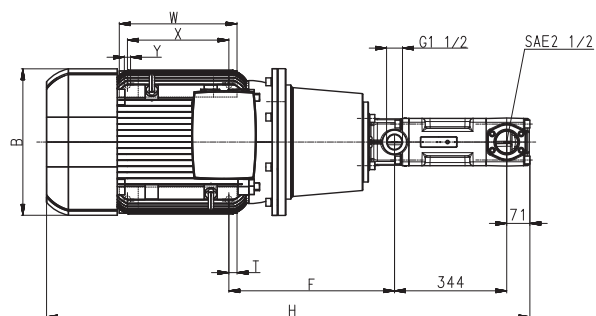
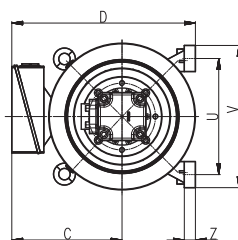

功率 2极 kW	功率 4极 kW	A	B	C	D	F	H	T	U	V	W	X	Y	Z
		mm	mm	mm	mm	mm	mm	mm	mm	mm	mm	mm	mm	mm
-	4.55	581	222	177	332	228	1076	22.5	215	250	230	185	14	15
8.6	5.5 / 6.3	672	262	202	387	222	1167	22.5	265	300	270	225	14	18
-	7.5 / 8.6	681	262	202	387	222	1176	22.5	265	300	270	225	14	18
11.0 / 12.6 / 15.0 / 17.3	11.0 / 12.6	767	314	237	472	237	1262	20	300	350	305	265	18	18
18.5 / 21.3	15.0 / 17.3	827	314	237	472	237	1322	20	300	350	305	265	18	18
-	18.5 / 21.3	831	356	286	521	237	1326	20	300	350	305	265	18	18
22.0 / 25.3	-	827	356	286	521	237	1322	20	300	350	305	265	18	18
-	22.0 / 25.3	861	356	286	521	237	1356	20	300	350	305	265	18	18
30.0 / 33.5	-	884	396	315	575	227	1379	25	350	400	350	300	18	20
37.0 / 41.5	30.0 / 34.5	909	396	315	575	227	1404	25	350	400	350	300	18	20
-	37.0 / 42.5	929	449	338	633	223	1422	25	400	450	385	335	18	20
45.0 / 51.0	45.0 / 52.0	987	449	338	563	508	1482	25	356	436	361	311	19	34
55.0 / 62.0	-	1059	497	410	660	560	1554	30	406	490	409	349	24	40
75.0 / 84.0	-	1132	551	433	713	582	1627	55.5	457	540	479	368	24	40
90.0 / 101.0	-	1243	551	433	713	582	1738	30	457	540	479	419	24	40

最大 压力	2 极电机 转速 3500 RPM							4 极电机 转速 1750 RPM						
	流量		功率消耗		电机		重量	流量		功率消耗		电机		重量
	1 mm ² /s	20 mm ² /s	1 mm ² /s	20 mm ² /s	IE3	NEMA		IE3	1 mm ² /s	20 mm ² /s	1 mm ² /s	20 mm ² /s	IE3	
型号 / bar	l/min	l/min	kW	kW	kW	kW	kg	l/min	l/min	kW	kW	kW	kW	kg
TFS5120/	Q _{Th} ¹⁾ 472.9		-	-	-	-	-	Q _{Th} ¹⁾ 236.4		-	-	-	-	-
10	453	463	9.2	10.0	12.6	15.0	142	217	227	4.4	5.0	6.3	7.5	130
20	447	460	17.1	18.4	21.3	22.0	161	211	223	8.4	9.2	12.6	11.0	150
30	442	457	24.9	26.7	33.5	30.0	243	205	220	12.3	13.4	17.3	15.0	167
40	436	454	32.8	35.1	41.5	37.0	264	200	218	16.3	17.6	21.3	18.5	201
50	431	452	40.7	43.5	51.0	55.0	385	195	215	20.2	21.8	25.3	22.0	209
60	426	449	48.6	51.9	62.0	55.0	460	190	213	24.1	26.1	34.5	30.0	259
70	421	447	56.5	60.2	62.0	75.0	460	185	210	28.1	30.3	34.5	37.0	259
80	417	445	64.3	68.6	84.0	75.0	585	180	208	32.0	34.5	42.5	37.0	355
90	412	443	72.2	77.0	84.0	90.0	585	175	206	36.0	38.7	42.5	45.0	355
100	408	441	80.1	85.4	101.0	90.0	665	170	205	39.9	42.9	52.0	45.0	390
110	403	440	88.0	93.7	101.0	110.0	665	-	203	-	47.1	52.0	55.0	390
120	399	438	95.8	102.1	123.0	110.0	825	-	202	-	51.3	63.0	55.0	495
TFS5130/	Q _{Th} ¹⁾ 512.3		-	-	-	-	-	Q _{Th} ¹⁾ 256.1		-	-	-	-	-
10	491	500	9.8	11.7	17.3	15.0	151	235	243	4.8	5.4	6.3	7.5	130
20	484	495	18.4	20.3	25.3	30.0	189	228	239	9.0	9.8	12.6	11.0	150
30	477	490	26.9	29.0	33.5	37.0	243	221	234	13.3	14.2	17.3	15.0	167
40	471	486	35.5	37.6	41.5	45.0	264	215	230	17.6	18.6	21.3	22.0	201
50	465	482	44.0	46.2	51.0	55.0	385	209	225	21.8	23.0	25.3	30.0	209
60	459	477	52.5	54.8	62.0	75.0	460	203	221	26.1	27.3	34.5	30.0	259
70	454	474	61.1	63.5	84.0	75.0	585	198	217	30.4	31.7	34.5	37.0	259
80	449	470	69.6	72.1	84.0	75.0	585	193	214	34.7	36.1	42.5	37.0	355
90	444	466	78.1	80.7	84.0	90.0	585	187	210	38.9	40.5	42.5	45.0	355
100	440	463	86.7	89.3	101.0	90.0	665	182	207	43.2	44.9	52.0	55.0	390
110	-	460	-	98.0	123.0	110.0	825	-	204	-	49.3	52.0	55.0	390
120	-	457	-	106.6	123.0	110.0	825	-	201	-	53.7	63.0	55.0	495

¹⁾ Q_{Th} : 理论流量

黏度 > 20 mm²/s 更大功率消耗。

特性和尺寸

TFS5, FFS5

60 Hz

安装孔形式

TFS5

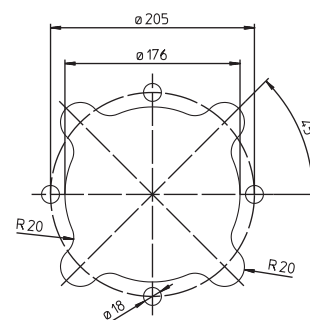

所有角落
必须排除!
根据
ISO 2768-m

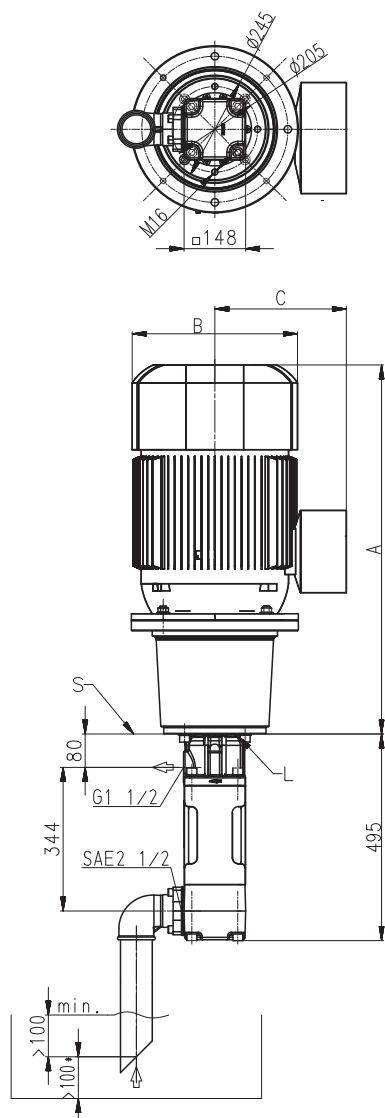

L = 泄漏孔
S = 安装板, 请参考
去除安装孔

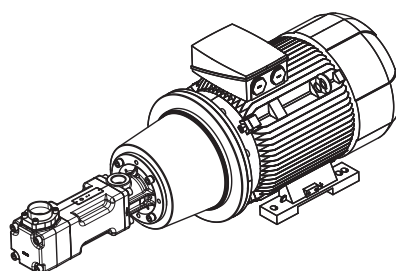

< 45kW

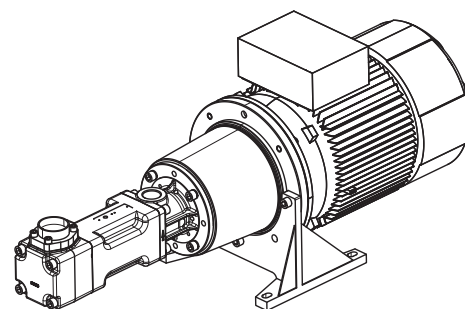

≥ 45kW

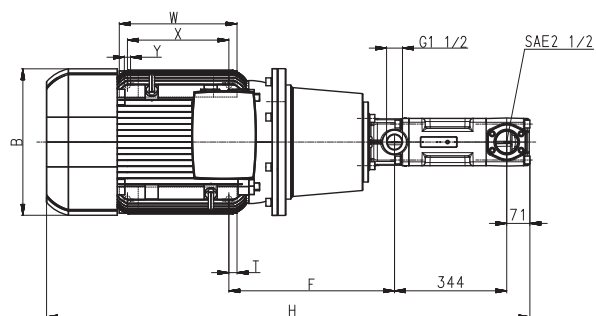
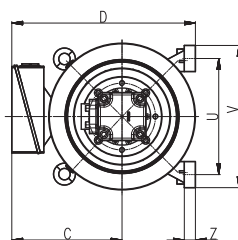

功率 2极 kW	功率 4极 kW	A	B	C	D	F	H	T	U	V	W	X	Y	Z
		mm	mm	mm	mm	mm	mm	mm	mm	mm	mm	mm	mm	mm
-	6.3	672	262	202	387	222	1167	22.5	265	300	270	225	14	18
-	7.5	681	262	202	387	222	1176	22.5	265	300	270	225	14	18
12.6 / 15.0 / 17.3	11.0 / 12.6	767	314	237	472	237	1262	20	300	350	305	265	18	18
21.3	15.0 / 17.3	827	314	237	472	237	1322	20	300	350	305	265	18	18
-	18.5 / 21.3	831	356	286	521	237	1326	20	300	350	305	265	18	18
22.0 / 25.3	-	827	356	286	521	237	1322	20	300	350	305	265	18	18
-	22.0 / 25.3	861	356	286	521	237	1356	20	300	350	305	265	18	18
30.0 / 33.5	-	884	396	315	575	227	1379	25	350	400	350	300	18	20
37.0 / 41.5	30.0 / 34.5	909	396	315	575	227	1404	25	350	400	350	300	18	20
-	37.0 / 42.5	929	449	338	633	223	1422	25	400	450	385	335	18	20
45.0 / 51.0	45.0 / 52.0	987	449	338	563	508	1482	25	356	436	361	311	19	34
55.0 / 62.0	55.0 / 63.0	1059	497	410	660	560	1554	30	406	490	409	349	24	40
75.0 / 84.0	-	1132	551	433	713	582	1627	55.5	457	540	479	368	24	40
90.0 / 101.0	-	1243	551	433	713	582	1738	30	457	540	479	419	24	40
110.0 / 123.0	-	1239	616	515	830	623	1734	35	508	610	527	406	28	50

TFS6, FFS6

螺杆



2 极电机 转速 3500 RPM								4 极电机 转速 1750 RPM						
最大 压力	流量		功率消耗		电机		重量	流量		功率消耗		电机		重量
	1 mm ² /s l/min	20 mm ² /s l/min	1 mm ² /s kW	20 mm ² /s kW	IE3 kW	NEMA kW		IE3 kg	1 mm ² /s l/min	20 mm ² /s l/min	1 mm ² /s kW	20 mm ² /s kW	IE3 kW	
TFS690/	Q_{Th}¹⁾ 554		-	-	-	-	-	Q_{Th}¹⁾ 277		-	-	-	-	-
10	540	545	11.6	13.3	17.3	18.5	199	263	268	5.6	6.2	8.6	7.5	178
20	532	540	20.9	22.6	33.5	30.0	291	255	263	10.2	10.8	12.6	15.0	198
30	524	535	30.1	31.8	41.5	37.0	312	247	258	14.9	15.5	17.3	18.5	215
40	516	531	39.3	41.0	51.0	45.0	433	239	254	19.5	20.1	25.3	22.0	257
50	509	527	48.6	50.3	62.0	55.0	508	232	250	24.1	24.7	34.5	30.0	307
60	502	523	57.8	59.5	62.0	75.0	508	225	246	28.7	29.3	34.5	37.0	307
70	496	519	67.0	68.7	84.0	75.0	633	219	242	33.3	33.9	42.5	37.0	403
80	490	515	76.3	78.0	84.0	90.0	633	213	238	37.9	38.5	42.5	45.0	403
TFS6120/	Q_{Th}¹⁾ 739		-	-	-	-	-	Q_{Th}¹⁾ 369		-	-	-	-	-
10	720	726	14.7	16.4	21.3	22.0	209	351	357	7.2	7.8	12.6	11.0	198
20	710	721	27.0	28.7	33.5	37.0	291	341	351	13.3	13.9	17.3	18.5	215
30	701	715	39.3	41.0	51.0	45.0	433	331	346	19.5	20.1	21.3	22.0	249
40	692	710	51.6	53.3	62.0	75.0	508	322	340	25.6	26.2	34.5	30.0	307
50	683	704	64.0	65.7	84.0	75.0	633	314	335	31.8	32.4	34.5	37.0	307
60	676	699	76.3	78.0	84.0	90.0	633	306	330	37.9	38.5	42.5	45.0	403
70	668	695	88.6	90.3	101.0	110.0	713	299	325	44.1	44.7	52.0	55.0	438
80	659	689	101.0	103.0	123.0	110.0	872	290	320	50.2	50.8	63.0	55.0	543
TFS6145/	Q_{Th}¹⁾ 893		-	-	-	-	-	Q_{Th}¹⁾ 446		-	-	-	-	-
10	870	878	17.3	19.0	25.3	30.0	237	424	432	8.4	9.0	12.6	11.0	198
20	857	868	32.2	33.9	41.5	45.0	312	411	422	15.9	16.5	21.3	18.5	249
30	845	859	47.0	48.7	62.0	55.0	508	398	413	23.3	23.9	34.5	30.0	307
40	833	851	61.9	63.6	84.0	75.0	633	386	405	30.8	31.4	34.5	37.0	307
50	822	844	76.8	78.5	84.0	90.0	633	375	397	38.2	38.8	42.5	45.0	403
60	811	837	91.7	93.4	101.0	110.0	713	365	391	45.6	46.2	52.0	55.0	438
70	799	829	106.6	108.3	123.0	110.0	872	353	382	53.1	53.7	63.0	55.0	543

¹⁾ Q_{Th}: 理论流量

黏度 > 20 mm²/s 更大功率消耗。

所有 6 系列螺杆泵的工作流量在 800 l/min 或以上，必须配备进给泵，提供流体至少 1bar 的压力到泵的入口。

特性和尺寸

TFS6, FFS6

60 Hz

安装孔形式

TFS6

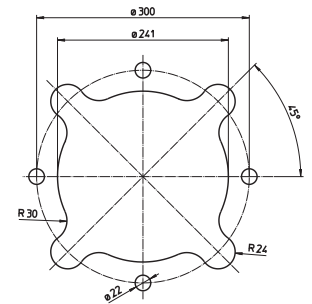
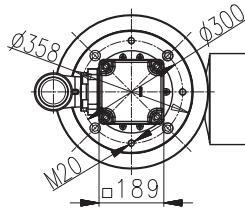

所有角落
必须排除!
根据
ISO 2768-m

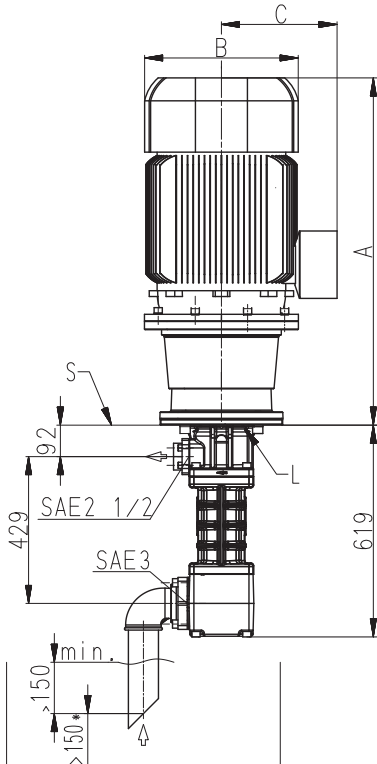

L = 泄漏孔
S = 安装板, 请参考
去除安装孔

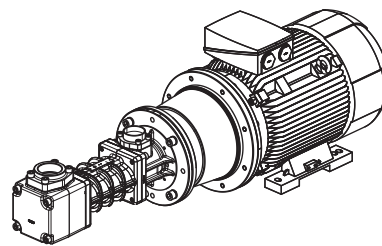

< 45kW

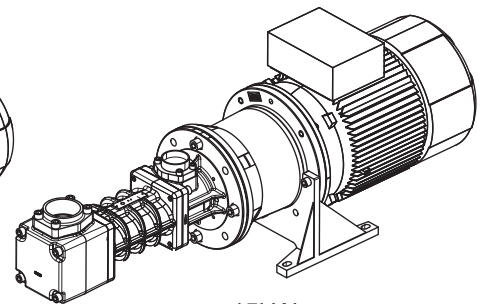

≥ 45kW

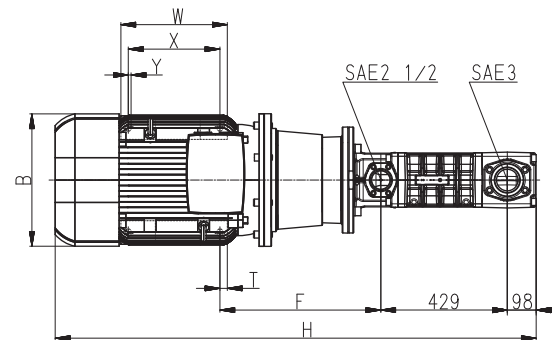
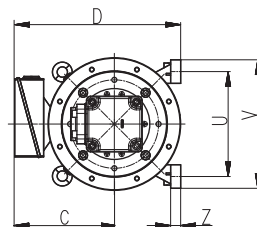

功率 2极 kW	功率 4极 kW	A	B	C	D	F	H	T	U	V	W	X	Y	Z
		mm	mm	mm	mm	mm	mm	mm	mm	mm	mm	mm	mm	mm
-	7.5 / 8.6	723	262	202	387	242	1342	22.5	265	300	270	225	14	18
-	11.0 / 12.6	795	314	237	472	242	1414	20	300	350	305	265	18	18
-	15.0 / 17.3	855	314	237	472	265	1474	20	300	350	305	265	18	18
17.3	-	795	314	237	497	242	1414	25	350	400	350	300	18	20
18.5 / 21.3	-	855	314	237	497	242	1474	25	350	400	350	300	18	20
-	18.5 / 21.3	859	356	286	521	265	1478	20	300	350	305	265	18	18
22.0 / 25.3	-	855	356	286	546	242	1474	25	350	400	350	300	18	20
-	22.0 / 25.3	889	356	286	521	397	1508	20	300	350	305	265	18	18
30.0 / 33.5	-	910	396	315	575	265	1529	25	350	400	350	300	18	20
-	30.0 / 34.5	935	396	315	575	417	1554	25	350	400	350	300	18	20
37.0 / 41.5	-	935	396	315	575	265	1554	25	350	400	350	300	18	20
-	37.0 / 42.5	973	449	338	633	432	1592	25	400	450	385	335	18	20
45.0 / 51.0	45.0 / 52.0	1013	449	338	563	546	1632	25	356	436	361	311	19	34
55.0 / 62.0	-	1072	497	410	660	585	1691	30	406	490	409	349	24	40
-	55.0 / 63.0	1087	497	410	660	600	1706	30	406	490	409	349	24	40
75.0	-	1160	551	433	713	622	1779	55.5	457	540	479	368	24	40
84.0 / 90.0 / 101.0	-	1270	551	433	713	622	1889	30	457	540	479	419	24	40
110.0 / 123.0	-	1242	616	515	830	638	1861	60.5	508	610	527	406	28	50

阀

可调节式泄压阀

可调节式泄压阀允许在5-120 bar 范围内任意压力进行调节。

但是为了防止电机过载，最大的工作压力不可超过使用的特定的泵和电机组可允许的最大工作压力。

系统用户必须确保压力决不会超过可允许的最高工作压力（例如，通过使用另一个不可调节式泄压阀设定可允许的最高压力）。

3-HPB 系列

3-HPB 系列是手动调节式泄压阀。

这种泄压阀是气动式，压力控制比例为1:10和1:18.5。

无能量和空气供给时，阀为完全打开或闲置模式。

SPB 系列

SPB 系列泄压阀是电子式泄压阀。

阀需要0 - 10 V 的模拟信号。

控制电压和工作压力的比例是1:10和1:18.5。

无能量和空气供给时，阀为完全打开或闲置模式。

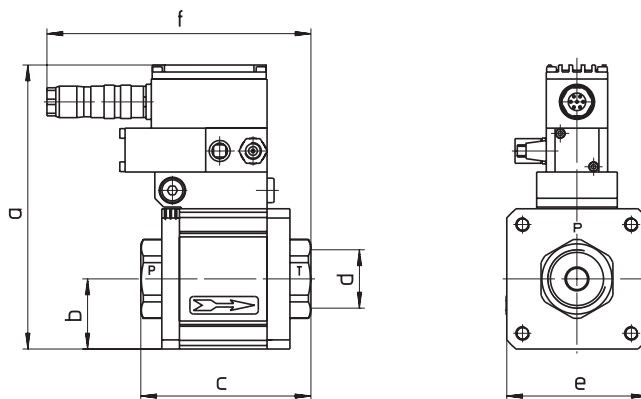
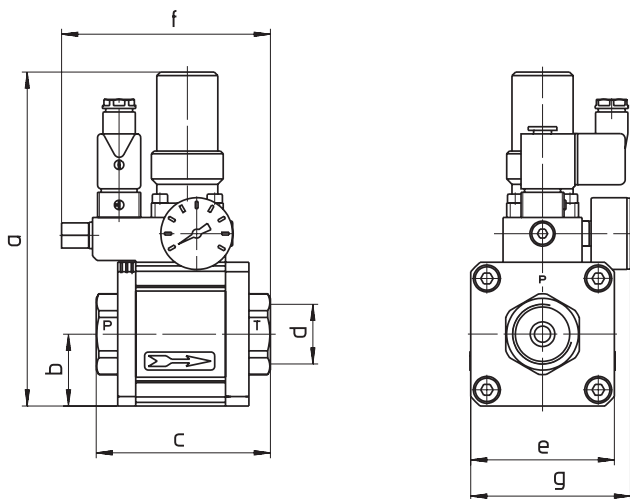

型号索引	压力 p (bar)	流量 Qmax (l/min)
3-HPB-08	10-200	18
3-HPB-S 15	5-64	100
3-HPB-H 15	5-120	100
3-HPB-S 32	5-64	400
3-HPB-H 32	5-120	240
3-HPB-S 50	5-64	800

型号索引	压力 p (bar)	流量 Qmax (l/min)
SPB-08	10-200	18
SPB-S 15	5-64	100
SPB-H 15	5-120	100
SPB-S 32	5-64	400
SPB-H 32	5-120	240
SPB-S 50	5-64	800

型号索引 3-HPB	a mm	b mm	c mm	d mm	e mm	f mm	g mm
08	180	37	138	G ³ / ₈	∅ 74	-	-
S / H 15	186	40	97	G1	□ 80	116.3	89
S / H 32	231	60	160	G1 ¹ / ₂	□ 120	125	109
S 50	251	70	160	G1 ¹ / ₂	□ 140	-	-

型号索引 SPB	a mm	b mm	c mm	d mm	e mm	f mm
08	151	37	138	G ³ / ₈	∅ 74	-
S / H 15	162	40	97	G1	□ 80	150.5
S / H 32	192.5	60	160	G1 ¹ / ₂	□ 120	176.5
S 50	251	70	160	G1 ¹ / ₂	□ 140	-

其他阀请洽询。

3-HPB – 08 | SPB – 08

控制压力图表

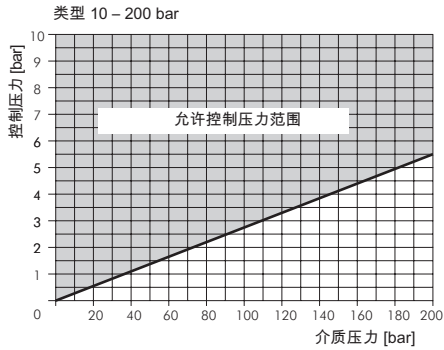

降压再循环模式

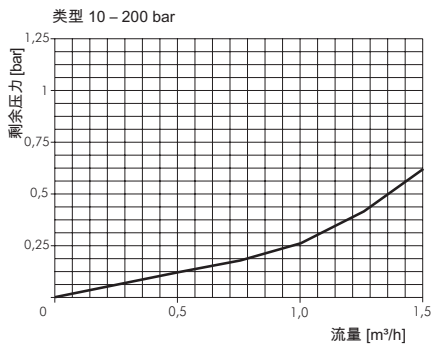

3 – HPB – S 15 | SPB – S 15

控制压力图表

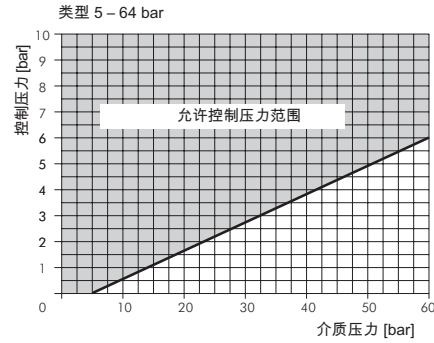

降压再循环模式

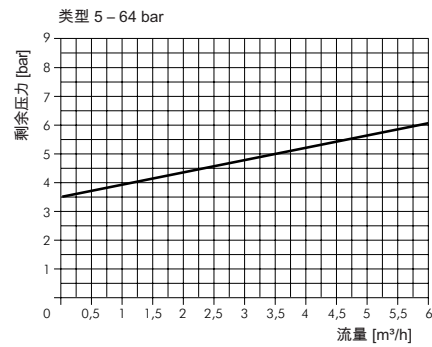

3 – HPB – H 15 | SPB – H 15

控制压力图表

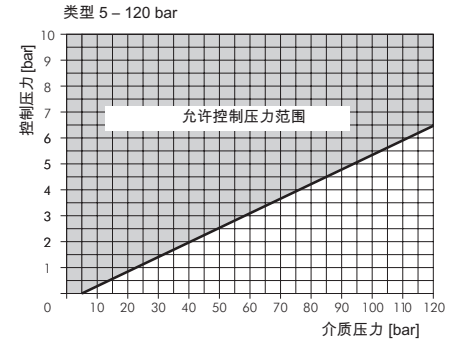

降压再循环模式

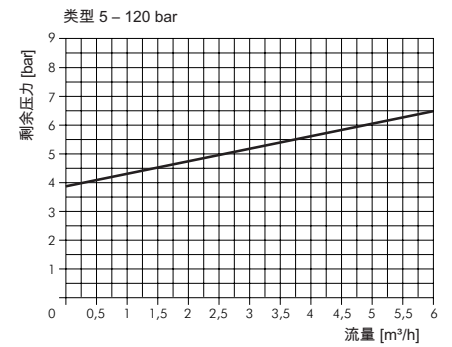

3 – HPB – S 32 | SPB – S 32

控制压力图表

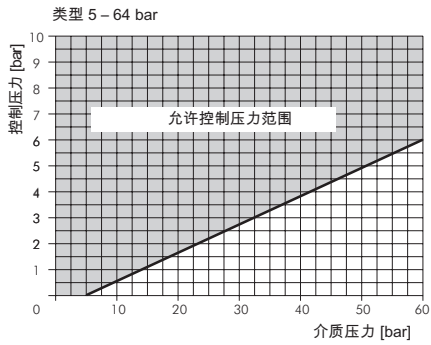

降压再循环模式

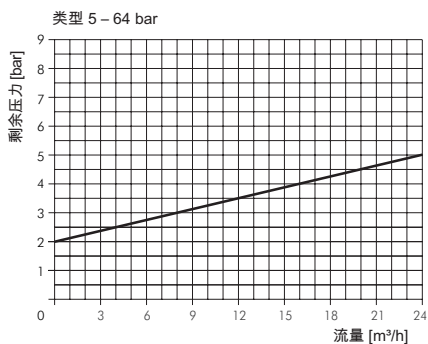

3 – HPB – H 32 | SPB – H 32

控制压力图表

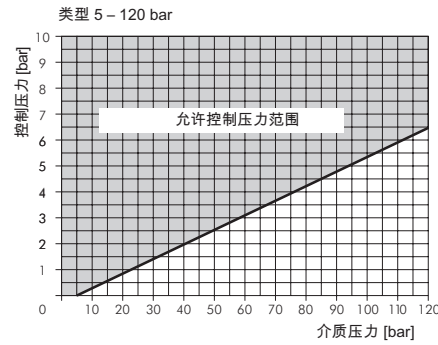

降压再循环模式

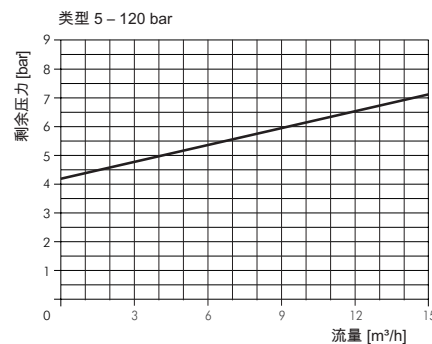

3 – HPB – S 50 | SPB – S 50

控制压力图表

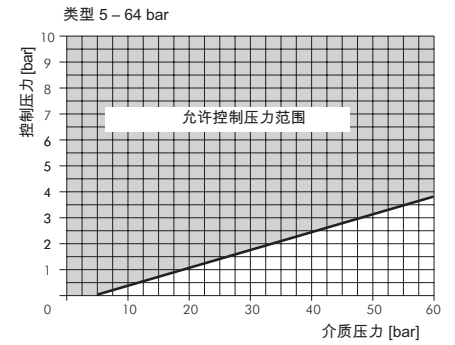

降压再循环模式

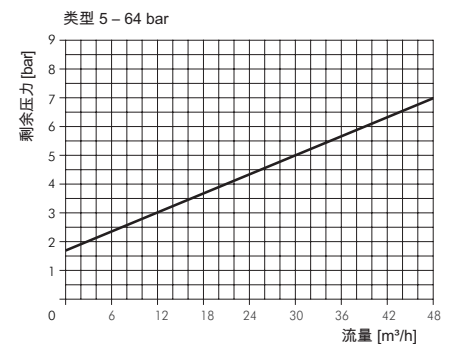

阀

不可调节式泄压阀

螺杆泵是一种计量泵，在安装时总是需要安装一个泄压阀，来保护泵。设定泄压阀为最大工作压力，防止电机过载。一旦压力达到设定最大值，泄压阀会打开，多余的流量会通过阀回到水箱。

为了避免系统中的压力峰值，推荐泄压阀加衬垫以抵抗振动。

BBV / HBV 系列就是这样的泄压阀。他们可在10 bar 增量的情况下使用，由厂家针对特殊的泵和电机组合可允许的最大工作压力而设定。

不可调节式泄压阀 BBV / HBV

不可调解室泄压阀 BBV / HBV 系列在达到预定压力时打开，吸收振动。泄压阀在高于厂家设定的压力10 bar 的情况下打开，多余的流量通过一条单独的旁路流回水箱。

泵的型号	阀的型号	压力 (bar)														
		10	20	30	40	50	60	70	80	90	100	110	120	130	140	150
BFS1, FFS1 BFS232, FFS232	BBV1	●	●	●	●	●	●	●	●	●	●	●	●	●	●	●
BFS2, FFS2	BBV2	●	●	●	●	●	●	●	●	●	●	●	●	●	●	●
BFS1-H, BFS2-H	HBV2	●	●	●	●	●	●	●	●	●	●	●	●	—	—	—
TFS3, FFS3	BBV3	●	●	●	●	●	●	●	●	●	●	●	●	●	●	●
TFS3-H	HBV3	●	●	●	●	●	●	●	●	●	●	●	●	—	—	—

订购号码：例如 BBV 3 / 50

BBV

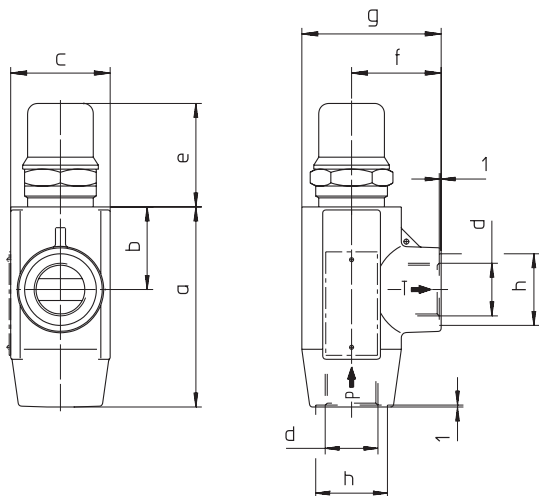

	BBV 1 + 2 mm	BBV 3 mm
a	100.5	130
b	41.5	53
c	50	65
d	G ¾	G1
e	52	81
f	45	49
g	70	81.5
h	36	42

HBV 1+2

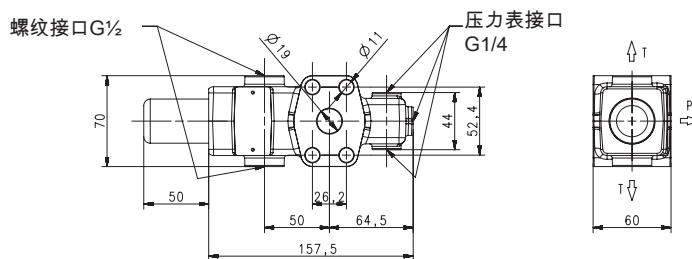

HBV 3

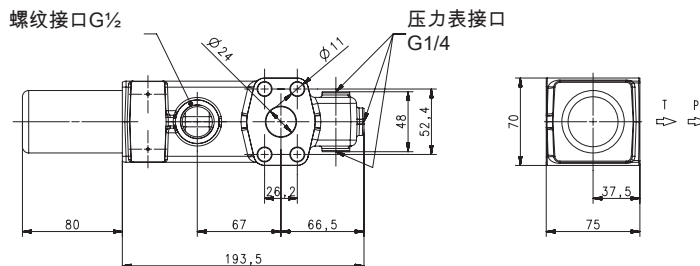

泄压阀的其他性能请洽询。由于受载弹簧的张力范围，实际开启压力可能会偏离阀设定的压力。

BBV: 根据要求可提供上述泄压阀可调节的形式。

系统用户必须确保压力绝不会超过可允许的最高工作压力（例如：通过使用另一个不可调节式泄压阀设定可允许的最高压力）。

压力表/ 吸入端保护 G4 类型

压力表

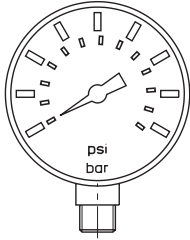

型号索引	压力 p (bar)
M 60	0 – 60
M 100	0 – 100
M 160	0 – 160

G4 类型

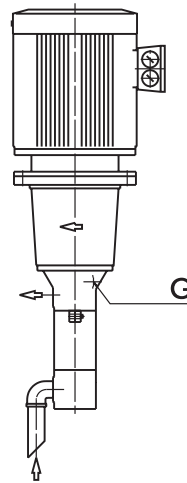

G1/8 BFS/FFS 1, 2
G1/4 TFS/FFS 3, 4, 5

降压渗漏细流回流到水箱

吸入端保护

获得专利保护的吸入保护装置可防止大的颗粒 (和异物) 进入螺杆泵的吸入端。

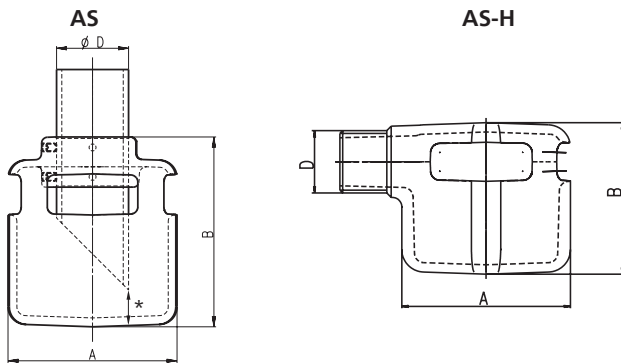

* 最小距离 1/3 D

型号索引	泵的型号	A mm	B mm	Ø D
AS1-2	BFS1, BFS2	90	94	1"
AS3	TFS3	115	129	1½"
AS4	TFS4	150	175	2"
AS5	TFS5	195	190	2½"
AS1-2-H	BFS1, BFS2	90	80	1"
AS3H	TFS3	115	115	G1½
AS4H	TFS4	153	175	G2
AS5H	TFS5	194	190	G2½

SAE 法兰

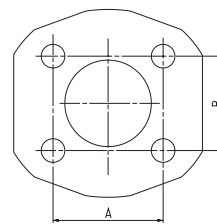

型号索引	泵的型号	A mm	B mm
SAE 2 ½	TFS5, FFS5	88.9	50.8
SAE 3	TFS6, FFS6	120.6	69.8

完整组装的泵的系统

1. **BFS1** 和 **BFS2** 系列，不可调节式泄压阀：
螺杆泵带安装板，一体化连接块和管路的完整安装。
不可调节式泄压阀内置于连接块内。

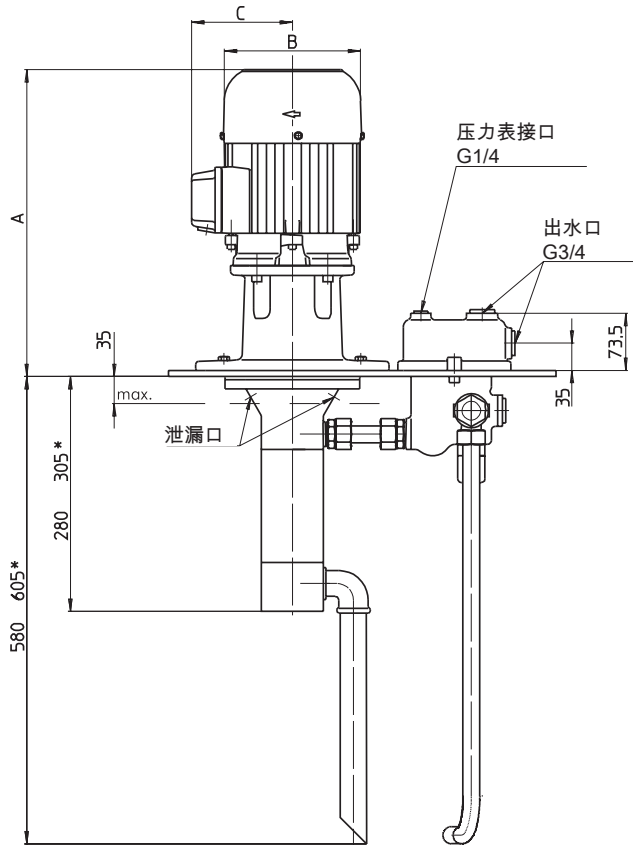

2. **BFS1** 和 **BFS2** 系列，可调节式泄压阀：
螺杆泵带安装板，一体化连接块和管路的完整安装。
不可调节式泄压阀内置于连接块内。
可调节式泄压阀安装在安装板上。

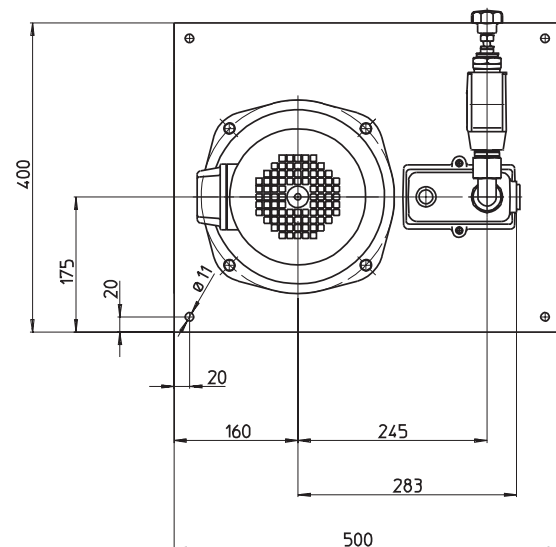
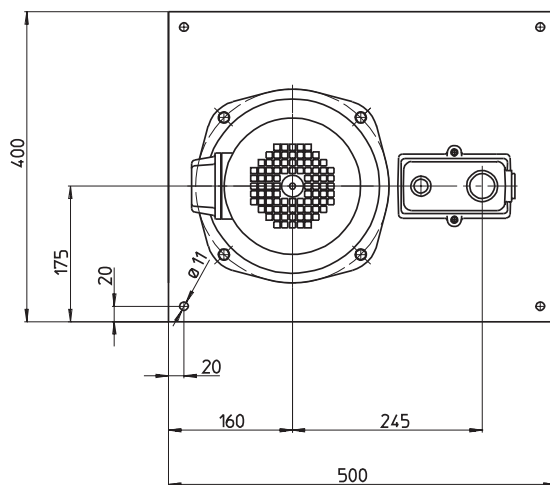
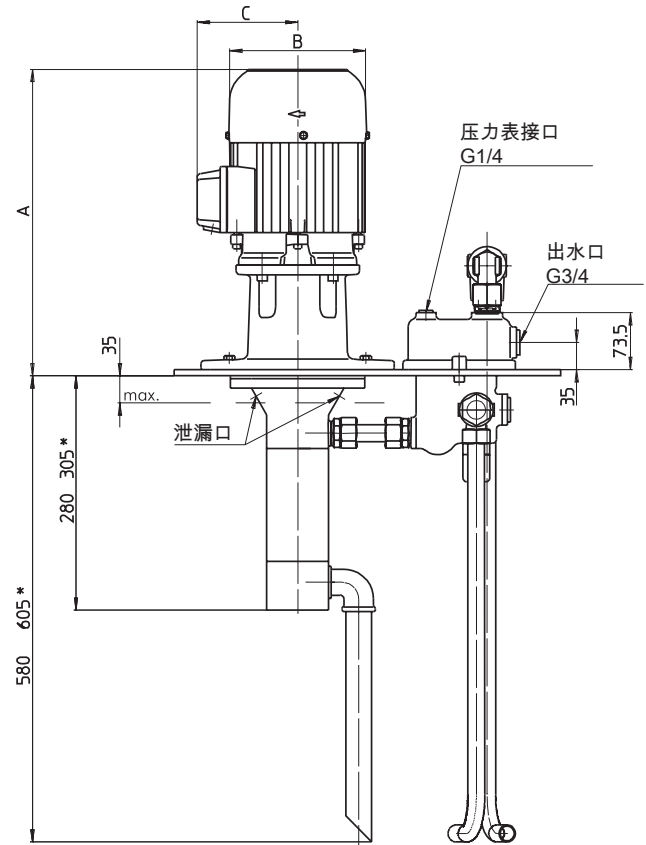

*) BFS2 尺寸
安装板尺寸 A + 8 mm

*) BFS2 尺寸
安装板尺寸 A + 8 mm

完整组装的泵的系统

3. **TFS3 系列，不可调节式泄压阀：**
 螺杆泵带安装板，一体化连接块和管路的完整安装。
 不可调节式泄压阀内置于连接块内。

4. **TFS3 系列，可调节式泄压阀：**
 螺杆泵带安装板，一体化连接块和管路的完整安装。
 不可调节式泄压阀内置于连接块内。
 可调节式泄压阀安装在安装板上。

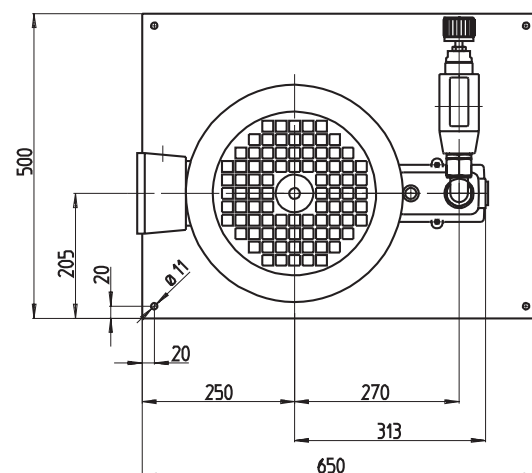
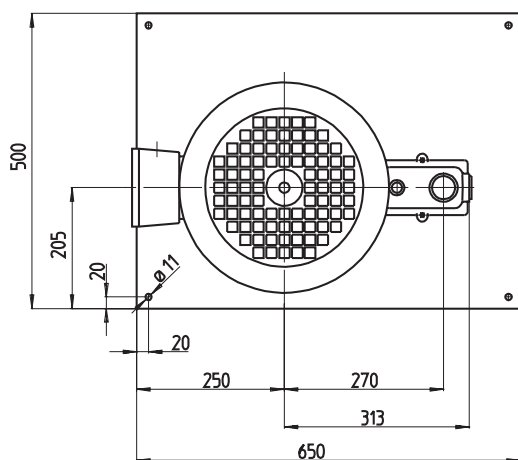
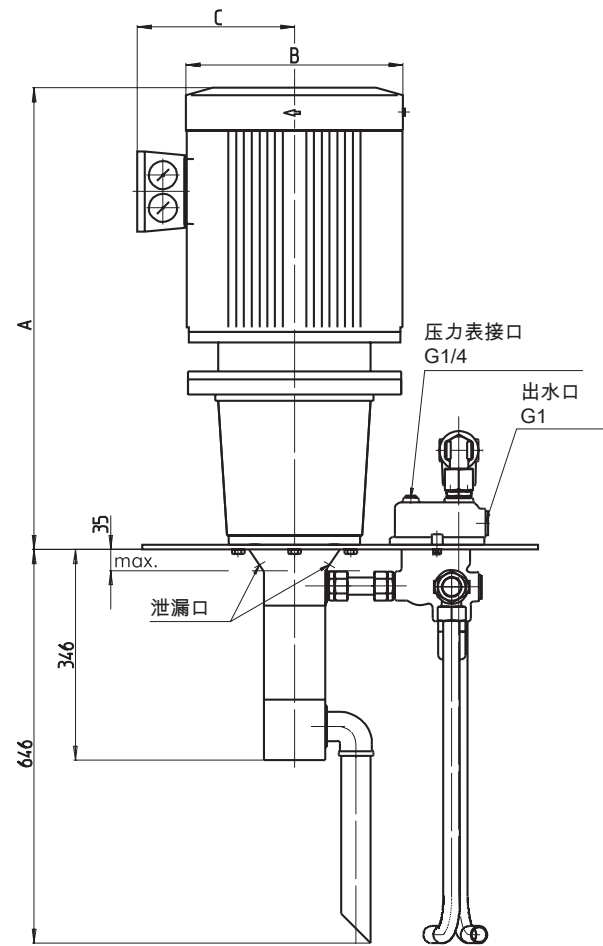
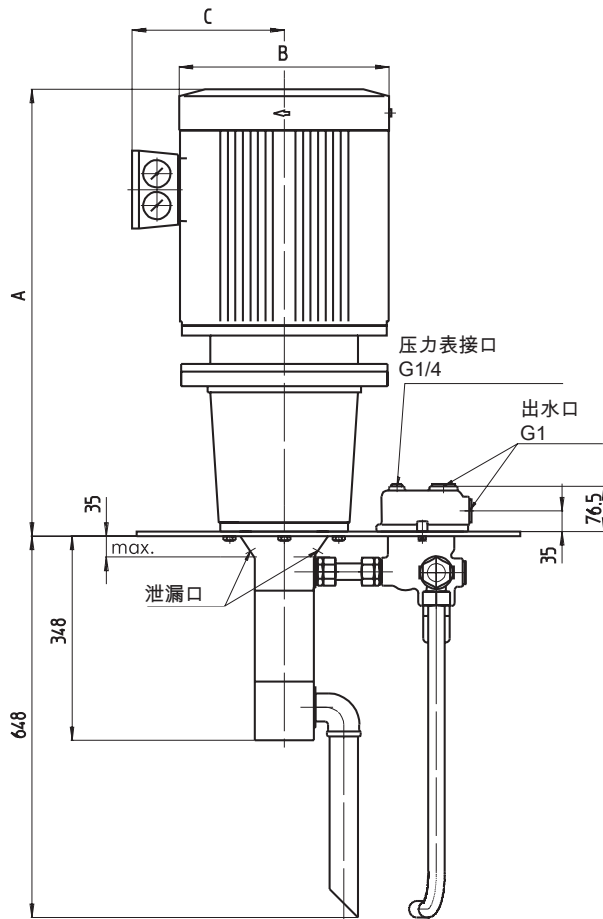

安装板尺寸 A + 8 mm

安装板尺寸 A + 8 mm

完整组装的泵的系统

5. **TFS4 和 TFS5 系列**，可调节式泄压阀（气动工作）：
 螺杆泵带安装板，可调节式泄压阀（气动工作）
 和管路的完整安装。
 可调节式泄压阀安装在安装板上。

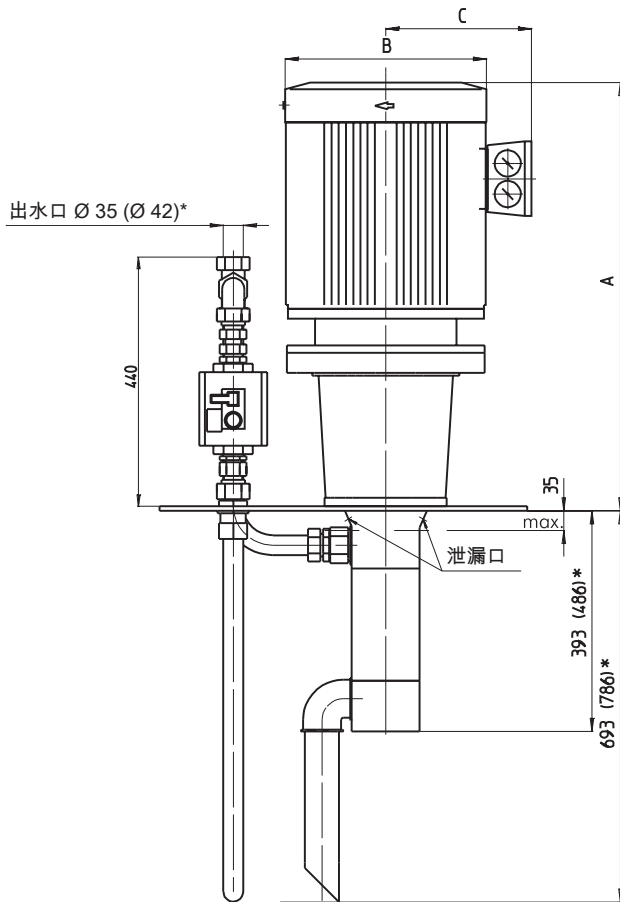

6. **TFS6 系列**，可调节式泄压阀：
 螺杆泵带安装板，可调节式泄压阀（气动工作）
 和管路的完整安装。
 可调节式泄压阀安装在安装板上。

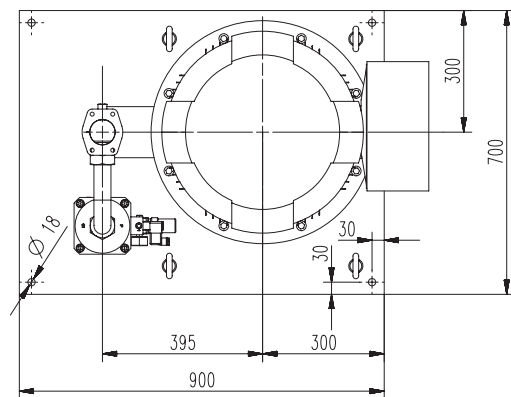
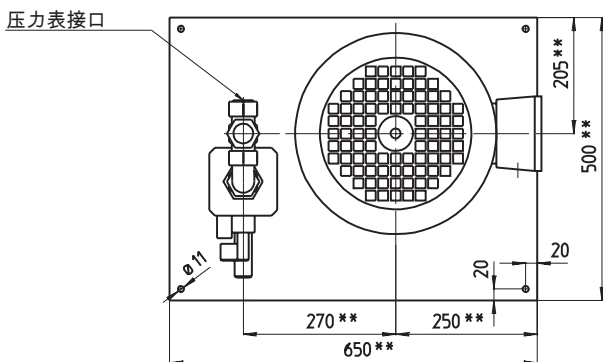
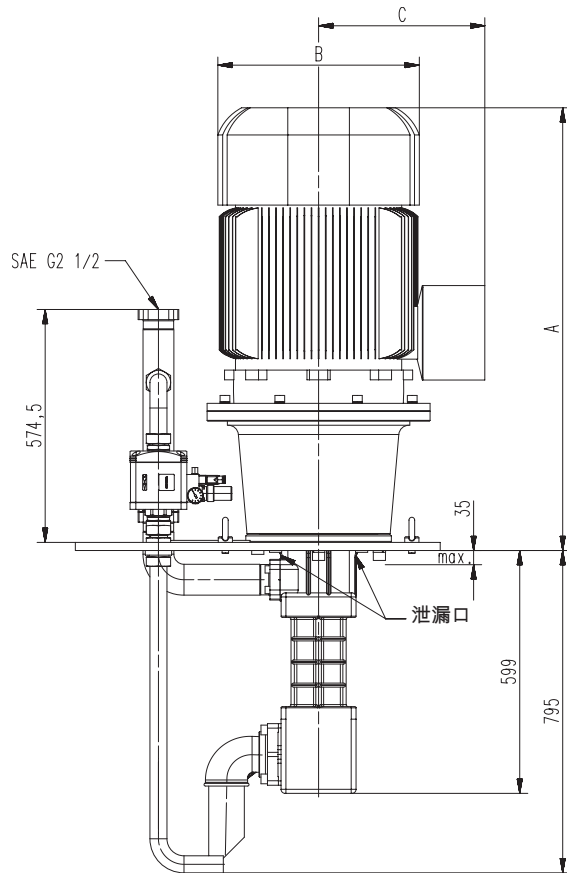

*) TFS5 尺寸
 **) 电机大于 37kW 的尺寸请咨询
 安装板尺寸 A + 12 mm

完整组装的泵的系统

7. **BFS1-H / BFS2-H** 系列，不可调节式泄压阀：
 螺杆泵内置完整安装的连接块。
 不可调节式泄压阀内置于连接块内。

安装孔形式

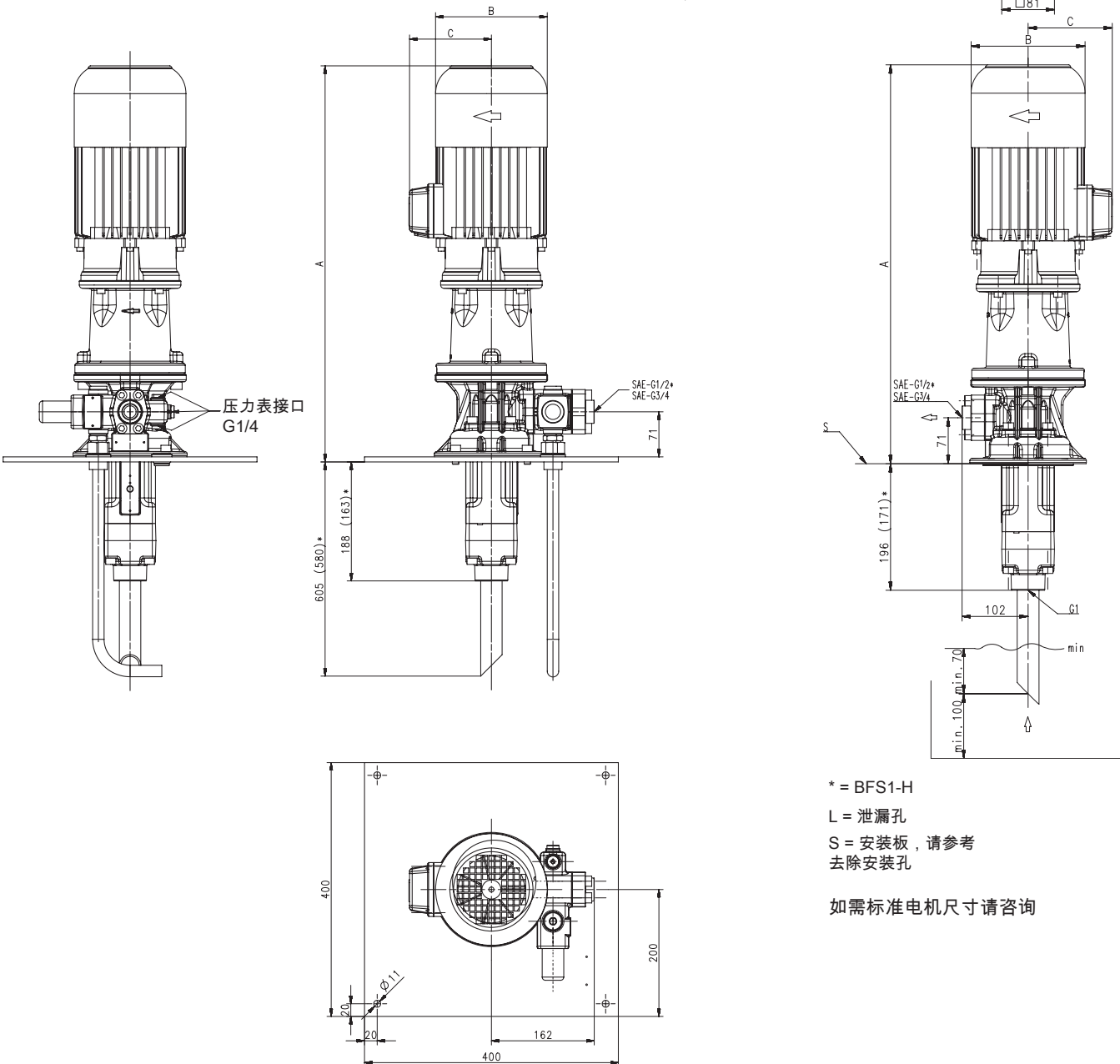
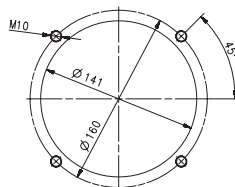

* = BFS1-H
 L = 泄漏孔
 S = 安装板，请参考
 去除安装孔

如需标准电机尺寸请咨询

功率 50 Hz 2 极 kW	BFS1-H			BFS2-H			功率 60 Hz 2 极 kW	BFS1-H			BFS2-H		
	A mm	B mm	C mm	A mm	B mm	C mm		A mm	B mm	C mm	A mm	B mm	C mm
B 1.3 / 1.5	558	176	130	558	176	130	B 1.49 / 1.75	558	176	130	558	176	130
B 1.7	584	176	130	584	176	130	B 2.18 / 2.55 / 2.94	617	176	130	617	176	130
B 1.9 / 2.2 / 2.6	617	176	130	617	176	130	B 3.45 / 3.8 / 4.55	656	218	150	656	218	150
B 3.3 / 4.0	656	218	150	656	218	150	B 5.75 / 6.3	686	218	150	686	218	150
B 5.0 / 5.5	686	218	150	686	218	150	B 8.6	765	258	193	765	258	193
B 7.5	765	258	193	765	258	193	B 10.3				765	258	193
B 9.0				765	258	193	B 12.6 / 15.0				773	310	240
B 11.0 / 13.0				773	310	240							

完整组装的泵的系统

8. TFS3-H 系列，不可调节式泄压阀：
 螺杆泵内置完整安装的连接块。
 不可调节式泄压阀内置于连接块内。

安装孔形式

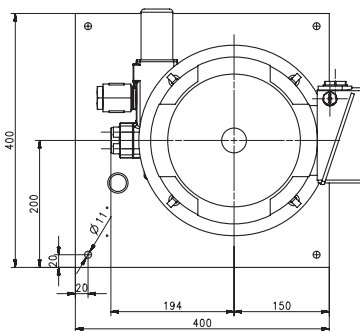
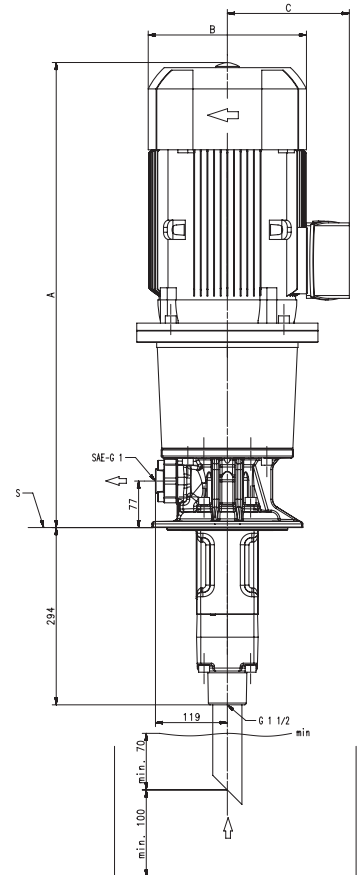
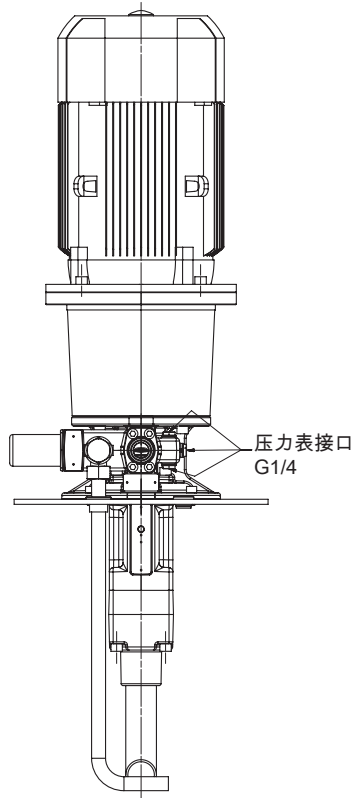
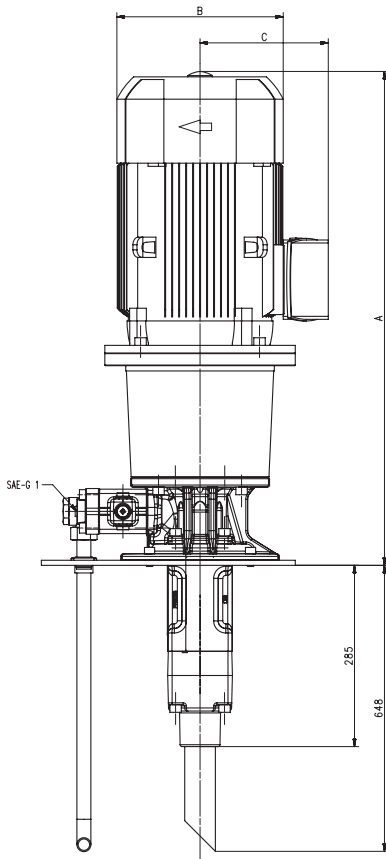
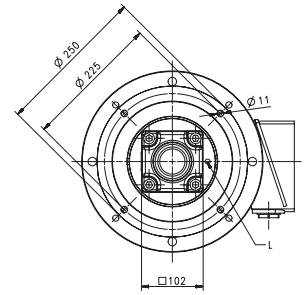
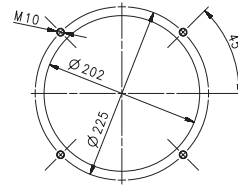

功率 50 Hz 2 极 kW	TFS3-H		
	A mm	B mm	C mm
2.2	647	178	126
3.0	699	198	166
4.0	682	222	177
5.5	726	262	202
7.5	776	262	202
11.0 / 15.0	895	314	237
18.5	955	314	237
22.0	955	356	286
30.0	1012	396	315

功率 60 Hz 2 极 kW	TFS3-H		
	A mm	B mm	C mm
2.54	647	178	126
3.0	699	198	166
3.7 / 4.55	682	222	177
5.5 / 6.3	726	262	202
7.5 / 8.6	776	262	202
11.0 / 12.6 / 15.0 / 17.3	895	314	237
18.5 / 21.3	955	314	237
22.0 / 25.3	955	356	286
30.0 / 33.5	1012	396	315
37.0 / 41.5	1037	396	315

询问表

传真	+86 21 59883979	日期	
邮箱	sales@zhishuntrade.com		

联系方式	
公司	
地址	
联系人	
电话	
邮箱	

泵	
年需求量 (每批)	

应用场合		
类型	材质	具体磨耗
<input type="checkbox"/> 研磨 铝 氧化物	<input type="checkbox"/> 铸铁	<input type="checkbox"/> 易燃物
<input type="checkbox"/> 研磨 CBN	<input type="checkbox"/> 黄铜	<input type="checkbox"/> 金刚石
<input type="checkbox"/> 钻孔	<input type="checkbox"/> 铝	<input type="checkbox"/> 碳化硅
<input type="checkbox"/> 车	<input type="checkbox"/> 钢	
<input type="checkbox"/> 磨		
<input type="checkbox"/> 其他 :	<input type="checkbox"/> 其他 :	<input type="checkbox"/> 其他 :

应用参数	
流量 (l/min.)	
压力 (bar)	

尺寸	
沉水深度	

介质	
冷却液	<input type="checkbox"/>
油	<input type="checkbox"/>
温度 (°C)	
黏度 (mm ² /s, cSt)	
密度 (kg/l)	
pH 值	
介质中是否含空气	<input type="checkbox"/> 是 <input type="checkbox"/> 否
介质中是否含润滑剂	<input type="checkbox"/> 是 <input type="checkbox"/> 否

过滤	
过滤等级 (μm)	
过滤类型	
ppm 等级符合 ISO 4406	
颗粒比重 (mg/l)	

驱动			
供电	<input type="checkbox"/> 3 x 400 V, 50 Hz	<input type="checkbox"/> 3 x 440 V, 60 Hz	<input type="checkbox"/> 3 x 208-230 V, 60 Hz
	<input type="checkbox"/> 3 x 415 V, 50 Hz	<input type="checkbox"/> 3 x 460 V, 60 Hz	<input type="checkbox"/> 3 x 200-220 V, 60 Hz
	<input type="checkbox"/> 3 x 380 V, 50 Hz	<input type="checkbox"/> 3 x 480 V, 60 Hz	<input type="checkbox"/> 其他 :
	<input type="checkbox"/> 3 x 200 V, 50 Hz	<input type="checkbox"/> 3 x 380 V, 60 Hz	
		<input type="checkbox"/> 3 x 400 V, 60 Hz	

电机	
防护等级 IP55	
绝缘等级 (F)	
环境温度 (°C)	
频率控制 (Hz)	从 到
开关次数 (每分钟)	
电机插头连接 HAN	<input type="checkbox"/> 是

其他	

advance

 expert

 smart

 express

 connect

BRINKMANN PUMPS技术服务

客户满意度是我们作为一个公司所能拥有的最大财富。这也是我们开发了“高阶”服务的原因-为满足客户特殊需求提供定制化的解决方案。例如，我们与客户探讨，积极支持客户确认新规格的实际需求，在现场确认应用及安装选项。然后开发适合客户的泵并提供试机支持服务。但是，我们的服务不止于此。您将从我们反映迅速的客户服务团队得益，使泵在寿命期内持续运转。而且还可以从Brinkmann Pumps高阶服务中的一系列额外的优势中获益。



EXPERT

专业技术支持的优势

凭借BRINKMANN PUMPS 专业技术移机多年的经验，我们将竭尽所能协助您在生产中达到更高的品质。



SMART

智能化解决方案的优势

BRINKMANN PUMPS为您提供智能化解决方案以及一系列利益使采购一台高品质水泵更为简便。



EXPRESS

快速服务的优势

在BRINKMANN PUMPS，我们特别聚焦在快速处理客户需求 and 订单上。



CONNECT

最大限度的可用性的优势

如果您期待卓越的可用性，BRINKMANN PUMPS则是您正确的选择。



 位置

● 代理



BRINKMANN PUMPS

K.H. Brinkmann GmbH & Co. KG

Friedrichstraße 2
58791 Werdohl
Germany

Brinkmann Pumps Inc.

47060 Cartier Drive
Wixom, MI 48393
United States

Brinkmann Pumps Japan Co. Ltd.

2-19-12, Engyo Fujisawa
Kanagawa, 252-0805
Japan

Phone +49 2392 5006-0
Fax +49 2392 5006-180
sales@brinkmannpumps.de
www.brinkmannpumps.de

Phone +1 248 926 9400
Fax +1 248 926 9405
sales@brinkmannpumps.com
www.brinkmannpumps.com

Phone +81 466 778320
Fax +81 466 778321
sales@brinkmannpumps.jp
www.brinkmannpumps.jp

Shanghai ZhiShun Trading Co., Ltd
Floor 2 Block 3, No.398 Songying Road,
Zhaoxiang Town
Qingpu District
Shanghai, 201703
China

上海挚舜贸易有限公司
上海市青浦区赵巷镇崧盈路398
号3幢2楼
上海, 201703
中国

Phone / 电话 +86 21 59883978
Fax / 传真 +86 21 59883979
sales@zhishuntrade.com
www.gtadtc.com