

Operating manual

Drive controller

Type: FKO

Status: 2023-04-24

Original operating manual

V2.60-a EN

Document-number: DOC0621_476xyz-12346-a

Legal notice

BRINKMANN PUMPEN
K. H. Brinkmann GmbH & Co. KG
Friedrichstraße 2
58791 Werdohl
Germany
Tel. +49 (0)2392 5006-0
Fax +49 (0)2392 5006-180
sales@brinkmannpumps.de

Exclusion of liability

All names, trademarks, product names or other designations used in this manual may be legally protected even if not indicated as such (e.g. as a trademark). BRINKMANN assumes no liability for their free usage.

The illustrations and texts have been compiled with great care.

However, the possibility of errors cannot be ruled out. The compilation is made without any guarantee.

General note on gender equality

BRINKMANN is aware of how language impacts on gender equality and always make an effort to reflect this in documentation. Nevertheless, for the sake of readability we are unable to use non-gender-specific terms throughout and use the masculine form instead.

© 2023 K.H. BRINKMANN GmbH & Co. KG

All rights reserved by BRINKMANN, including those of reproduction by photocopy and storage in electronic media. Commercial use or distribution of the texts, displayed models, diagrams and photographs appearing in this product is not permitted. This manual may not be reproduced, stored, transmitted or translated in any form or by means of any medium - in whole or in part - without prior written permission.

Contents

- 1. General information.....6**
 - 1.1 Information about documentation6
 - 1.1.1 Other applicable documents6
 - 1.1.2 Storing the documentation7
 - 1.2 Notes in this manual7
 - 1.2.1 Warnings7
 - 1.2.2 Warning symbols used7
 - 1.2.3 Signal words8
 - 1.2.4 Information notes8
 - 1.3 Symbols used in this manual9
 - 1.4 Labels on the drive controller9
 - 1.5 Qualified staff10
 - 1.6 Proper use10
 - 1.7 Responsibility10
 - 1.8 CE marking11
 - 1.9 Safety instructions11
 - 1.9.1 General information11
 - 1.9.2 Transport & storage13
 - 1.9.3 Information about commissioning13
 - 1.9.4 Instructions concerning operation14
 - 1.9.5 Maintenance and inspection15
 - 1.9.6 Repairs16
- 2. Overview of the drive controller17**
 - 2.1 PIN assignment MMI*/connecting cable17
 - 2.2 Description of the FKO drive controller17
- 3. Installation18**
 - 3.1 Safety instructions for installation18
 - 3.2 Recommended preliminary fuses / line protection18
 - 3.3 Installation requirements19
 - 3.3.1 Suitable ambient conditions19
 - 3.3.2 Suitable installation location for the motor-integrated drive controller20
 - 3.3.3 Basic connection versions20
 - 3.3.4 Short circuit and ground protection23
 - 3.3.5 Wiring instructions23
 - 3.3.5.1 Option using device plug connectors on the housing26
 - 3.3.6 Preventing electromagnetic interferences28
 - 3.4 Installing the drive controller integrated in the motor29
 - 3.4.1 Power connection29
 - 3.4.2 Connections for brake resistor33
 - 3.4.3 Control connections X5, X6, X733
 - 3.4.4 Connection diagram38
 - 3.5 Installing the wall-mounted drive controller39
 - 3.5.1 Suitable installation location for wall mounting39
 - 3.5.2 Mechanical installation sizes A - C40
 - 3.5.3 Mechanical installation of size D45
 - 3.5.4 Power connection52
 - 3.5.5 Brake chopper52
 - 3.5.6 Control connections52
 - 3.6 Disassembly and assembly of the FKO fan, size "D"53

3.6.1	Fan disassembly	53
3.6.2	Fan assembly	55
4.	Commissioning	56
4.1	Safety instructions for commissioning	56
4.2	Communication	57
4.3	Block diagram	58
4.4	Commissioning steps	59
4.4.1	Commissioning using the PC:	59
4.4.2	Commissioning using PC, combined with MMI option	60
5.	Parameter	61
5.1	Safety instructions for working with parameters	61
5.2	General information on parameters	62
5.2.1	Explanation of operating modes	62
5.2.2	Structure of the parameter tables	65
5.3	Application parameters	66
5.3.1	Basic parameter	66
5.3.2	Fixed frequency	71
5.3.3	Motor potentiometer	71
5.3.4	PID process controller	72
5.3.5	Analogue inputs	75
5.3.6	Digital inputs	78
5.3.7	Analogue output	78
5.3.8	Digital outputs	79
5.3.9	Relay	80
5.3.10	Virtual output	82
5.3.11	External fault	83
5.3.12	Motor current limit	84
5.3.13	Stall detection	84
5.3.14	Additional function	85
5.3.15	HMI Parameters	86
5.3.16	Fieldbus	87
5.4	Performance parameters	90
5.4.1	Motor data	90
5.4.2	I^2t 93	
5.4.3	Switching frequency	93
5.4.4	Controller data	93
5.4.5	Quadratic characteristic curve	95
5.4.6	Synchronous motor controller data	96
6.	Error detection and troubleshooting	97
6.1	List of the LED flash codes for error recognition	97
6.2	List of errors and system errors	98
7.	Disassembly and disposal	101
7.1	Drive controller disassembly	101
7.2	Information on correct disposal	101
8.	Technical data	102
8.1	General data	102
8.1.1	General technical data for 400V devices	102
8.1.2	General technical data for 230 V devices	103
8.1.3	Specification of interfaces	104
8.1.4	Power loss table	105
8.2	Derating of output power	106
8.2.1	Derating due to increased ambient temperature	106
8.2.2	Derating due to installation altitude	107
8.2.3	Derating due to switching frequency	108

9.	<i>Optional accessories</i>	110
9.1	Adapter plates	110
9.1.1	Wall adapter plates (standard)	110
9.2	MMI handheld controller including a 3 m RJ9 connection cable with M12 plug.....	112
9.3	PC communication cable USB on M12/RS485 plug (converter integrated).....	112
10.	<i>Approvals, standards and guidelines</i>	113
10.1	EMC limit classes	113
10.2	Classification acc. to IEC/EN 61800-3	114
10.3	Harmonics currents and grid impedance for devices > 16 A and ≤ 75 A.....	114
10.4	Standards and guidelines	114
10.5	UL approval.....	115
10.5.1	UL Specification (English version)	115
10.5.2	Homologation CL (Version en française)	117
11.	<i>Quickstart guide</i>	119
11.1	Quickstart guide	119
11.2	Quickstart guide for synchronous motors	120
12.	<i>Index</i>	121
13.	<i>EC declaration of conformity</i>	125

1. General information

Thank you for choosing an FKO drive controller from BRINKMANN!
Our FKO drive controller platform is designed to be universally usable with all common motor types.

If you have any technical questions, please call our central service hotline:

Tel. +49 (0)2392 5006-0

Fax +49 (0)2392 5006-180

sales@brinkmannpumps.de

1.1 Information about documentation

The following information explains how to navigate through the documentation.

Read this manual carefully in its entirety. It contains important information for operating the FKO.

We assume no liability for any damage resulting from non-observance of this manual.

This manual is an integral part of the product and applies exclusively to the FKO from K.H. Brinkmann GmbH & Co. KG.

Provide the operator of the system with this manual so it is available when needed.

1.1.1 Other applicable documents

This refers to all manuals that describe how to operate the drive controller system and any other manuals for the equipment used.

1	2	3	4	5	6	7	8	9	10	11	12
---	---	---	---	---	---	---	---	---	----	----	----

1.1.2 Storing the documentation

Store this operating manual and all other applicable documents carefully so they are available when needed.

1.2 Notes in this manual

1.2.1 Warnings

The warnings refer to life-threatening dangers. Serious injuries possibly resulting in death may occur.

Each warning consists of the following elements:

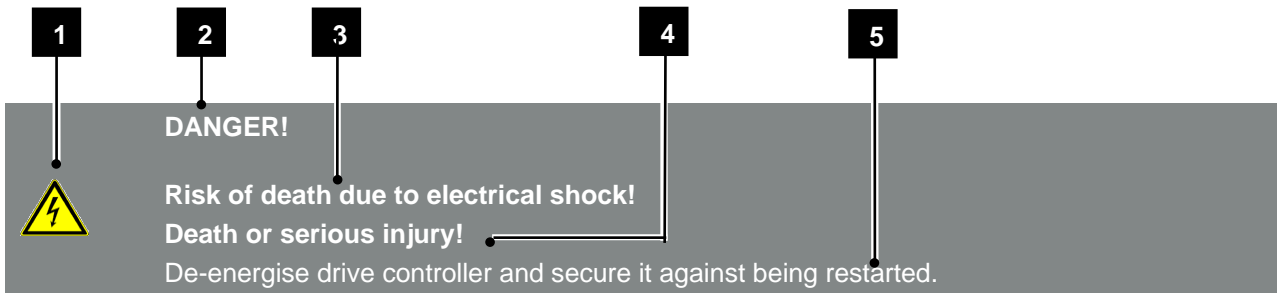

Fig. 1: Structure of the warnings

- 1** Warning symbol
- 2** Signal word
- 3** Type of danger and its source
- 4** Possible consequence(s) of failure to comply
- 5** Corrective actions

1.2.2 Warning symbols used

Symbol	Meaning
	Danger
	Danger due to electrical shock and discharge
	Danger due to electromagnetic fields

1	2	3	4	5	6	7	8	9	10	11	12
---	---	---	---	---	---	---	---	---	----	----	----

1.2.3 Signal words

Signal words are used to identify the severity of the danger.

DANGER

Indicates a direct hazard with a high level of risk, which, if not avoided, will result in death or serious injury.

WARNING

Indicates a hazard with a moderate level of risk, which, if not avoided, will result in death or serious injury.

CAUTION

Indicates a hazard with a low level of risk, which, if not avoided, may result in minor or slight injury or property damage.

1.2.4 Information notes

Information notes contain important instructions for the installation and problem-free operation of the drive controller. These must be followed at all times.

The information notes also point out that failure to observe can result in damage to property or financial damages.

	IMPORTANT INFORMATION
The drive controller may only be assembled, operated, maintained and installed by trained and qualified staff.	

Fig. 2: Example of an information note

Symbols within the information notes

Symbol	Meaning
	Important information
	Damage to property possible

Other notes

Symbol	Meaning
	INFORMATION
	Enlarged view

1	2	3	4	5	6	7	8	9	10	11	12
---	---	---	---	---	---	---	---	---	----	----	----

1.3 Symbols used in this manual

Symbol	Meaning
1., 1., 3. ...	Consecutive steps in a handling instruction
→	Effect of a handling instruction
✓	Final result of a handling instruction
■	List

Fig. 3: Symbols and icons used

Abbreviations used

Abbreviation	Explanation
Tab.	Table
Fig.	Figure
It.	Item
Ch.	Chapter

1.4 Labels on the drive controller

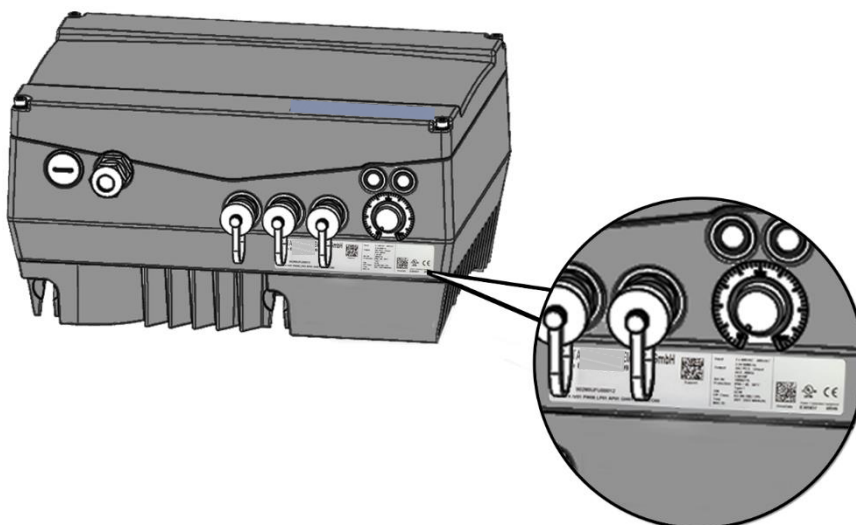

Fig. 4: Labels on the drive controller

Signs and labels are affixed to the drive controller. These may not be altered or removed.

Symbol	Meaning
	Danger due to electrical shock and discharge
	Danger due to electrical shock and discharge. Wait two minutes (discharge time of the capacitors) after shut-down
	Additional earth connection
	Observe and read operating manual

1

2

3

4

5

6

7

8

9

10

11

12

1.5 Qualified staff

In the context of this operating manual, qualified staff refers to electronics specialists who are familiar with the installation, assembly, commissioning and operation of the drive controller and the dangers involved, and whose specialist training and knowledge of relevant standards and regulations provide them with the necessary abilities.

1.6 Proper use

If the device is installed in a machine, drive controllers may not be commissioned (i.e. intended operation may not begin) until it has been determined that the machine complies with the regulations of EC Directive 2006/42/EC (Machinery Directive); DIN EN 60204-1; VDE 0113-1 must be observed.

Commissioning (i.e. beginning intended operation) is only permitted if the EMC Directive (2014/30/EU) is complied with.

The harmonised standards of DIN EN 50178; VDE 0160 must be applied for this drive controller along with DIN EN 61439-1/DIN EN 61439-2; VDE 0660-600.

This drive controller may not be operated in areas where there is a danger of explosion!

Repairs may only be performed by authorised repair bodies.

Independent and unauthorised intervention may result in death, injury or property damage.

The warranty provided by BRINKMANN will be invalidated in such cases.



IMPORTANT INFORMATION

External mechanical loads on the housing are not permitted!



IMPORTANT INFORMATION

Using drive controllers in equipment that is not fixed is considered as an exceptional environmental condition and is only permitted if allowed by the standards and guidelines applicable on site.

1.7 Responsibility

As a basic principle, electronic devices are not fail-safe. The operator and/or the contractor setting up the machine or system is responsible for ensuring that the drive switches to a safe state if the device fails.

The “Electrical equipment of machines” section in DIN EN 60204-1; VDE 0113-1, “Safety of machinery” describes the safety requirements for electrical control units. These are provided for the safety of people and machines and must be observed in order to retain the functional capability of the machine or system.

An emergency stop feature does not have to result in the voltage supply to the drive being switched off. To avoid dangerous situations, it may be useful for individual drives to remain operational or for specific safety procedures to be initiated.

The effectiveness of emergency stop measures is evaluated by means of a risk assessment for the machine or system and its electrical equipment, and is determined by selecting a circuit category according to DIN EN 13849 “Safety of machinery – Safety-related parts of control systems”.

1.8 CE marking

BRINKMANN hereby declares that the drive controller described in this document complies with the basic requirements and other relevant conditions of the directives listed below.

- Directive 2014/30/EU
(on the approximation of the laws of the Member States relating to electromagnetic compatibility (EMC)).
- Directive 2014/35/EU
(on the harmonisation of the laws of the Member States relating to the making available on the market of electrical equipment designed for use within certain voltage limits – in short: Low Voltage Directive).
- Directive 2011/65/EU
(Restriction of the use of certain hazardous substances in electrical and electronic equipment, in short: RoHS Directive)
- Directive 2014/53/EU
(relating to the making available on the market of radio equipment and repealing Directive 1999/5/EC)

See page 125 EC declaration of conformity

1.9 Safety instructions

The following warnings, precautionary measures and information are provided for your safety and serve to prevent damage to the drive controller and the components connected to it.

This chapter contains warnings and information that are generally applicable when handling drive controllers. They are split into general information, transport & storage and dismantling & disposal.

Specific warnings and comments that apply to specific activities can be found at the start of the appropriate chapters and are repeated or added to at various critical points in these chapters.

Please read this information carefully as it is provided for your personal safety and will also prolong the life of the drive controller and connected devices.

1.9.1 General information



IMPORTANT INFORMATION

Carefully read this operating manual and the warning signs affixed to the drive controller before installation and commissioning. Make sure that all warning signs on the drive controller are legible; replace any missing or damaged signs.

They contain important information on the installation and operation of the drive controller. In particular, note the information in the "Important information" chapter.

BRINKMANN assumes no liability for damages arising from the non-observance of this operating manual.

This operating manual is an integral part of the product. It applies exclusively to the drive controller from BRINKMANN.

Keep the operating manual close to the drive controller so it is easily accessible to all users.

1

2

3

4

5

6

7

8

9

10

11

12



IMPORTANT INFORMATION

The drive controller can only be operated safely if the required environmental conditions listed in the “Suitable environmental conditions” chapter are met.



DANGER!

**Risk of death due to electrical shock!
Death or serious injury!**

De-energise drive controller and secure it against being restarted.



DANGER!

**Risk of death due to electrical shock!
Death or serious injury!**

Always ground the device in accordance with DIN EN 61140; VDE 0140, NEC and other relevant standards.

The drive controller must be grounded with the motor according to relevant regulations. Non-compliance may result in death or serious injury.

If spring elements are not used when assembling the adapter plate, there must be an extra connection between the motor and drive controller to produce a correct protective conductor connection.



DANGER!

**Risk of death due to revolving mechanical parts!
Death or serious injury!**

De-energise drive controller and secure it against being restarted.



DANGER!

**Risk of death due to fire or electrical shock!
Death or serious injury!**

Always use the drive controller as intended.

Do not modify the drive controller.

Only use spare parts and accessories sold or recommended by the manufacturer.

During assembly, ensure a sufficient distance from neighbouring parts.



CAUTION!

**Risk of burns from hot surfaces!
Serious burns to the skin from hot surfaces!**

Allow the drive controller's cooling elements to cool sufficiently.

1

2

3

4

5

6

7

8

9

10

11

12

1.9.2 Transport & storage



DAMAGE TO PROPERTY POSSIBLE

Risk of damage to drive controller!

Risk of damage to drive controller from improper transport, storage, installation and assembly!

In general, transport the drive controller correctly in its original packaging on a pallet.

Always store the drive controller properly.

Only allow qualified staff to undertake installation and assembly.

1.9.3 Information about commissioning



DANGER!

Risk of death due to electrical shock!

Death or serious injury!

De-energise drive controller and secure it against being restarted.

The following terminals may lead to dangerous currents even when the motor is not running:

- Supply terminals X1: L1, L2, L3
- Motor connection terminals X2: U, V, W
- Connecting terminals X6, X7: Relay contacts for relays 1 and 2
- PTC terminals T1/ T2

1

2

3

4

5

6

7

8

9

10

11

12



IMPORTANT INFORMATION

- Only use mains connections with hardwiring.
- Ground the drive controller in accordance with DIN EN 61140; VDE 0140-1.
- The FKO may have touch currents of > 3.5 mA.
In accordance with DIN EN 61800-5-1, an extra protective grounding conductor of the same cross-section as the original protective grounding conductor should therefore be fitted. A second protective grounding conductor can be connected under the mains supply (position marked with a ground symbol) on the outside of the device. A M6 x 12 screw (4.0 Nm torque) suitable for this connection is provided with the adapter plate.
- If three-phase frequency inverters are used, the use of conventional type A FI protection switches RCDs (residual current-operated protective devices) are not permissible as protection against direct or indirect contact.
According to DIN VDE 0160 and EN 50178, the FI protection switch must be universal current sensitive (RCD type B).



IMPORTANT INFORMATION

- If different voltages are used (e.g. +24 V/230 V), crossing cable runs are not permitted under any circumstances. The operator must also ensure compliance with the applicable regulations (e.g. double or reinforced insulation acc. to DIN EN 61800-5-1).
- The drive controller contains components susceptible to electrical discharge. These may be destroyed through improper handling. Therefore, precautionary measures against electrostatic charges must be taken when work is performed on these components.

1.9.4 Instructions concerning operation

DANGER!



Risk of death due to electrical shock!

Death or serious injury!

De-energise drive controller and secure it against being restarted.

DANGER!



Risk of death due to revolving mechanical parts!

Death or serious injury!

De-energise drive controller and secure it against being restarted.

1

2

3

4

5

6

7

8

9

10

11

12



IMPORTANT INFORMATION

Observe the following instructions during operation:

- The drive controller runs at high voltages.
- When electrical devices are operated, some of their parts are always subject to dangerous voltage.
- Emergency stop equipment according to DIN EN 60204-1; VDE 0113-1:2007-06 must function in all the control device's operating modes.
Resetting the emergency stop equipment may not result in uncontrolled or undefined restarting.
- In order to ensure safe disconnection from the mains, the mains cable has to be fully disconnected from the drive controller in a synchronous manner.
- A pause of at least 1 to 2 mins must be observed between consecutive mains activations for devices with a single-phase feed and for size D (11 to 22 kW).
- A pause of at least 3 sec. must be observed between consecutive grid connections for devices with three-phase feed-in in sizes A - C (0.55 to 7.5 kW).
- Certain parameter settings may result in the drive controller restarting automatically after the supply voltage has failed.



DAMAGE TO PROPERTY POSSIBLE

If the information is not observed, the drive controller could be damaged and destroyed during subsequent commissioning.

Observe the following instructions during operation:

- The motor parameters, especially the I^2t settings, have to be configured properly to provide proper motor overload protection.
- The drive controller has internal motor overload protection. See parameters 33.010 and 33.011. I^2t is ON by default. Motor overload protection can also be ensured via an external PTC.
- The drive controller must not be used as "Emergency stop equipment" (see DIN EN 60204-1; VDE 0113-1:2007-06).

1.9.5 Maintenance and inspection

The drive controllers may only be maintained and inspected by electricians with recognised training. Unless explicitly described in this operating manual, changes to hardware and software may only be undertaken by BRINKMANN experts or persons authorised by BRINKMANN.

Cleaning the drive controllers

Drive controllers are maintenance-free if operated as intended. If the air contains dust, the cooling fins of the motor and drive controller have to be cleaned regularly.

If devices are fitted with integrated fans (optional for size C, standard for size D), we would recommend cleaning with compressed air.

1	2	3	4	5	6	7	8	9	10	11	12
---	---	---	---	---	---	---	---	---	----	----	----

Measurement of insulation resistance on control part

An insulation test on the control card's input terminals is not permitted.

Measurement of insulation resistance on power part

The power part of an FKO is tested with 2.02 kV in the course of series testing.

Should the insulation resistance have to be measured during a system test, this can be done under the following conditions:

- an insulation test can be undertaken for the power part alone,
- to avoid excessively high voltages, all the FKO's connection cables must be disconnected before testing,
- a 500 V DC insulation tester should be used.

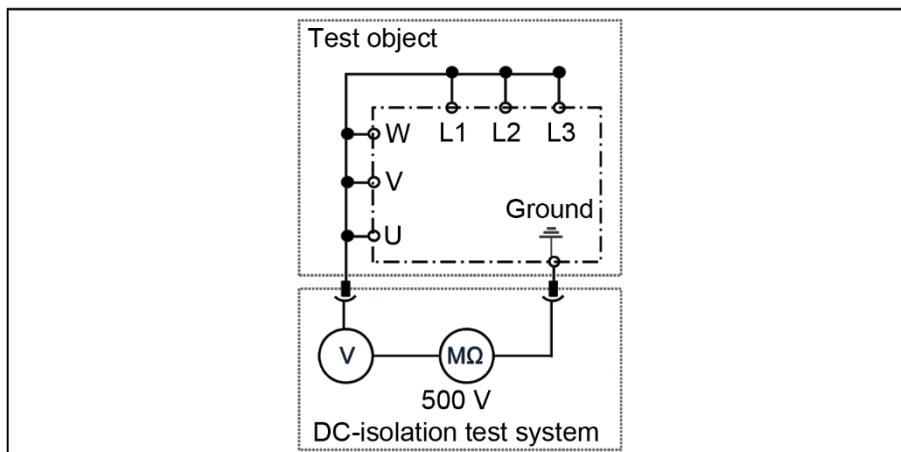

Fig. 5: Insulation test on the power board

Pressure test on an FKO



IMPORTANT INFORMATION

A pressure test is not permitted on a standard FKO.

1.9.6 Repairs



DAMAGE TO PROPERTY POSSIBLE

If the information is not observed, the drive controller could be damaged and destroyed during subsequent commissioning.

- Repairs to the drive controller may only be performed by the BRINKMANN Service department.

DANGER!



Risk of death due to electrical shock!

Death or serious injury!

De-energise drive controller and secure it against being restarted.



Danger due to electrical shock and discharge. Wait two minutes (discharge time of the capacitors) after shut-down.

1	2	3	4	5	6	7	8	9	10	11	12
---	---	---	---	---	---	---	---	---	----	----	----

2. Overview of the drive controller

This chapter contains information on the scope of delivery for the drive controller and the function description.

2.1 PIN assignment MMI*/connecting cable

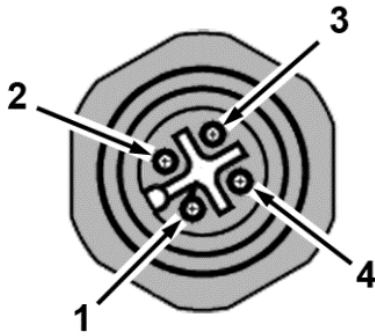

Fig. 6: M12 plug PIN assignment

Description: Round plug (plug)
4-pin M12 A-coded

M12 plug assignment	Signal
1	24 V
2	RS485 - A
3	GND
4	RS485 - B

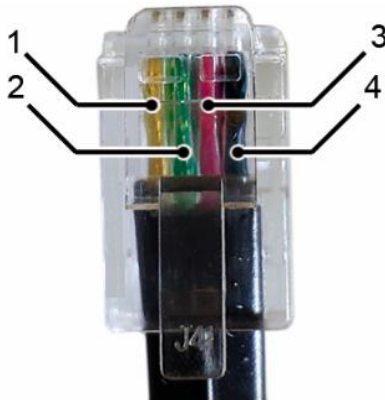

Fig. 7: RJ9 plug connector

Description: RJ9 plug connector

Pin	Signal
1	yellow
2	green
3	Red
4	brown
Attention: The colours may vary!	

2.2 Description of the FKO drive controller

The FKO drive controller is a device for the speed control of three-phase AC motors.

The drive controller can be integrated in the motor (with the standard adapter plate) or fitted close to the motor (with the wall installation adapter plate).

The permitted ambient temperatures specified in the technical data refer to operation at nominal load. In many cases, higher temperatures may be permitted after a detailed technical analysis. These have to be approved by BRINKMANN on a case-by-case basis.

* Man-machine interface

3. Installation

3.1 Safety instructions for installation



DANGER!

Risk of death due to revolving mechanical parts!
Death or serious injury!

De-energise drive controller and secure it against being restarted.

Only allow appropriately qualified staff to install the drive controller.

Only use staff who are trained in mounting, installation, commissioning and handling.

Always ground the device in accordance with DIN EN 61140; VDE 0140, NEC and other relevant standards.

The drive controller must be grounded with the motor according to relevant regulations. Non-compliance may result in death or serious injury.

If spring elements are not used when assembling the adapter plate, there must be an extra connection between the motor and drive controller to produce a correct protective conductor connection

Unused open cable ends in the motor terminal box must be insulated.

Use suitable line circuit breakers with the prescribed nominal current between the mains and drive controller.

Mains connections must be hardwired.

3.2 Recommended preliminary fuses / line protection

FKO M	Size A 1 x 230 V AC	Size A 3 x 400 V AC	Size B 3 x 400 V AC	Size C 3 x 400 V AC	Size D 3 x 400 V AC	Size D 3 x 400 V AC
Rated motor speed	up to 1.1 kW	up to 1.5 kW	up to 4.0 kW	up to 7.5 kW	up to 15 kW	up to 22 kW
Mains current	9.2 A	3.3 A	7.9 A	14.8 A	28.2 A	39.9 A
Mains current 150% (overload 60 s)	13.8 A	4.95 A	11.85 A	22.2 A	42.3 A	51.87 A
Line circuit breaker - recommendation	C 16	C 10	C 16	C 25	C 50	C 63
Characteristics C = line circuit breaker tripping between 6 – 10 times I _n						
	The cross-section of the supply line must be designed according to the transfer category and maximum permitted current. The contractor commissioning the device must ensure protection for the power line.					

3.3 Installation requirements

3.3.1 Suitable ambient conditions

Conditions	Values
Altitude of the installation location:	up to 1000 m above sea level / over 1000 m with reduced performance (1% per 100 m) (max. 2000 m), see chapter 8.2
Ambient temperature:	-25 °C to +50 °C (different ambient temperatures may be possible in individual cases), see chapter 8.2
Relative air humidity	≤ 96 %, condensation not permitted.
Resistance to vibration and shock:	DIN EN 60068-2-6 severity 2 (vibration from transport) DIN EN 60068-2-27 (vertical impact test) 2...200 Hz for sinusoidal vibrations.
Electromagnetic compatibility:	Immune to interference acc. to DIN EN 61800-3
Cooling:	Surface cooling: sizes A to C: free convection; size C: optionally with integrated fan; size D: with integrated fans.

Tab. 1: Ambient conditions

- Ensure that the housing type (protection class) is suitable for the operating environment:
 - Ensure that the seal between the motor and the adapter plate is inserted correctly.
 - All unused cable screw connections must be sealed.
 - Check that the cover of the drive controller is closed and bolted down tightly.
 - Size A – C (4 x M4 x 28) 2 Nm,
 - Size D (4 x M6 x 28) 4 Nm.



DAMAGE TO PROPERTY POSSIBLE

Failure to comply with the information may result in damage to the drive controller!
When attaching a cover with integrated foil keypad, be absolutely sure that the flat ribbon cable is not pinched.

Although the drive controller can, in principle, be painted later on, the user must nevertheless check the material compatibility of the intended paint.



DAMAGE TO PROPERTY POSSIBLE

Failure to comply with this requirement may eventually result in the loss of the protection class (particularly in respect to seals and fibre-optic elements).

The FKO is supplied in black RAL 9005 (black) as standard.

Disassembling the circuit boards (even for the purpose of painting the housing sections) renders the warranty void!

Mounting points and sealing surfaces must be kept free of paint for purposes of EMC and grounding!

1	2	3	4	5	6	7	8	9	10	11	12
---	---	---	---	---	---	---	---	---	----	----	----

3.3.2 Suitable installation location for the motor-integrated drive controller

Ensure that the motor with a motor-integrated drive controller is only installed and operated if aligned as shown in the following diagram.

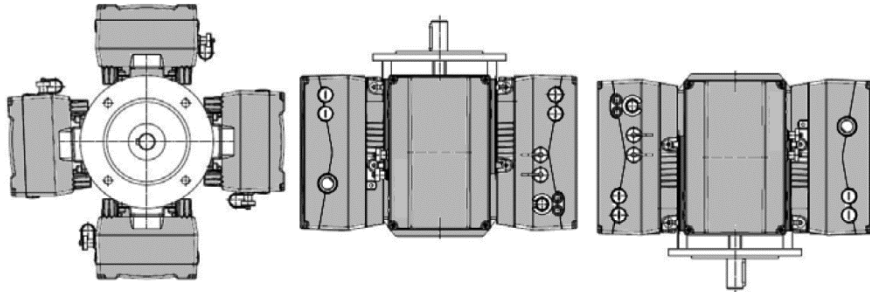

Fig. 8: Motor installation location/permitted alignments



IMPORTANT INFORMATION

Ensure that no condensate from the motor can enter the drive controller during and after installation.

3.3.3 Basic connection versions

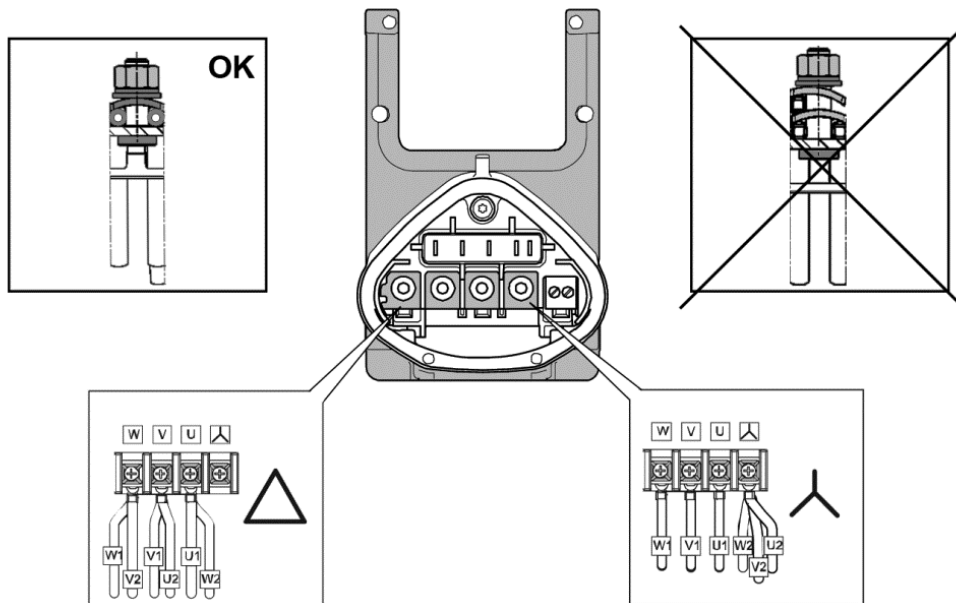
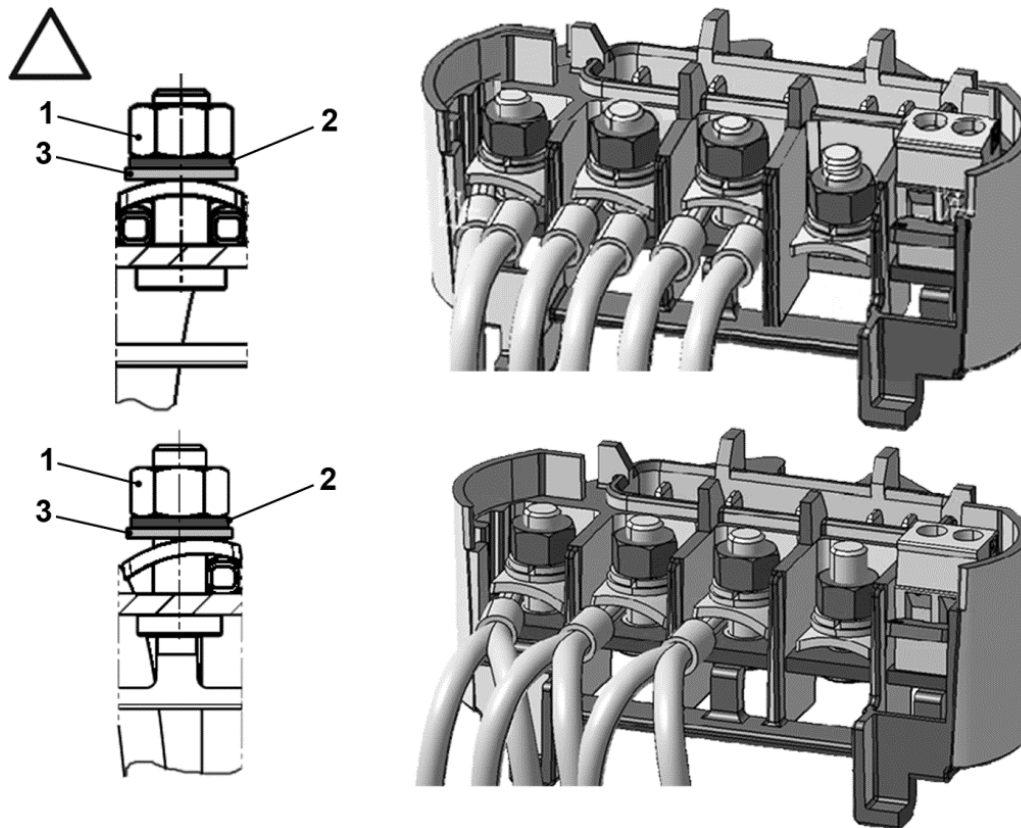



Fig. 9: Star or triangle connection for drive controllers integrated in the motor

1	2	3	4	5	6	7	8	9	10	11	12
---	---	---	---	---	---	---	---	---	----	----	----

Triangle connection variant



- 1. Nut $M_A = 5 \text{ Nm}$
- 2. Circlip
- 3. Plain washer

DANGER!

Risk of death due to electrical shock!
Death or serious injury!
 De-energise drive controller and secure it against being restarted.

! **IMPORTANT INFORMATION**
 Regularly check that the nuts (1) are secure!

1	2	3	4	5	6	7	8	9	10	11	12
---	---	---	---	---	---	---	---	---	----	----	----

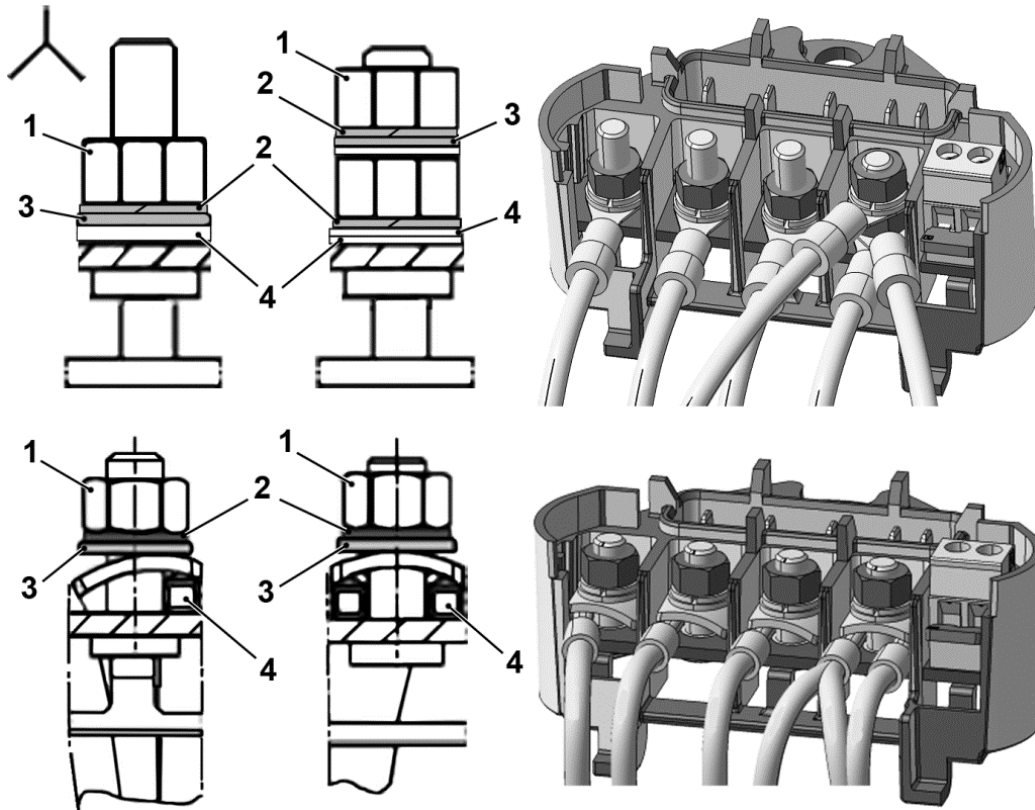
Star connection variant



- | | |
|-----------------------------|-----------------|
| 1. Nut $M_A = 5 \text{ Nm}$ | 3. Plain washer |
| 2. Circlip | 4. Cable shoe |

DANGER!



Risk of death due to electrical shock!

Death or serious injury!

De-energise drive controller and secure it against being restarted.



IMPORTANT INFORMATION

Regularly check that the nuts (1) are secure!



DAMAGE TO PROPERTY POSSIBLE

Risk of damage to the drive controller.

Correct phase assignment must be observed when connecting the drive controller, otherwise the motor may be overloaded.

1	2	3	4	5	6	7	8	9	10	11	12
---	---	---	---	---	---	---	---	---	----	----	----

The supplied assembly material can be used to connect core end sleeves and cable shoes. Fig. 5 shows the different connection options.

DANGER!

 **Risk of death due to electrical shock!**
Death or serious injury!

De-energise drive controller and secure it against being restarted.
 Unused open cable ends in the motor terminal box must be insulated.

 **IMPORTANT INFORMATION**

If a thermal resistor (PTC or Klixon) is used, the bridging contact fitted on the connection terminal for the PTC in the delivery state has to be removed.

The cross-section of the supply line must be designed according to the transfer category and maximum permitted current. The contractor commissioning the device must ensure protection for the power line.

3.3.4 Short circuit and ground protection

The drive controller contains an internal short circuit and ground protection.

3.3.5 Wiring instructions

The control connections of the application card are located inside the drive controller. The configuration may vary depending on the version.

Control terminals (sizes A – D)

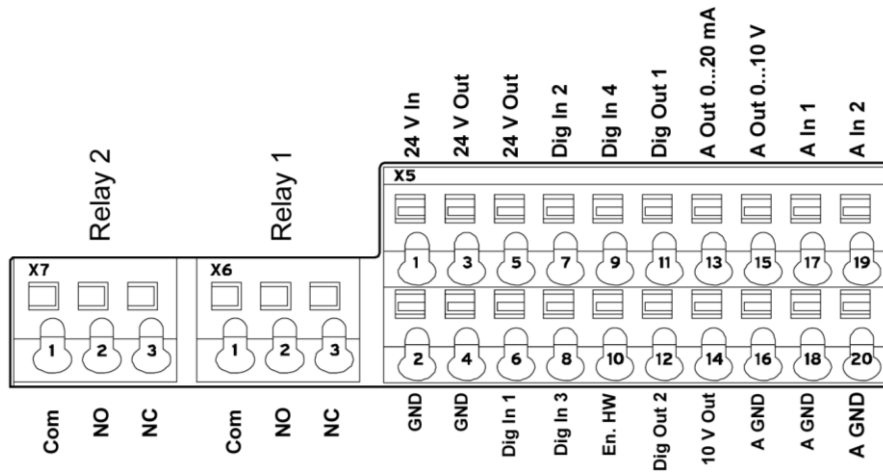

Sizes A - D		
X5 - X7	Terminals:	Plug terminal clamp with activation button (slot screwdriver, max. width 2.5 mm)
	Connection cross-section:	0.5 to 1.5 mm ² , single-wire, AWG 20 to AWG 14
	Connection cross-section:	0.75 to 1.5 mm ² , fine-wired, AWG 18 to AWG 14
	Connection cross-section:	0.5 to 1.0 mm ² , fine-wired, (core end sleeves with and without plastic collar)
	Length of stripped insulation:	9 to 10 mm

1	2	3	4	5	6	7	8	9	10	11	12
---	---	---	---	---	---	---	---	---	----	----	----

Power connections (sizes A – C)

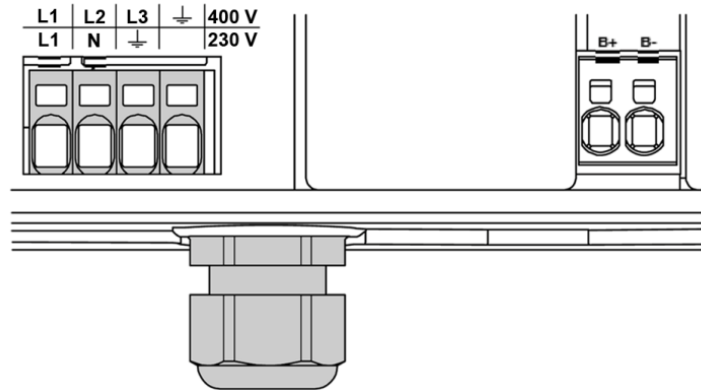

Sizes A - C		
X1 mains + B - brake resistor	The terminals for the mains cable are located inside the drive controller. The FKO also has the option of being equipped with terminals for connecting a brake resistor. The configuration may vary depending on the version.	
	Core end sleeves with plastic collars and lugs are recommended.	
	Terminals:	Spring force connection (slot screwdriver, max. width 2.5 mm)
	Conductor cross-section, rigid	min. 0.2 mm ² max. 10 mm ²
	Conductor cross-section, flexible	min. 0.2 mm ² max. 6 mm ²
	Conductor cross-section, flexible with core end sleeve without plastic sleeve	min. 0.25 mm ² max. 6 mm ²
	Conductor cross-section, flexible with core end sleeve with plastic sleeve	min. 0.25 mm ² max. 4 mm ²
	2 conductors of the same cross-section, flexible with TWIN-AEH with plastic sleeve	min. 0.25 mm ² max. 1.5 mm ²
	AWG/kcmil conductor cross-section according to UL/CUL	min. 24 max. 8
	Length of stripped insulation:	15 mm
Mounting temperature:	-5°C to +100°C	

1	2	3	4	5	6	7	8	9	10	11	12
---	---	---	---	---	---	---	---	---	----	----	----

Power connections (size D)

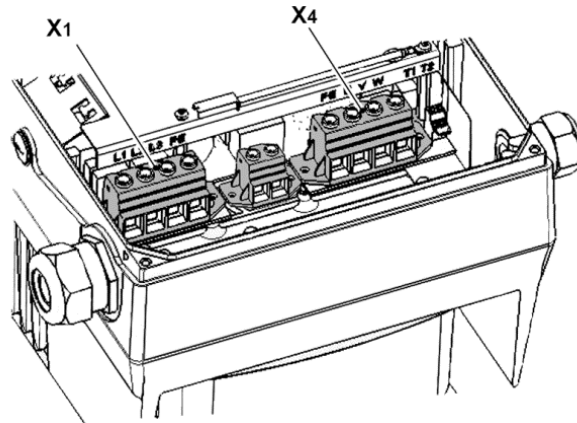

Size D		
X1 mains / X4 motor + B - brake resistor	The terminals for the mains cable are located inside the drive controller. The FKO also has the option of being equipped with terminals for connecting a brake resistor. The configuration may vary depending on the version.	
	Core end sleeves with plastic collars and lugs are recommended.	
	Torque min. 2.5 Nm / max. 4.5 Nm	
	Conductor cross-section:	rigid min. 0.5 mm ² / rigid max. 35 mm ²
	Conductor cross-section, flexible:	min. 0.5 mm ² / max. 25 mm ²
	Conductor cross-section, flexible with core end sleeve without plastic collar	min. 1 mm ² max. 25 mm ²
	Conductor cross-section, flexible with core end sleeves with plastic sleeve	min. 1.5 mm ² max. 25 mm ²
	AWG / kcmil conductor cross-section according to UL/CUL	min 20 max. 2
	2 conductors of the same cross-section, rigid	min. 0.5 mm ² max. 6 mm ²
	2 conductors of the same cross-section, flexible	min. 0.5 mm ² max. 6 mm ²
	2 conductors of the same cross-section, flexible with AEH without plastic sleeve	min. 0.5 mm ² max. 4 mm ²
	2 conductors of the same cross-section, flexible with TWIN-AEH with plastic sleeve	min. 0.5 mm ² max. 6 mm ²
	AWG according to UL/CUL	min. 20 max. 2

3.3.5.1 Option using device plug connectors on the housing

If standard cable/blanking connections on the housing of the FKO are replaced by device plug connectors, the following must be observed:

When using the frequency converter with device plug connectors, electrical data for the mains input voltage changes:

Electrical data – mains voltage: 280 VDC -10 %...630 VDC

DANGER!



Risk of death due to fire or electrical shock!

Death or serious injury!

De-energise drive controller and secure it against being restarted.

Only allow appropriately qualified staff to undertake disassembly and assembly.

Only use staff who are trained in mounting, installation, commissioning and handling.

Always ground the device in accordance with DIN EN 61140; VDE 0140, NEC and other relevant standards.

DANGER!



Risk of death due to fire or electrical shock!

Death or serious injury!

Frequency converters must be inspected for damage before installation. In case of damage before, during or after commissioning, the frequency converter must be shut down immediately.

The drive controller may only be maintained and installed by trained and qualified staff.

Only use staff who are trained in mounting, installation, commissioning and handling.

DANGER!



Risk of death due to fire or electrical shock!

Death or serious injury!

This drive controller may not be operated in areas where there is a danger of explosion!



IMPORTANT INFORMATION

Using the customer's device plug connectors on the drive controller housing automatically voids the devices' TÜV certification for functional safety.

This device is not allowed for functional safety (SIL) applications

To maintain the device-specific IP protective class, make sure that the plug connectors are firmly locked to the housing when mounting them.

The shock and vibration resistance of the device plug connector should at least correspond to the specifications given in the FKO data sheet.

The single wire cross-section must be compliant with the power requirements.

Make sure that the cables are connected properly!

The device plug connectors for the extra-low voltage signals must conform to extra-low voltage according to IEC 60449.

The device plug connectors for the mains supply must conform to low voltage according to IEC 60449.

Select the cross-section of the mains cable according to the type of installation and the maximum permissible current.

The contractor commissioning the device must ensure that the mains cable is protected!



IMPORTANT INFORMATION

- Brinkmann accepts no liability for the selection/dimensioning of the plugs or cables.
- Using the customer's device plug connectors on the drive controller housing automatically voids the cULus device approval.
- The customer is free to declare their own CE conformity or to have this confirmed by a third-party expert or external approval body.
- The device plug connectors for the mains supply must conform to low voltage according to IEC 60449.
- The EMC may be negatively affected by using device plug connectors.
We therefore recommend ensuring and documenting compliance with the EMC Directive by means of suitable EMC measurements.

1

2

3

4

5

6

7

8

9

10

11

12

3.3.6 Preventing electromagnetic interferences

To ensure immunity to interference, be sure that control lines run separately from grid and motor cables. Where possible use shielded lines for analogue control circuits.

At the line end, the shielding should be fitted with great care. The use of EMC cable screw connections is recommended for this purpose. These are not part of the scope of delivery.

Ensure that no parasitic currents (compensating currents etc.) can flow via an analogue control cable's shielding.

Route the control lines as far away as possible from the power lines. Under certain circumstances, separate power ducts should be used.

If lines do cross, an angle of 90° should be observed as far as possible.

Upstream switch elements, such as protector switches and brake coils or circuit elements that are operated via the outputs of the drive controller have to be interference-suppressed.

RC circuits are suitable as AC voltage protector switches, while free-wheeling diodes or varistors are usually used as DC voltage protector switches. These interference suppression devices are attached directly to the protector switch coils.



IMPORTANT INFORMATION

Where possible, the power for a mechanical brake should be supplied in a separate cable.

Power connections between the drive controller and motor should always be shielded or reinforced, and the shielding must have large-scale grounding at both ends! The use of EMC cable screw connections is recommended. These are not part of the scope of delivery.

Wiring suitable for EMC must be ensured.

1	2	3	4	5	6	7	8	9	10	11	12
---	---	---	---	---	---	---	---	---	----	----	----

3.4 Installing the drive controller integrated in the motor

3.4.1 Power connection

Power connection for sizes A - C

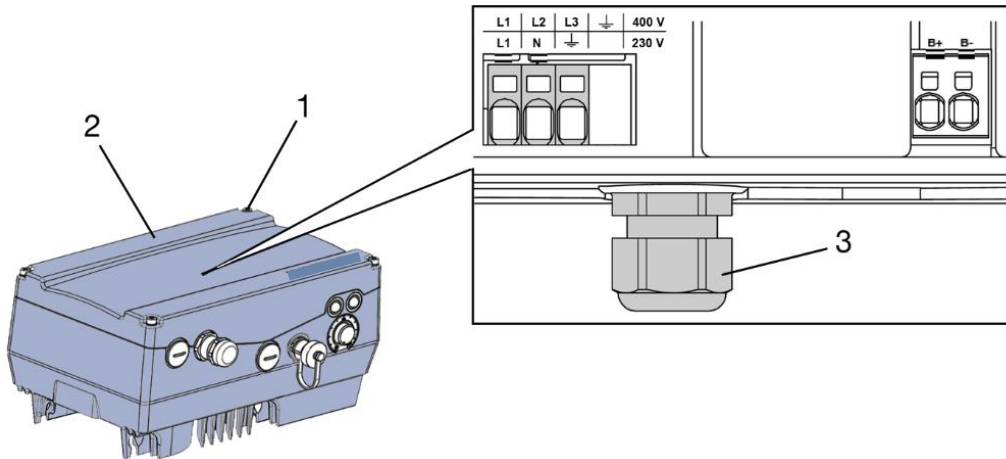

Fig. 10: Power connection sizes A - C



IMPORTANT INFORMATION

When connecting a brake resistor to an optional brake chopper, cables with shielding and double insulation must be used!



DANGER!

Risk of death due to electrical shock!

Death or serious injury!

De-energise drive controller and secure it against being restarted.

1. Unscrew the four screws (1) from the drive controller's housing cover (2) and then take it off.
2. Guide the mains connection cable through the cable glands (3).

Continues on next page

Continuation

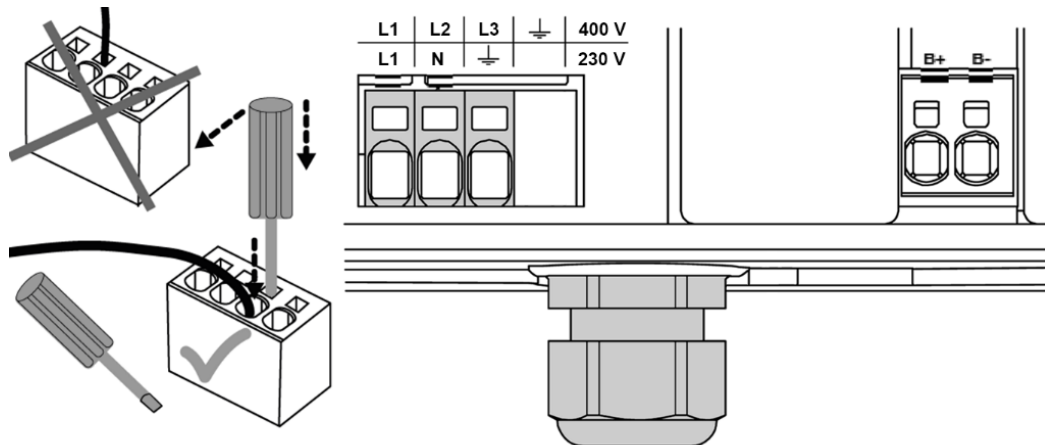

3. Connect the cables with the terminals as follows:

230 V connection			
L1		N	PE

400 V connection			
L1	L2	L3	PE

Terminal no.	Designation	Assignment
1	L1	Mains phase 1
2	L2	Mains phase 2
3	L3	Mains phase 3
4	PE	Protective conductor

Tab. 2: 3 x 400 VAC terminal assignment X1

Terminal no.	Designation	Assignment
1	L1	DC mains (+)
2	L2	Not assigned
3	L3	DC mains (-)
4	PE	Protective conductor

Tab. 3: DC feed 565 V terminal assignment X1

Terminal no.	Designation	Assignment
1	L1	Mains phase 1
2	N	Neutral wire
3	PE	Protective conductor

Tab. 4: 1 x 230 VAC terminal assignment X1

Continues on next page

1	2	3	4	5	6	7	8	9	10	11	12
---	---	---	---	---	---	---	---	---	----	----	----

Continuation

Terminal no.	Designation	Assignment
1	L1	DC mains (+)
2	N	DC mains (-)
3	PE	Protective conductor

Tab. 5: DC feed 325 V terminal assignment X1

Power connection for size D

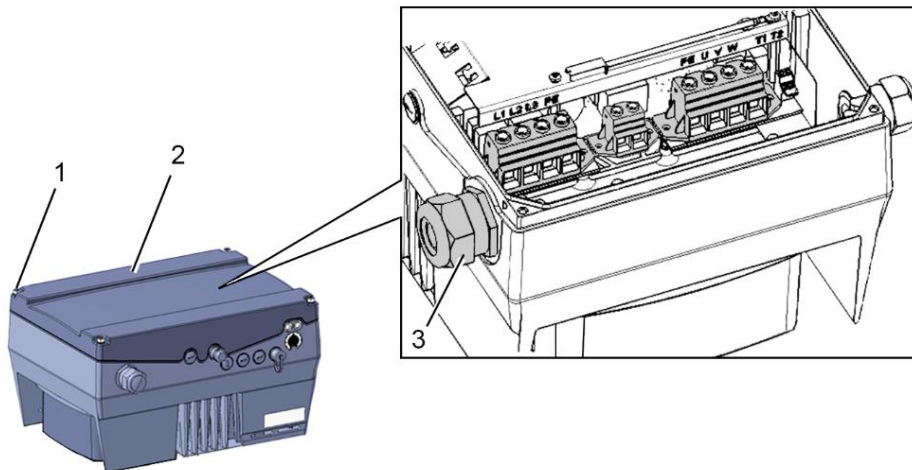

Fig. 11: Power connection for size D



IMPORTANT INFORMATION

When connecting a brake resistor to an optional braking module, cables with shielding and double insulation must be used!



DANGER!

Risk of death due to electrical shock!

Death or serious injury!

De-energise drive controller and secure it against being restarted.

1. Unscrew the four screws (1) from the drive controller's housing cover (2) and then take it off.
2. Guide the mains connection cable through the cable glands (3).



IMPORTANT INFORMATION

The cable screw connection provides strain relief, and the PE connection cable must be connected in a leading fashion (considerably longer).

Continues on next page

1	2	3	4	5	6	7	8	9	10	11	12
---	---	---	---	---	---	---	---	---	----	----	----

Continuation

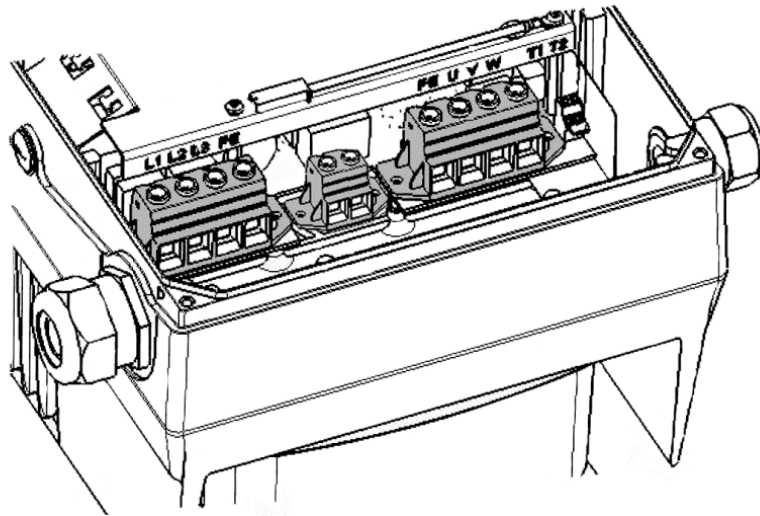

3. Connect the cables with the terminals as follows:

400 V connection			
L1	L2	L3	PE

Terminal no.	Designation	Assignment
1	L1	Mains phase 1
2	L2	Mains phase 2
3	L3	Mains phase 3
4	PE	Protective conductor

Tab. 6: 3 x 400 VAC terminal assignment X1

The protective conductor must be connected to the "PE" contact.

Terminal no.	Designation	Assignment
1	L1	DC mains (+)
2	L2	Not assigned
3	L3	DC mains (-)
4	PE	Protective conductor

Tab. 7: DC feed 565 V terminal assignment X1

Terminal no.	Designation	Assignment
1	PE	Protective conductor
2	U	Motor phase 1
3	V	Motor phase 2
4	W	Motor phase 3

Tab. 8: Motor connection assignment X4

1	2	3	4	5	6	7	8	9	10	11	12
---	---	---	---	---	---	---	---	---	----	----	----

3.4.2 Connections for brake resistor

Terminal no.	Designation	Assignment
1	B+	Connection for brake resistor (+)
2	B -	Connection for brake resistor (-)

Tab. 9 Optional terminal assignment for brake chopper

3.4.3 Control connections X5, X6, X7

Control connections of the standard application board

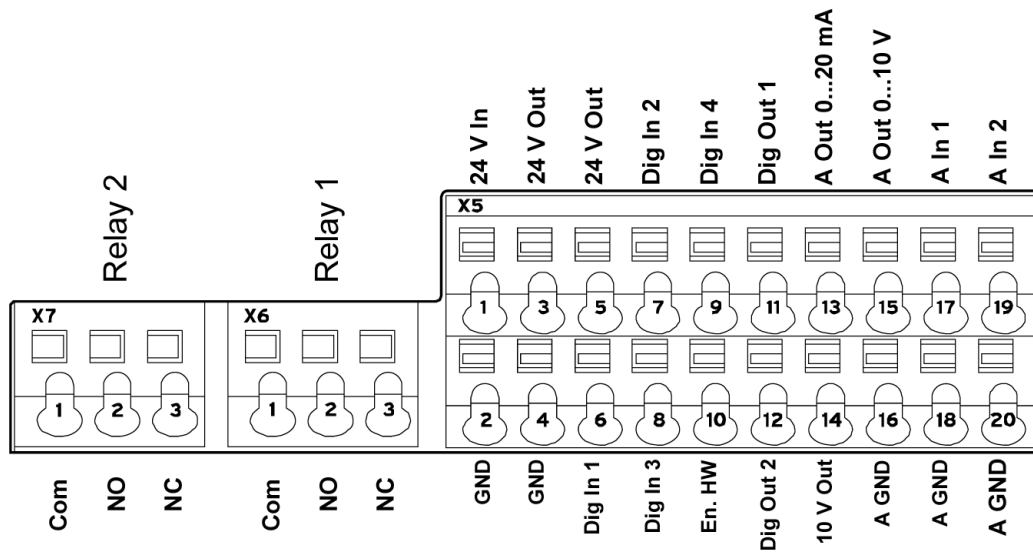

Fig. 12: Control connections of the standard application board



IMPORTANT INFORMATION

Danger of external signals being coupled in.
Use only shielded control line!

1. Guide the required control cable into the housing through the cable screw connections.
2. Connect the control cables according to the figure and/or table. Use shielded control cables.
3. Place the cover on the housing of the drive controller and bolt it tight to the following torque.

Size.	Torque
A - C	2 Nm (4 x M4 x 28)
D	4 Nm (4 x M6 x 28)

Continues on next page



Continuation

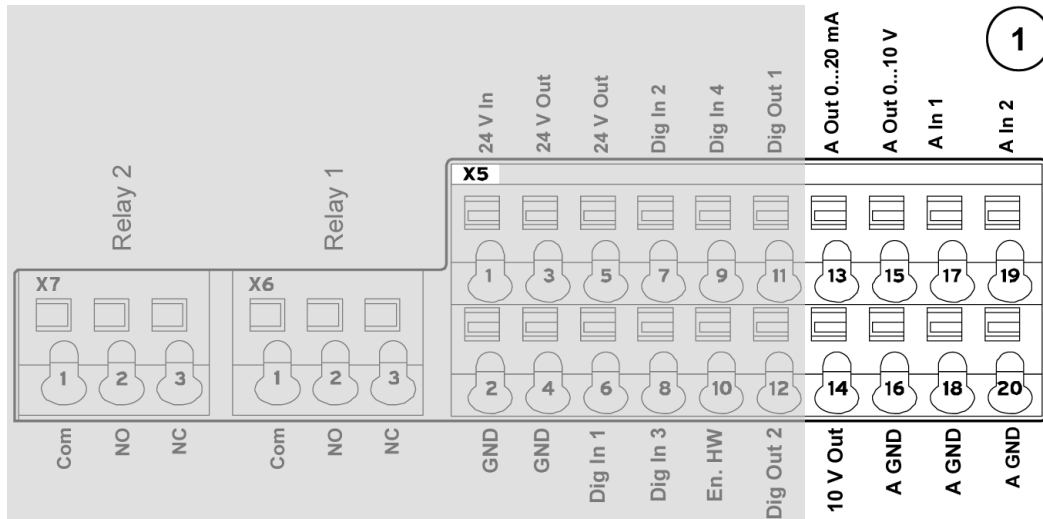

(see also 3.4.4 connection diagram)

Terminal no.	Designation	Assignment
13	A. Out 0 ... 20 mA	Actual frequency value (parameter 4.100)
14	10 V Out	For ext. voltage divider
15	A. Out 0 ... 10 V	Actual frequency value (parameter 4.100)
16	A GND (ground 10 V)	Ground
17	A. In 1	PID actual value (parameter 3.060)
18	A GND (Ground 10 V)	Ground
19	A. In 2	Free (not assigned)
20	A GND (ground 10 V)	Ground

Tab. 10: Terminal assignment X5 of the standard application board

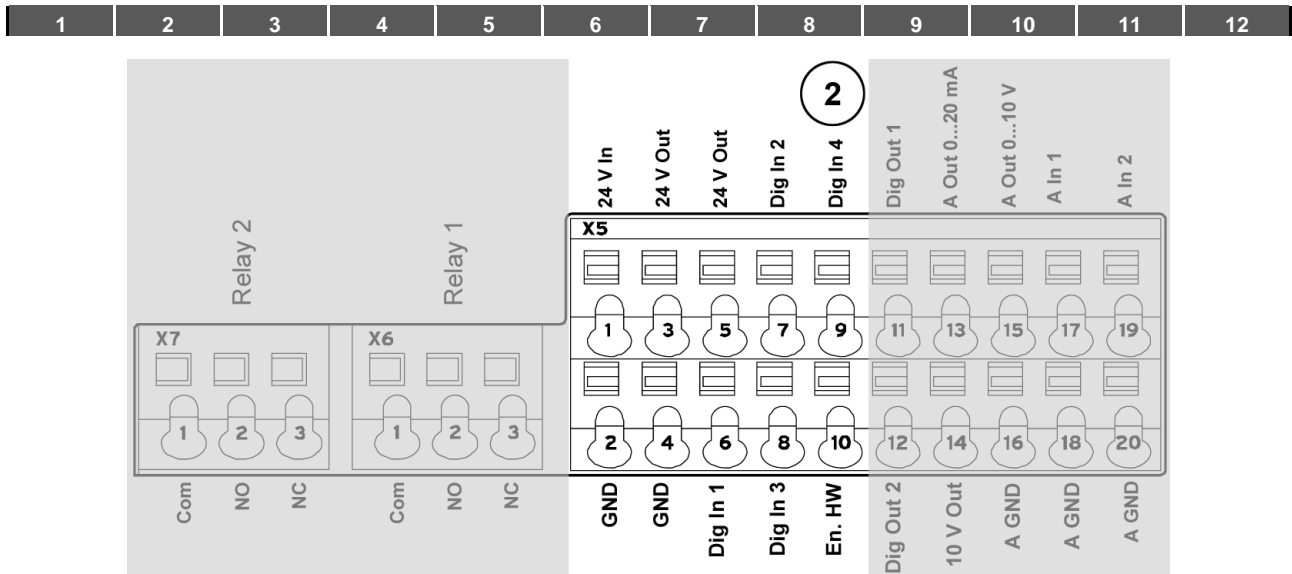

(see also 3.4.4 connection diagram)

Terminal no.	Designation	Assignment
1	24 V In	Ext. power supply
2	GND (ground)	Ground
3	24 V Out	Int. power supply
4	GND (ground)	Ground
5	24 V Out	Int. power supply
6	Dig. In 1	Target value enable (parameter 1.131)
7	Dig. In 2	Free (not assigned)
8	Dig. In 3	Free (not assigned)
9	Dig. In 4	Error reset (parameter 1.180)
10	En HW (enable)	Enable hardware

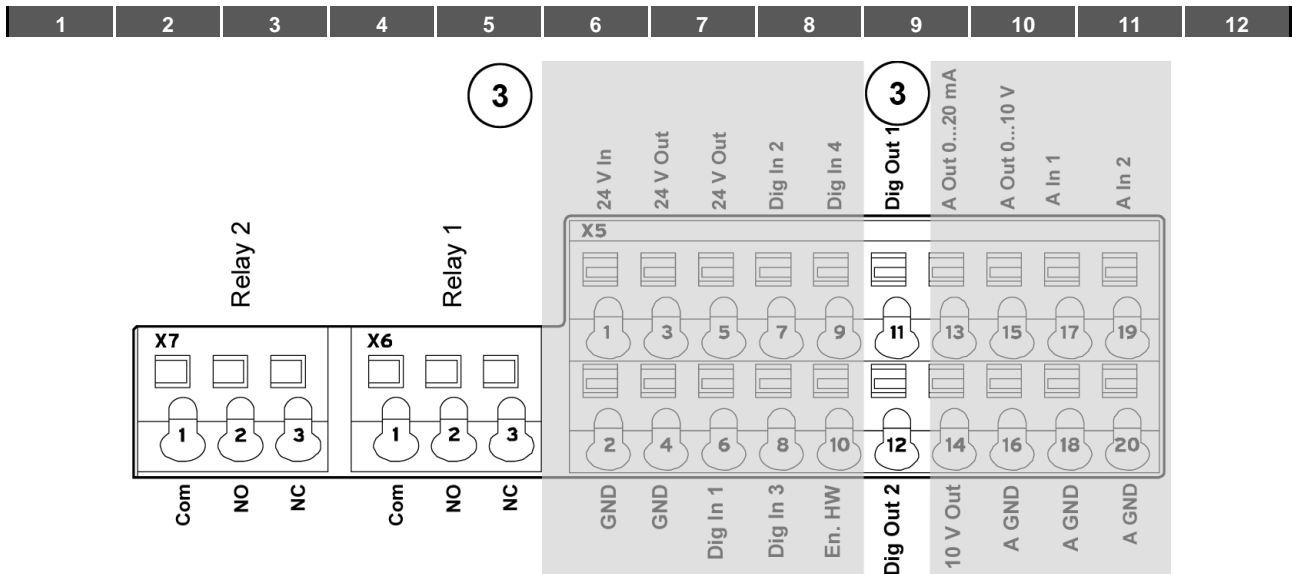

(see also 3.4.4 connection diagram)

Terminal no.	Designation	Assignment
11	Dig. Out 1	Fault message (parameter 4.150)
12	Dig. Out 2	Free (not assigned)

X6 relay 1

Terminal no.	Designation	Assignment
1	COM	Centre contact relay 1
2	NO	Normally open relay 1
3	NC	Normally closed relay 1

Tab. 11: Terminal assignment X6 (relay 1)

i **INFORMATION**
 In the factory setting, relay 1 is programmed as “relay error” (parameter 4.190).

X7 relay

Terminal no.	Designation	Assignment
1	COM	Centre contact relay 2
2	NO	Normally open relay 2
3	NC	Normally closed relay 2

Tab. 12: Terminal assignment X7 (relay 2)

i **INFORMATION**
 In the factory setting, “no function” is assigned to relay 2 (parameter 4.210).

1	2	3	4	5	6	7	8	9	10	11	12
---	---	---	---	---	---	---	---	---	----	----	----

Control connections of the basic application board

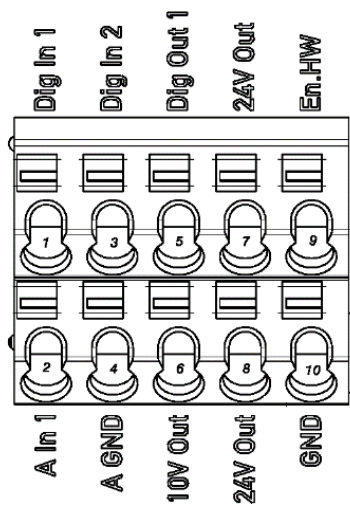

Fig. 13: Control connections of the basic application board

Terminal no.	Designation	Assignment
1	Dig. In 1	Target value enable (parameter 1.131)
2	A. In 1	Free (not assigned)
3	Dig. In 2	Free (not assigned)
4	A GND (ground 10 V)	Ground
5	Dig. Out	Fault message (parameter 4.150)
6	10 V Out	For ext. voltage divider
7	24 V Out	Int. power supply
8	24 V Out	Int. power supply
9	En HW (enable)	Enable hardware
10	GND (ground)	Ground



3.4.4 Connection diagram

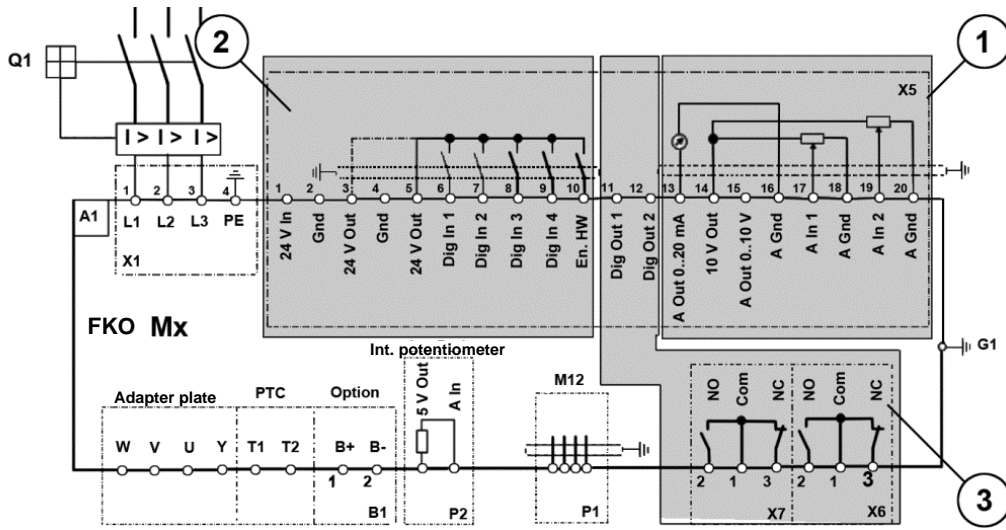

Fig. 14: Control connections

Characters	Explanation
A1	Drive controller type: FKO Mx IV01 (3 x 400 VAC)
B1	Connection for external brake resistor (option)
G1	M6 grounding screw (connection for residual currents > 3.5 mA)
P1	RS485 programming interface (M12 plug)
P2	Internal potentiometer
Q1	Motor protection switch or load break switch (optional)
X1	Mains terminals
X5 – X7	Digital/analogue inputs and outputs

The drive controller is ready once a 3 x 400 VAC mains supply has been activated (on terminals L1 to L3) or a 565 V DC mains supply has been activated (on terminals L1 and L3).

The drive controller can also be started up by connecting an external 24 V voltage.

1	2	3	4	5	6	7	8	9	10	11	12
---	---	---	---	---	---	---	---	---	----	----	----

3.5 Installing the wall-mounted drive controller

3.5.1 Suitable installation location for wall mounting

Ensure that the installation location for an FKO wall mounting meets the following conditions:

- The drive controller has to be mounted on an even and fixed surface.
- The drive controller may only be mounted on non-inflammable bases.
- There must be clearance of 200 mm around the drive controller to ensure free convection.

The following figure shows the assembly dimensions and the free spaces required for installing the drive controller.

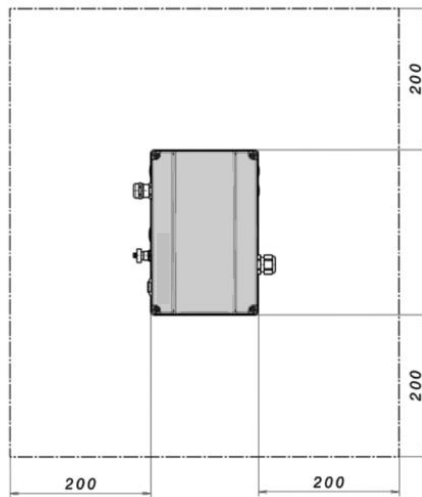

Fig. 15: Minimum clearances

For the "wall mounting" version, the following maximum line lengths are permissible between motor and FKO

FKO size	Max. length shielded	Max. length unshielded
A	5 m	5 m
B	5 m	5 m
C	20 m	100 m
D	20 m	100 m

(For exceptions, see chapter 1.2 EMC Limit Classes)



IMPORTANT INFORMATION

Only use shielded cables with the appropriate cross-section.
Establish a PE connection beneath the terminal board of the wall mounting!

1

2

3

4

5

6

7

8

9

10

11

12

3.5.2 Mechanical installation sizes A - C

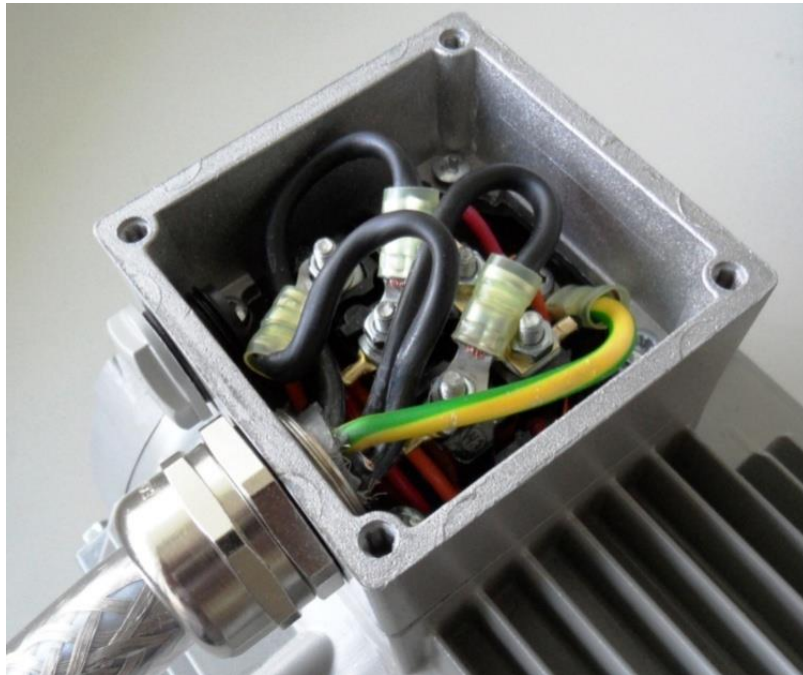

Fig. 16: Wiring on the motor connection box

1. Open the motor connection box.



IMPORTANT INFORMATION

Depending on the required motor voltage, the star or triangle connection must be made in the motor connection box!

2. Use suitable EMC screw connections to attach the shielded motor cables to the motor connection boxes! Ensure that the shielding contact is in order (large surface)!
3. Connect the prescribed PE connection in the motor connection box!
4. Close the motor connection box.

Continues on next page

1

2

3

4

5

6

7

8

9

10

11

12

Continuation

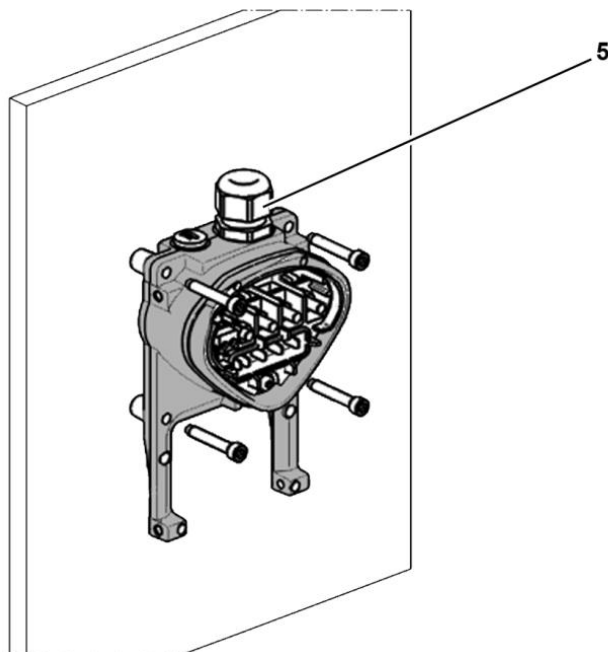

Fig. 17: Fastening the adapter plate to the wall



IMPORTANT INFORMATION

The drive controller may not be installed without an adapter plate!

- Find a position that meets the required ambient conditions described in the "[Installation requirements](#)" section.
- To achieve optimum self-convection of the drive controller, ensure that the (EMC) screw connection (5) is facing upwards during installation.
- If there is no additional ventilation for the FKO (optional for size C), only vertical installation is permitted.

Continues on next page

1	2	3	4	5	6	7	8	9	10	11	12
---	---	---	---	---	---	---	---	---	----	----	----

Continuation

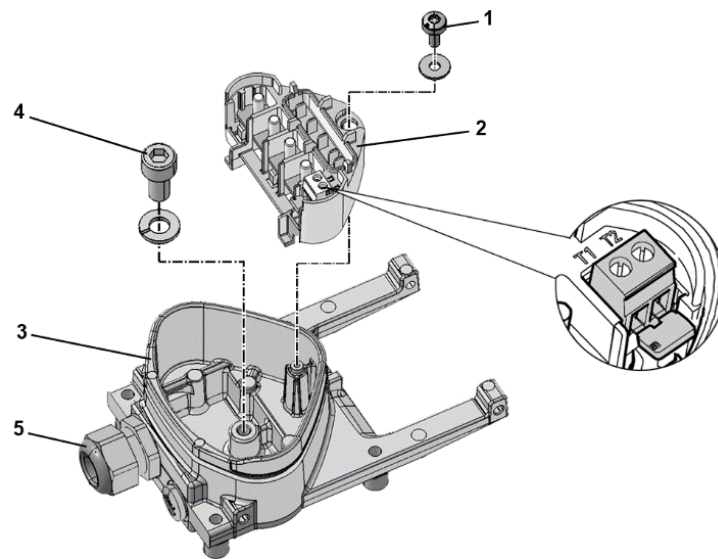

Fig. 18: Wiring

1. Release the screw (1) to remove the contact plate (2) from the adapter plate (3). The (M6 x 12) PE connection (4) is underneath the contact plate.
2. Guide the connection cable from the motor to the adapter plate (3) through the integrated EMC screw connection (5).
3. This PE connection (torque: 4.0 Nm) must be made to the same ground potential as the motor. The cross-section of the equipotential bonding line must correspond to at least the cross-section of the power cable.



DANGER!

**Risk of death due to electrical shock!
Death or serious injury!**

The drive controller must be grounded with the motor according to relevant regulations. The PE connection between the motor and drive controller should be established using the hexagon socket screw (4) and the spring ring included in the scope of supply for the adapter plate (3).

4. Refit the contact plate (2) in the adapter plate (3).
5. Fasten the contact plate (2) using the screw (1) (torque: 1.2 Nm).



INFORMATION

After fastening the contact plate (2), ensure that it is mounted floating.

Continues on next page

1

2

3

4

5

6

7

8

9

10

11

12

Continuation

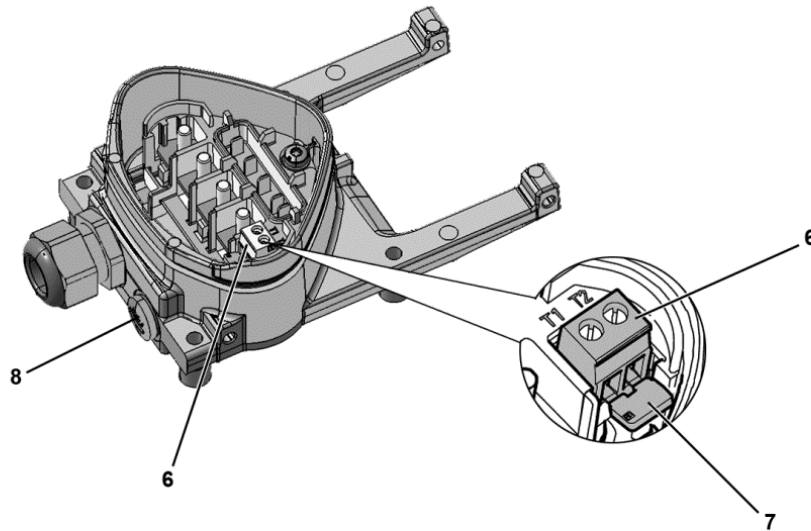

6. Wire the motor cable to contacts U, V, W (and the star point in some cases) in the connection terminal, as described in the "[Basic connection versions](#)" chapter. Use cable shoes (M5) to do this.
7. Before connecting an existing motor PTC to the T1 and T2 terminals (6), remove the pre-assembled short-circuit bridge (7).

DANGER!



Risk of death due to electrical shock!
Death or serious injury!

The motor PTC is energised once the FKO is connected, therefore it must be connected using a separate insulated motor lead. Only motor PTCs corresponding to DIN 44081/44082 may be connected!

Replace the dummy screw (8) with a suitable standard screw connection and guide both ends to T1 and T2 (6).

Continues on next page

1	2	3	4	5	6	7	8	9	10	11	12
---	---	---	---	---	---	---	---	---	----	----	----

Continuation

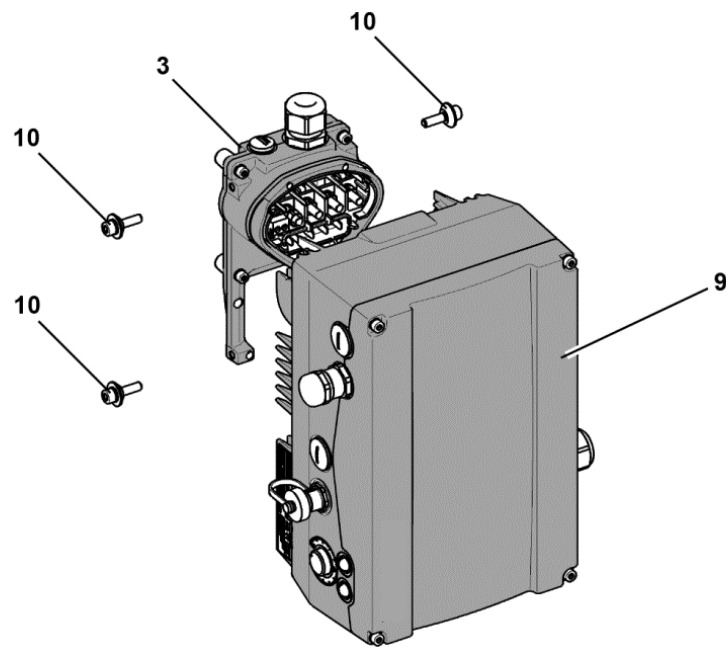

Fig. 19: Attaching the drive controller

8. Position the drive controller (9) on the adapter plate (3) so that the collar of the adapter dips into the opening on the floor of the cooling element.
9. Fasten the drive controller (9) to the adapter plate (3) with the help of the screws (10) provided (torque: 4.0 Nm).

1

2

3

4

5

6

7

8

9

10

11

12

3.5.3 Mechanical installation of size D



Fig. 20: Wiring on the motor connection box

1. Open the motor connection box.



IMPORTANT INFORMATION

Depending on the required motor voltage, the star or triangle connection must be made in the motor connection box!

2. Use suitable EMC screw connections to attach the shielded motor cables to the motor connection boxes! Ensure that the shielding contact is in order (large surface)!
3. Connect the prescribed PE connection in the motor connection box!
4. Close the motor connection box.

Continues on next page

1	2	3	4	5	6	7	8	9	10	11	12
---	---	---	---	---	---	---	---	---	----	----	----

Continuation

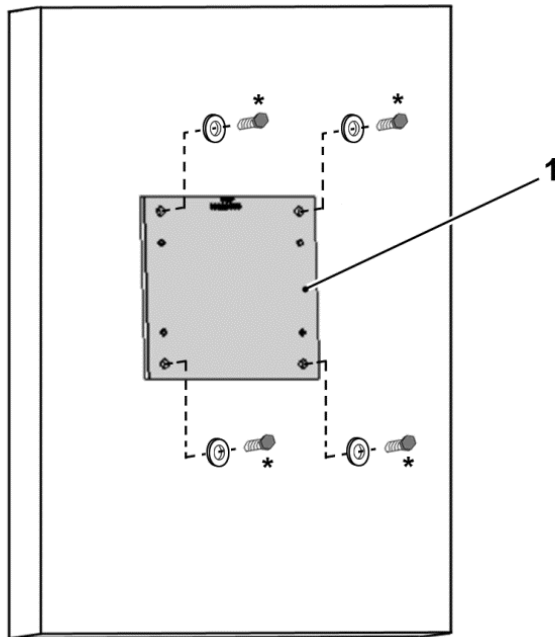

Fig. 21: Fastening adapter plate size D to the wall



IMPORTANT INFORMATION

IMPORTANT INFORMATION

The drive controller may not be installed without an adapter plate (1)!

- Find a position that meets the required ambient conditions described in the "Installation requirements" section.

5. Mount the adapter plate (1) on the wall with four screws*.

Continues on next page

* The screws are not part of the scope of delivery.

1	2	3	4	5	6	7	8	9	10	11	12
---	---	---	---	---	---	---	---	---	----	----	----

Continuation

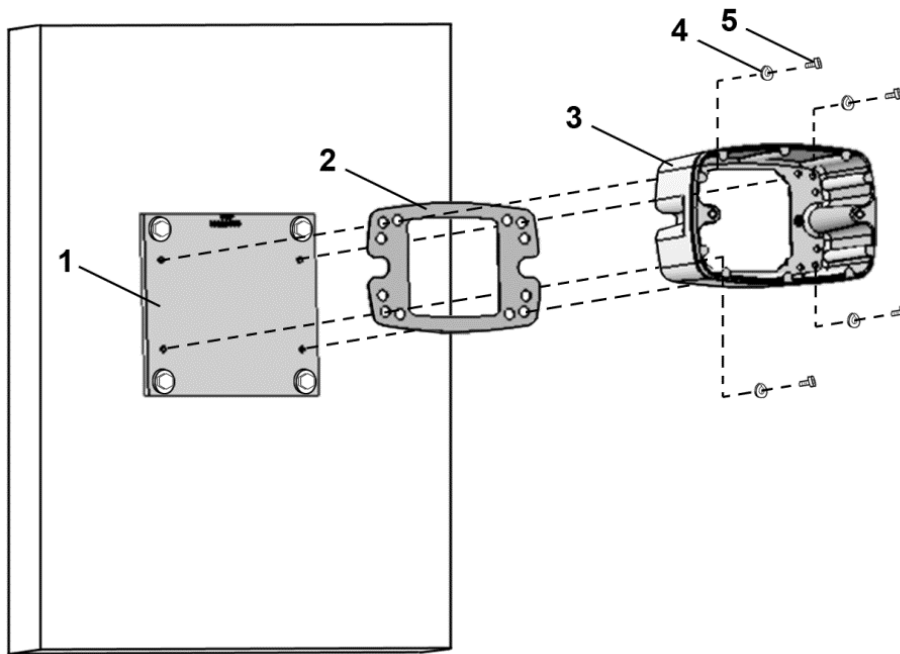

Fig. 22: Fastening the size D cup to the adapter plate

6. Mount seal (2), along with cup (3), to the adapter plate (1).
Use the retaining bolts (5) and spring elements (4) provided (torque 8.5 Nm).



IMPORTANT INFORMATION

Please ensure that the seal (2) sits perfectly!

Continues on next page

Continuation

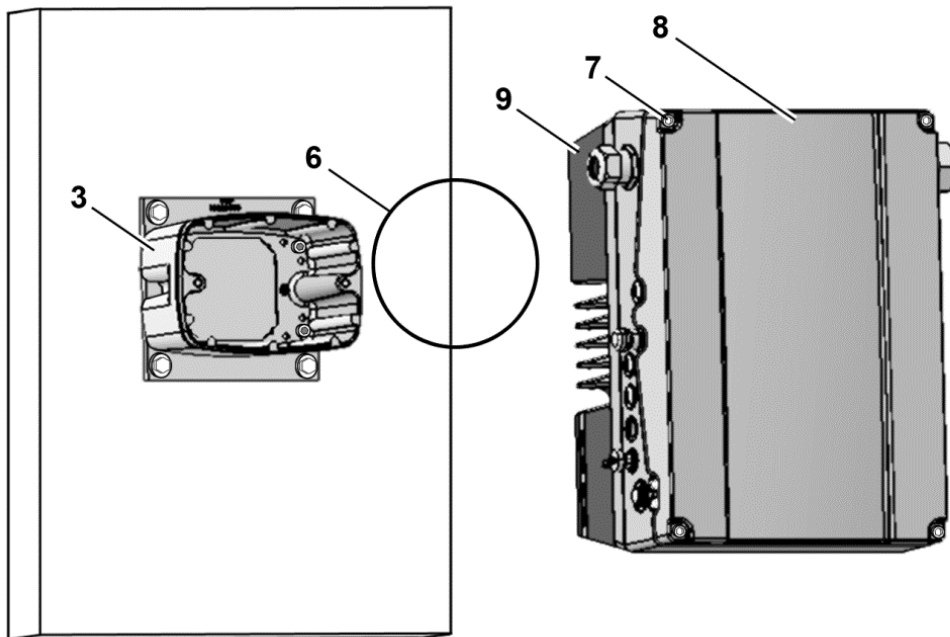

Fig. 23: Inserting O-ring seal size D

7. Insert the O-ring seal (6) in the groove of the cup (3).



IMPORTANT INFORMATION

Please ensure that the O-ring seal (6) sits perfectly!

8. Unscrew the four screws (7) from the cover (8) of the drive controller (9).
9. Take off the cover (8).

Continues on next page

1	2	3	4	5	6	7	8	9	10	11	12
---	---	---	---	---	---	---	---	---	----	----	----

Continuation

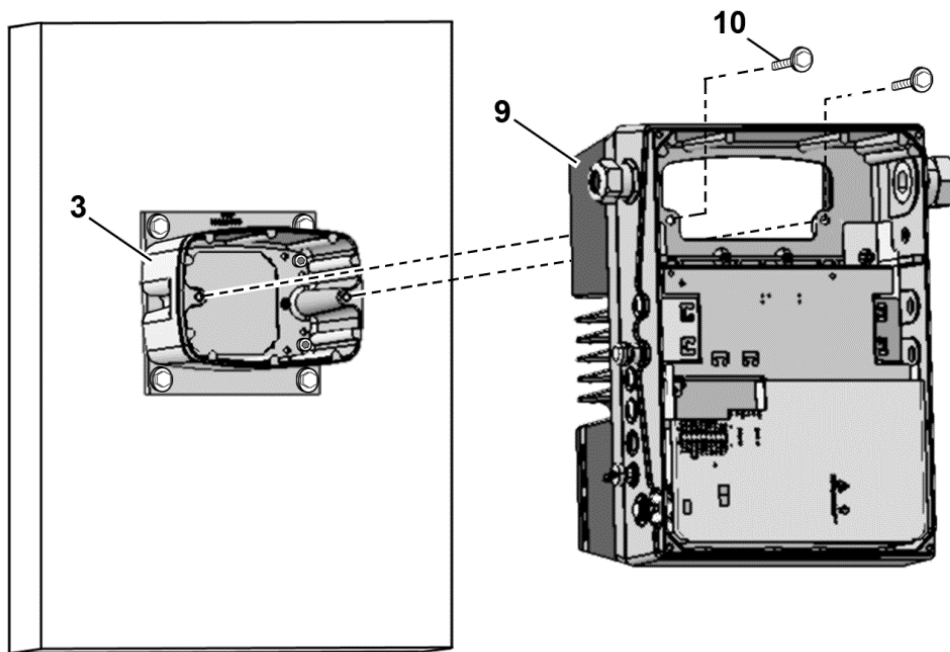

Fig. 24: Fastening drive controller to size D cup

10. Carefully place the drive controller (9) onto the cup (3).
11. Screw down both parts uniformly with the two M8 screws (10) (torque: max. 25 Nm).

Continues on next page

Continuation

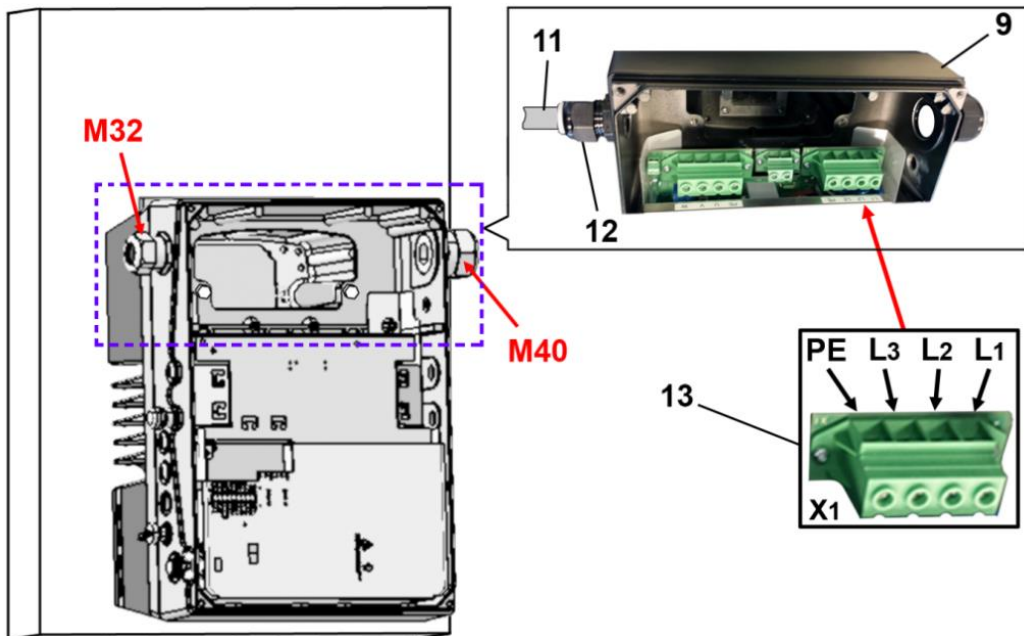

Fig. 25: Mains connection size D

12. Guide mains connection cable (11) through cable screw connection (12) [M32] into drive controller (9).



IMPORTANT INFORMATION

The cable screw connection provides strain relief, and the PE connection cable must be connected in a leading fashion (considerably longer).

13. Connect the cables with the terminals [X1] (13) as follows:

400 V connection			
L1	L2	L3	PE

The protective conductor must be connected to the "PE" contact.

Terminal no.	Designation	Assignment
1	L1	Mains phase 1
2	L2	Mains phase 2
3	L3	Mains phase 3
4	PE	Protective conductor

Tab. 13: 3~ 400 V terminal assignment X1

Continues on next page

1	2	3	4	5	6	7	8	9	10	11	12
---	---	---	---	---	---	---	---	---	----	----	----

Continuation

Terminal no.	Designation	Assignment
1	L1	DC mains (+)
2	L2	Not assigned
3	L3	DC mains (-)
4	PE	Protective conductor

Tab. 14: DC feed 565 V terminal assignment X1

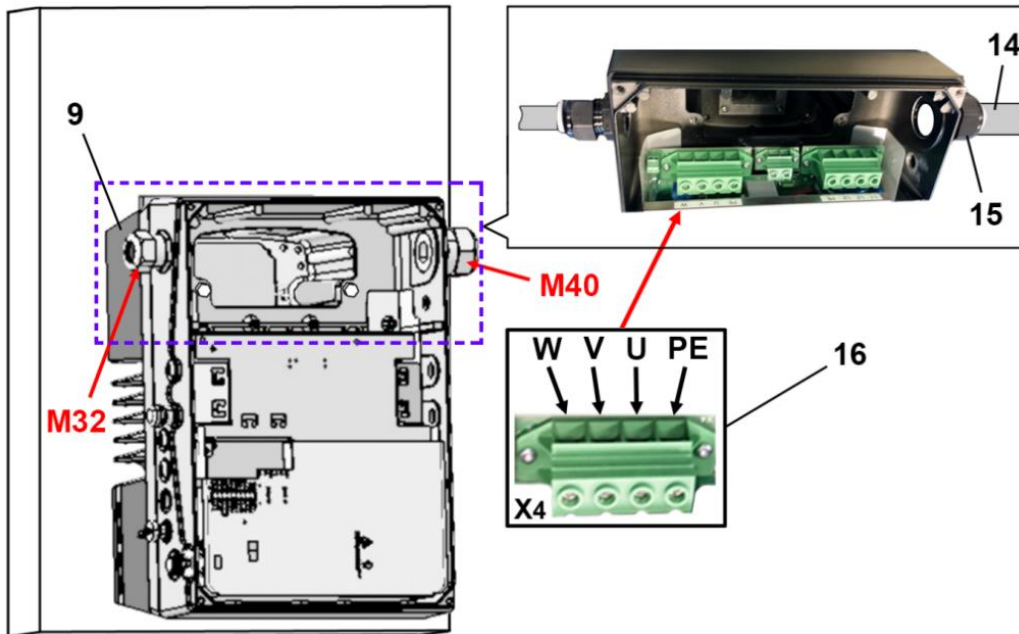

Fig. 26: Motor connection size D

14. Guide motor connection cable (14) through cable screw connection (15) [M40] into drive controller (9).



IMPORTANT INFORMATION

The cable screw connection provides strain relief, and the PE connection cable must be connected in a leading fashion (considerably longer).

15. Connect the cables with the terminals [X4] (16) as follows:

Terminal no.	Designation	Assignment
1	PE	Protective conductor
2	U	Motor phase 1
3	V	Motor phase 2
4	W	Motor phase 3

Tab. 15: Motor connection assignment X4

Continues on next page

1	2	3	4	5	6	7	8	9	10	11	12
---	---	---	---	---	---	---	---	---	----	----	----

Continuation

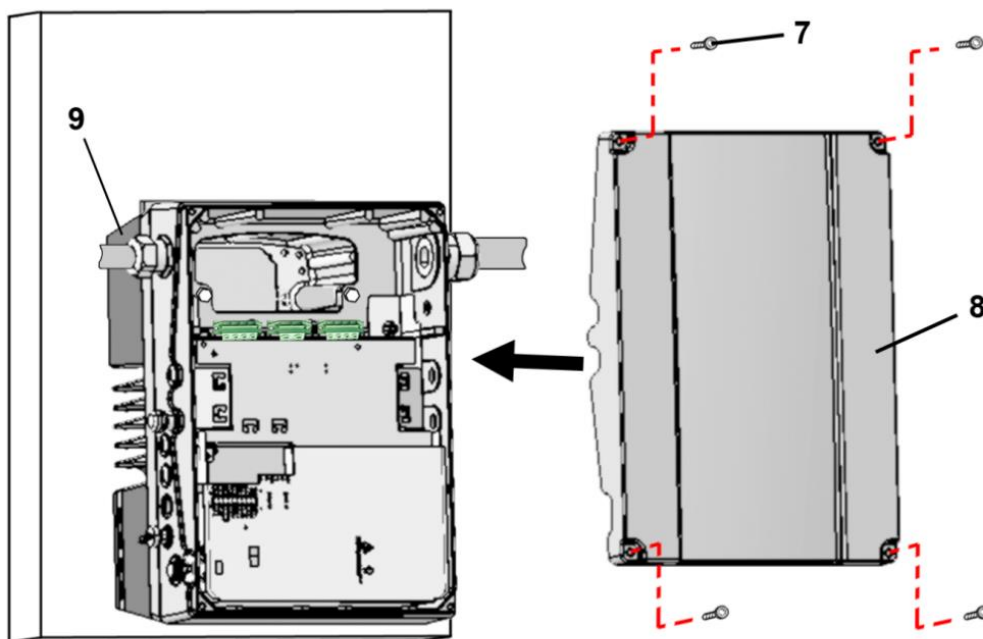

Fig. 27: Closing housing size D

16. Place cover (8) on housing of drive controller (9).
17. Screw down both parts with the four screws (7) (torque 4 Nm).

3.5.4 Power connection

The power connections should be designed as described in section 3.4 ff. "[Installing the drive controller integrated in the motor](#)".

3.5.5 Brake chopper

The brake connections should be designed as described in section 3.4. 3 ff. "[Connections for brake resistor](#)".

3.5.6 Control connections

The control connections should be designed as described in section 3.4 ff. "[Installing the drive controller integrated in the motor](#)".

1	2	3	4	5	6	7	8	9	10	11	12
---	---	---	---	---	---	---	---	---	----	----	----

3.6 Disassembly and assembly of the FKO fan, size "D"

Below you will find a description of how to replace the size "D" fan on the FKO. For your own safety, be sure to observe the safety notices and information provided.

DANGER!



Risk of death due to fire or electrical shock!
Death or serious injury!

De-energise drive controller and secure it against being restarted.
 Only allow appropriately qualified staff to undertake disassembly and assembly.
 Only use staff who are trained in mounting, installation, commissioning and handling.
 Always ground the device in accordance with DIN EN 61140; VDE 0140, NEC and other relevant standards.

3.6.1 Fan disassembly

DANGER!



Risk of death due to electrical shock!
Death or serious injury!

De-energise drive controller and secure it against being restarted.



Danger due to electrical shock and discharge. Wait two minutes (discharge time of the capacitors) after shut-down.

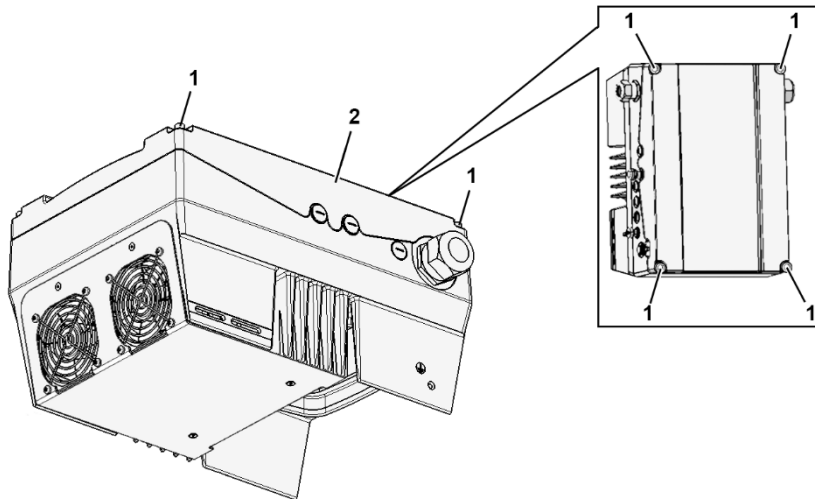

Fig. 28: Disassembly of fan, size D

1. Unscrew the four screws (1) from the cover (2) of the drive controller.
2. Take off the cover (2) of the drive controller.

Continues on next page

1	2	3	4	5	6	7	8	9	10	11	12
---	---	---	---	---	---	---	---	---	----	----	----

Continuation

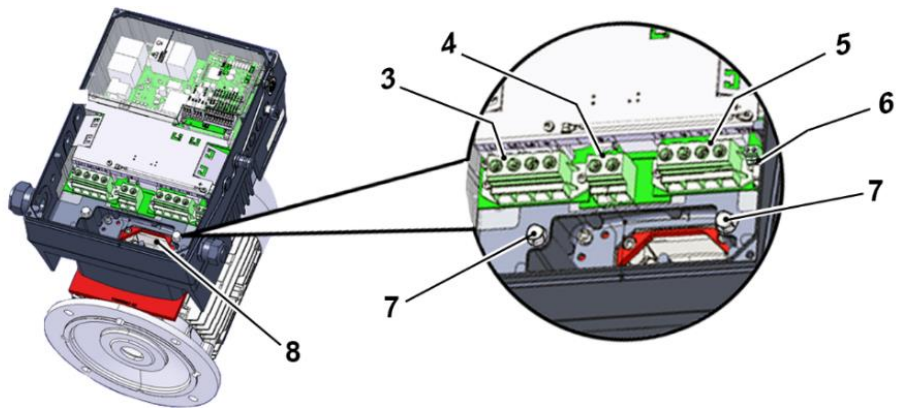

DANGER!

 Risk of death due to electrical shock!
 Death or serious injury!
 De-energise drive controller and secure it against being restarted.

3. Disconnect the wires from the following connections:
 - (3) "Mains terminal [X1]",
 - (4) "Brake resistor [X2] (optional)",
 - (5) "Motor terminal [X4]",
 - (6) "Motor PTC/Klixon [X11]".
4. Unscrew both screws (7).
5. Carefully lift the drive controller off the cup (8) and place on a clean, level surface.

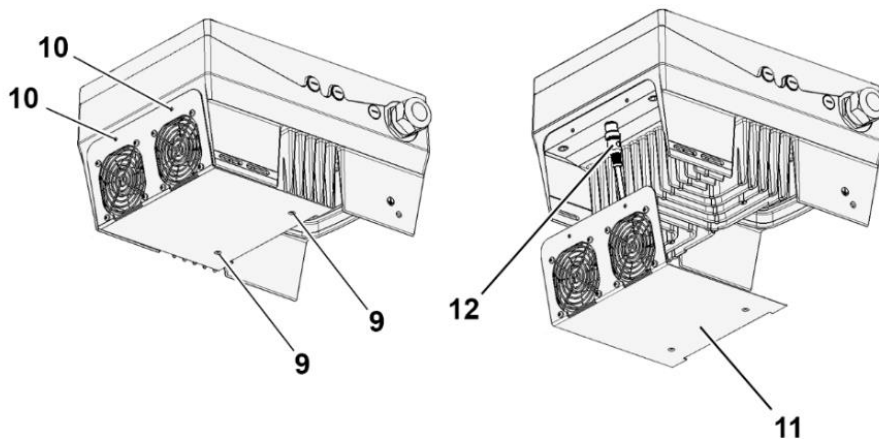

Fig. 29: Disassembly/assembly of fan, size D

6. Unscrews the screws (9) and (10).
7. Carefully release fan unit (11) from drive controller.
8. Disconnect the M12 plug (12).

1	2	3	4	5	6	7	8	9	10	11	12
---	---	---	---	---	---	---	---	---	----	----	----

3.6.2 Fan assembly

1. Plug M12 plug (12) of new fan unit (11) onto socket on drive controller.
2. Insert new fan unit (11) in drive controller and screw together with screws (9) and (10).

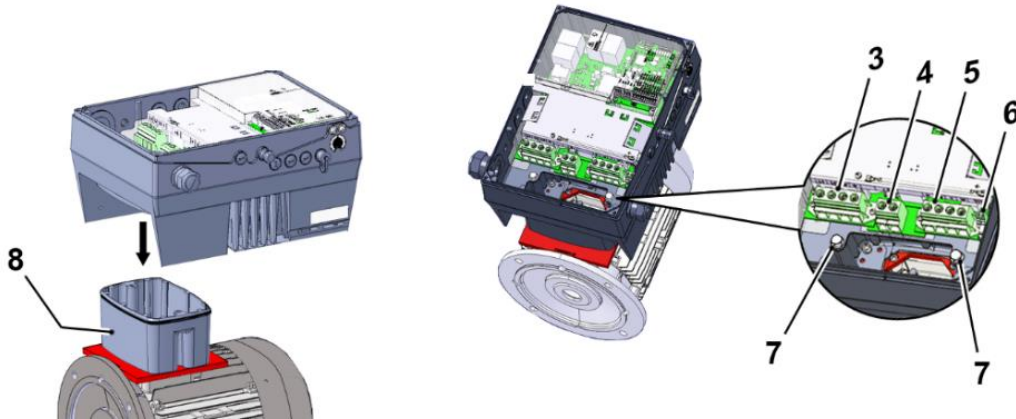

IMPORTANT INFORMATION

When placing the drive controller on the cup (8), ensure that seal (13) sits perfectly!

3. Carefully attach the drive controller to the cup (8) and secure uniformly with both M8 screws (7) (torque: max. 25.0 Nm).



DANGER!

Risk of death due to electrical shock!

Death or serious injury!

De-energise drive controller and secure it against being restarted.

4. Connect all cables to the following connections:
 - (3) "Mains terminal [X1]"
(see chapter 3.3.2 "Power connection/size D")
 - (4) "Brake resistor [X2] (optional)"
(see chapter 3.3.3)
 - (5) "Motor terminal [X4]"
(see chapter 3.3.2 "Power connection/size D")
 - (6) "Motor PTC/Klixon [X11]" (optional)

Continues on next page

Continuation

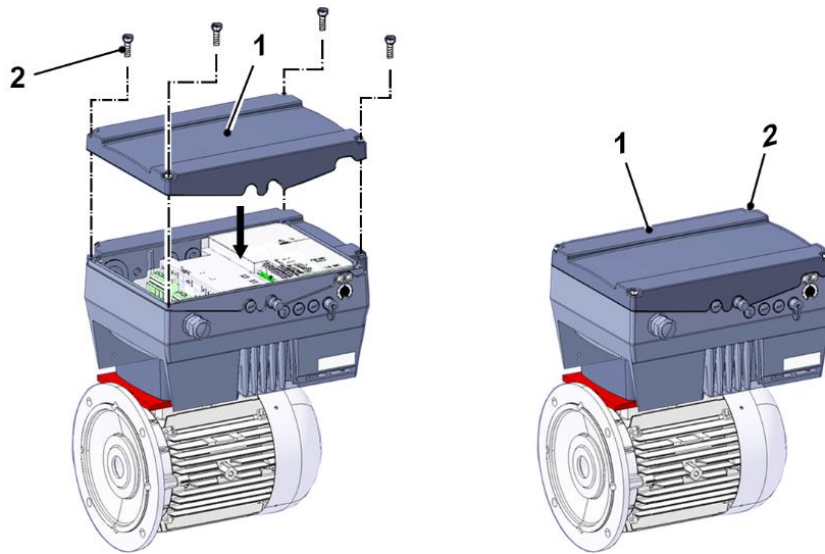

5. Place cover (1) on housing of drive controller.
6. Screw down both parts with the four screws (2) (torque: 4 Nm).

4. Commissioning

4.1 Safety instructions for commissioning



DAMAGE TO PROPERTY POSSIBLE

If the information is not observed, the drive controller could be damaged and destroyed during subsequent commissioning.

Commissioning may only be performed by qualified staff. Safety precautions and warnings must always be observed.



DANGER!

Risk of death due to electrical shock! Death or serious injury!

Be sure that the power supply provides the correct voltage and is designed for the required current.

Use suitable circuit breakers with the prescribed nominal current between the mains and drive controller.

Use suitable fuses with appropriate current values between the mains and drive controller (see technical data).

The drive controller must be grounded with the motor according to relevant regulations. Non-compliance may result in serious injury.

1	2	3	4	5	6	7	8	9	10	11	12
---	---	---	---	---	---	---	---	---	----	----	----

4.2 Communication

The drive controller can be commissioned in the following ways:

- using the FKOpC PC software



Fig. 30: PC software – start screen

- using the FKO MMI handheld controller*

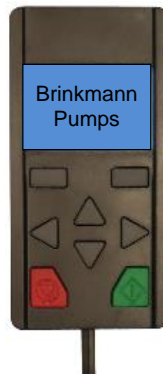

Fig. 31: MMI handheld controller

- using the MMI* in the cover (option)

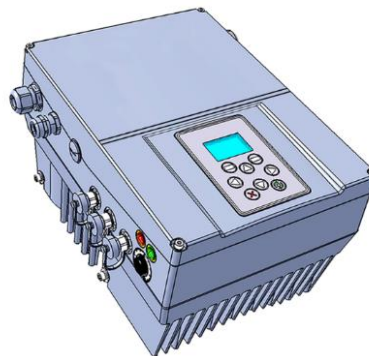

Fig. 32: MMI option

Continues on next page

* **Man-machine interface**

1	2	3	4	5	6	7	8	9	10	11	12
---	---	---	---	---	---	---	---	---	----	----	----

4.3 Block diagram

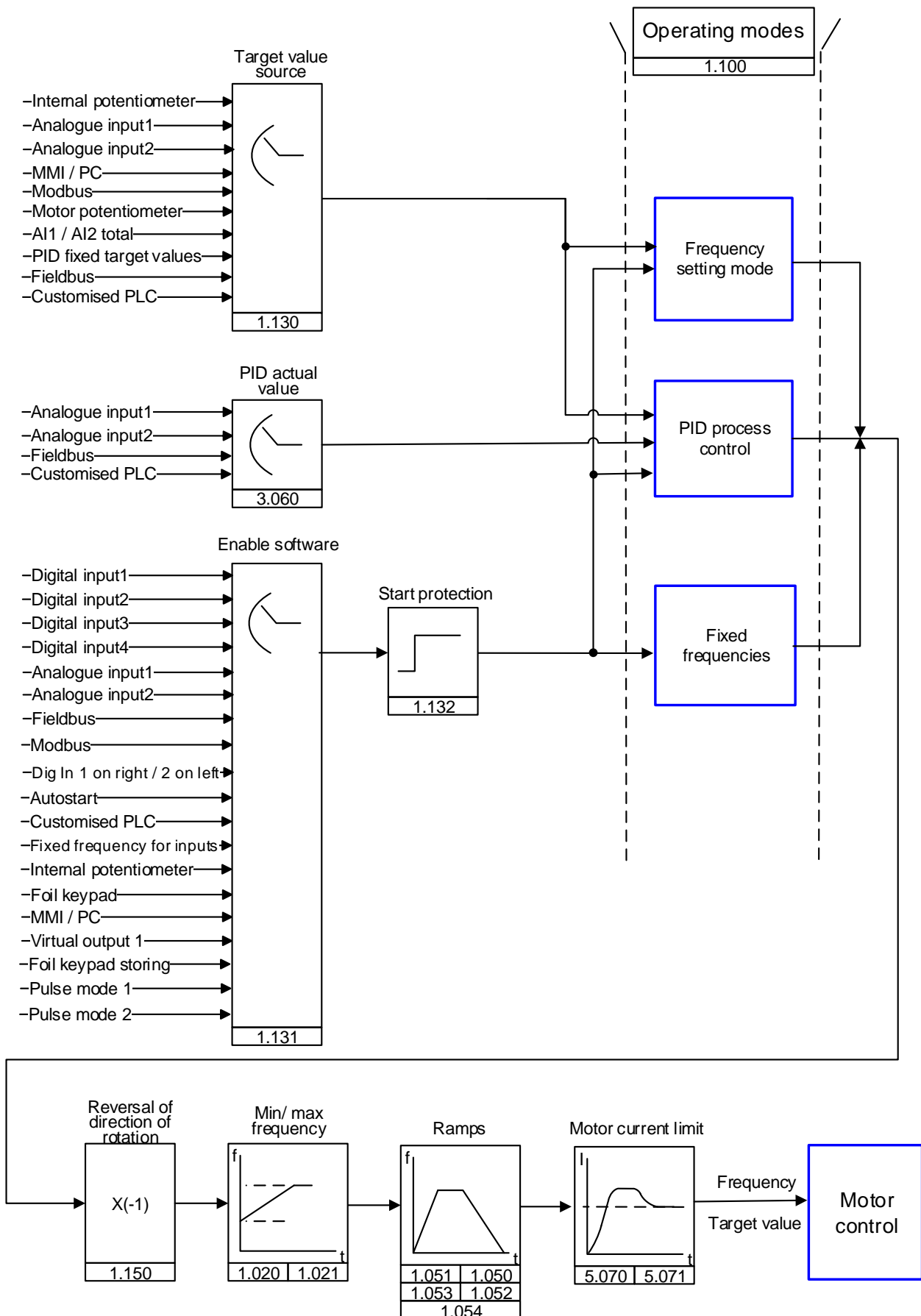

Fig. 33: General structure of target value generation

1

2

3

4

5

6

7

8

9

10

11

12

4.4 Commissioning steps



INFORMATION

Parameterisation is possible prior to device installation!

Parameterisation can be performed before the drive controller is installed in the motor.

The drive control has a 24 V low-voltage input for this purpose, which can supply the electric system without requiring mains power.

The commissioning can be performed using a PC communication cable USB at M12 plug with integrated interface converter RS485/RS232 (part no. 10023950) or using the FKO handheld controller MMI with connection cable RJ9 at M12 plug (part no. 10004768).

4.4.1 Commissioning using the PC:

1. Install the FKOPc software (you can obtain programming software from BRINKMANN free of charge).
Operating system required: Windows XP or Windows 7 [32 / 64 bit].
We recommend undertaking the installation process as an administrator.
2. Connect the PC to the M12 plug M1 with the optional connection cable.
3. Load or determine the motor data record (parameters 33.031 to 33.050); it may be necessary to optimise the speed control (parameters 34.090 to 34.091).
4. Perform the application settings (ramps, inputs, outputs, target values etc.).
5. Optional: Define an access level (1 – MMI, 2 – user, 3 – manufacturer).

See Fig. of block diagram in chapter
Quickstart guide [11](#)

In order to ensure an ideal operating structure for the PC software, the parameters are classified into different access levels.

The following levels exist:

1. handheld controller: – the drive controller is programmed using the handheld controller.
2. user: – the basic parameters can be programmed into the drive controller using the PC software.
3. Manufacturer: - an extended selection of parameters can be programmed into the drive controller using the PC software.

1

2

3

4

5

6

7

8

9

10

11

12

4.4.2 Commissioning using PC, combined with MMI option

1. Install the FKOpC software (you can obtain programming software from BRINKMANN free of charge).
Operating system required: Windows XP or Windows 7 [32 / 64 bit].
We recommend undertaking the installation process as an administrator.
2. Connect the PC to the M12 plug M1 with the optional connection cable.



IMPORTANT INFORMATION

After the power on the drive controller has been switched on, the diagnosis interface (M12 PC/MMI) is initially inactive.

To activate this interface, the "MMI option" has to be put into standby mode.

To do this, simultaneously press buttons (1) and (2) for approx. 1.5 sec.

"Standby" appears in the MMI display and internal communication is interrupted for 25 sec.



If communication for the FKOpC tool is established within 25 sec., the "MMI option" remains in standby mode.

Data can now be exchanged with the PC and/or an external MMI.

If communication is aborted or cannot be established within 25 sec., the "MMI option" switches from standby mode to normal mode.

Turning the display 180°

Depending on how the FKO is installed within the system, the display may have to be turned 180°.

You can turn the display 180° using parameter 5.200

by setting the parameter value to "1"

Continues on next page

Continuation



INFORMATION

The display is only turned 180° once the "Disconnect" button has been pressed in the "FKOpc tool".

Alternatively, the display can also be turned 180° in "normal mode".

To do this, simultaneously press buttons (3) and (4) for approx. 1.5 sec.

The display and functional button assignment are turned 180°.



5. Parameter

This chapter contains the following:

- an introduction to the parameters
- an overview of the most important commissioning and operation parameters

5.1 Safety instructions for working with parameters

DANGER!



Risk of death due to restarting motors!

Death or serious injury!

Non-observance may result in death, serious injury or damage.

Certain parameter settings and changing parameter settings during operation may result in the FKOPC drive controller restarting automatically after the supply voltage has failed, or in undesirable changes in the operating behaviour.



INFORMATION

If parameters are changed while the device is in operation, it may take a few seconds for the effect to become noticeable.

Fehler! Verweisquelle	Fehler! Verweisquelle	Fehler! Verweisquelle	Fehler! Verweisquelle	Fehler! Verweisquelle	Fehler! Verweisquelle	Fehler! Verweisquelle	Fehler! Verweisquelle
--------------------------	--------------------------	--------------------------	--------------------------	--------------------------	--------------------------	--------------------------	--------------------------

5.2 General information on parameters

5.2.1 Explanation of operating modes

The operating mode is the instance in which the target value is generated.

In the case of frequency setting mode, this is a simple conversion of the raw input target value into a rotation speed target value. In the case of PID process control, the target value and actual value are compared and the system then regulates to a specific process variable.

Frequency setting mode:

The target values from the "target value source" (1.130) are rescaled into frequency target values.

0 % is the "minimum frequency" (1.020).

100 % is the "maximum frequency" (1.021).

The target value's plus or minus sign is the decisive factor in rescaling.

PID process control:

The target value for the PID process controller is read in percentage steps as in the "frequency setting mode". 100 % corresponds to the working range of the connected sensor, which is read in via the actual value input (selected by the "PID actual value").

Depending on the control difference, a rotation speed value is output to the control output with the help of the amplification factors for the proportional gain (3.050), integral gain (3.051) and derivative gain (3.052).

In order to prevent the integral share from increasing infinitely in the case of uncontrollable control differences, this value is limited to a specific set value (corresponding to the "maximum frequency" (1.021)).

PID inverted:

The PID actual value can be inverted using parameter 3.061. The actual value is imported inversely, i.e. 0 V...10 V correspond internally to 100%...0%.

Please note that the target value must also be defined inversely.

An example:

A sensor with an analogue output signal (0 V...10 V) is to operate as the source of the actual value (at Alx). At an output variable of 7 V (70 %), this is to be regulated inversely. The internal actual value then corresponds to $100\% - 70\% = 30\%$.

In other words, the target value to be specified is 30 %.

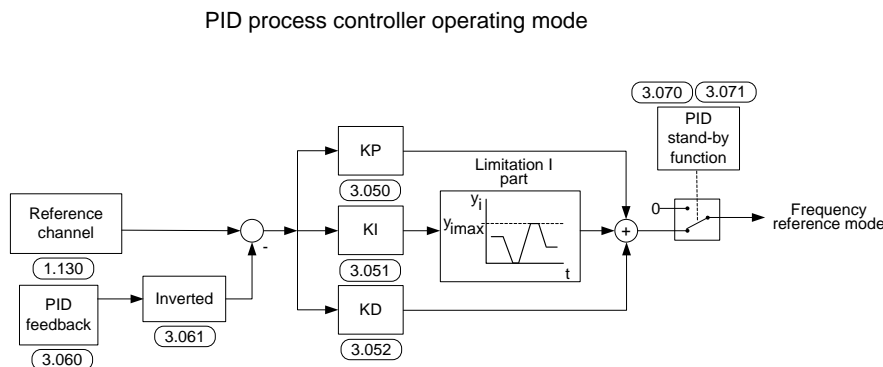

Fig. 34: PID process control

1	2	3	4	5	6	7	8	9	10	11	12
---	---	---	---	---	---	---	---	---	----	----	----

Stand-by function in PID process control

This function can provide energy savings in applications such as booster stations where PID process control is used to control to a specific process value and the pump has to run at a "minimum frequency" (1.020). As the drive controller can reduce the rotation speed of the pump in normal operation when the process variable is reducing, but it can never fall below the "minimum frequency" (1.020), this provides an opportunity for stopping the motor if it is running during a waiting time, the "PID stand-by time" (3.070) with the "minimum frequency" (1.020).

Once the actual value deviates from the target value by the set % value, the "PID stand-by hysteresis" (3.071), the control (the motor) is started again.

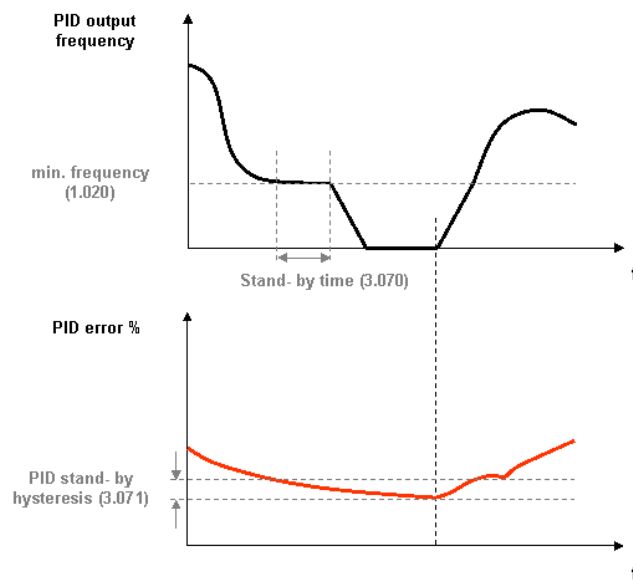

Fig. 35: Stand-by function in PID process control

1	2	3	4	5	6	7	8	9	10	11	12
---	---	---	---	---	---	---	---	---	----	----	----

Fixed frequency

This operating mode controls the drive controller with up to 7 fixed target values.

These are selected under parameter 2.050, where you can select how many fixed frequencies are to be used.

Parameter	Name	Selection options	Function	Number of digital inputs needed
2.050	Fixed frequency/mode	0	1 fixed frequency	1
		1	3 fixed frequencies	2
		2	7 fixed frequencies	3
	Foil keypad <small>(option)</small>	3	2 fixed frequencies	-
	Foil keypad <small>(option)</small>	4	2 fixed frequencies	-

Depending on the number of fixed frequencies required, up to 3 digital inputs are permanently assigned in the table.

Parameter	Name	Presetting	DI 3	DI2	DI1
1.020	Min. frequency	0 Hz	0	0	0
2.051 to 2.057	Fixed frequency 1	10 Hz	0	0	1
2.051 to 2.057	Fixed frequency 2	20 Hz	0	1	0
2.051 to 2.057	Fixed frequency 3	30 Hz	0	1	1
2.051 to 2.057	Fixed frequency 4	35 Hz	1	0	0
2.051 to 2.057	Fixed frequency 5	40 Hz	1	0	1
2.051 to 2.057	Fixed frequency 6	45 Hz	1	1	0
2.051 to 2.057	Fixed frequency 7	50 Hz	1	1	1

Tab. 16: Logic table for fixed frequencies

1	2	3	4	5	6	7	8	9	10	11	12
---	---	---	---	---	---	---	---	---	----	----	----

5.2.2 Structure of the parameter tables

1	2	3	4	5
8	7	8	6	

1.100	Operating mode	Unit: integer	
Relationship to parameter: 1.131 1.130 2.051 to 2.057	Transfer status: 2	min: 0	Own value (to be entered!)
		max: 4	
		def.: 0	
Selection of operating mode, see page ... (reference to explanation in advance) Following successful software enabling (1.131) and hardware enabling, the drive controller runs as follows 0 = frequency setting mode, with the target value of the selected target value source (1.130), 1 = PID process controller, with the target value of the PID process controller, 2 = fixed frequencies, with the frequencies defined in parameters 2.051 – 2.057			

Fig. 36 Example of a parameter table

Key			
1	Parameter number	5	Unit
2	Parameter name	6	Field for entering an own value
3	Transfer status 0 = switch drive controller off and on for transfer 1 = at speed of 0 2 = during operation	7	Explanation of the parameter
4	Value range (from – to – factory setting)	8	Other parameters related to this parameter.

1	2	3	4	5	6	7	8	9	10	11	12
---	---	---	---	---	---	---	---	---	----	----	----

5.3 Application parameters

5.3.1 Basic parameter

1.020	Minimum frequency	Unit: Hz	
Relationship to parameter: 1.150 3.070 3.080 5.085	Transfer status: 2	min.: 0	Own value (to be entered!)
		max.: 400	
		def.: 0	
The minimum frequency is the frequency which is supplied by the drive controller as soon as it is enabled and there is no additional target value. The frequency falls below this level if: a) the drive accelerates from stationary b) the frequency converter is blocked. The frequency then falls to 0 Hz before it is blocked. c) the frequency converter reverses (1.150). The field of rotation reverses at 0 Hz. d) the standby function (3.070) is active. e) the current limit is reached			

1.021	Maximum frequency	Unit: Hz	
Relationship to parameter: 1.050 1.051	Transfer status: 2	min.: 0	Own value (to be entered!)
		max.: 400	
		def.: 50	
The maximum frequency is the highest frequency produced by the inverter depending on the target value.			

1.050	Deceleration time 1	Unit: s	
Relationship to parameter: 1.021 1.054	Transfer status: 2	min.: 0.1	Own value (to be entered!)
		max.: 1000	
		def.: 5	
Deceleration time 1 is the time that the drive controller needs to brake to 0 Hz from the max. frequency (1.021). If the set deceleration time cannot be reached, the fastest possible deceleration time is implemented.			

1.051	Run up time 1	Unit: s	
Relationship to parameter: 1.021 1.054	Transfer status: 2	min.: 0.1	Own value (to be entered!)
		max.: 1000	
		def.: 5	
Run up time 1 is the time that the drive controller needs to accelerate from 0 Hz to the max. frequency. The run up time can be increased as a result of certain circumstances, e.g. if the drive controller is overloaded.			

1.052	Deceleration time 2	Unit: s	
Relationship to parameter: 1.021 1.054	Transfer status: 2	min.: 0.1	Own value (to be entered!)
		max.: 1000	
		def.: 10	
Deceleration time 2 is the time that the drive controller needs to brake to 0 Hz from the max. frequency (1.021). If the set deceleration time cannot be reached, the fastest possible deceleration time is implemented.			

Parameter

1	2	3	4	5	6	7	8	9	10	11	12	
1.053												
Run up time 2												
Unit: s												
Relationship to parameter: 1.021 1.054	Transfer status: 2						min.: 0.1		Own value (to be entered!)			
							max.: 1000					
							def.: 10					
	Run up time 2 is the time that the drive controller needs to accelerate from 0 Hz to the max. frequency. The acceleration time can be increased as a result of certain circumstances, e.g. if the drive controller is overloaded.											

1.054												
Ramp selection												
Unit: integer												
Relationship to parameter: 1.050 - 1.053	Transfer status: 2						min.: 0		Own value (to be entered!)			
							max.: 9					
							def.: 0					
	Selection of used ramp pair 0 = deceleration time 1 (1.050) / run up time 1 (1.051) 1 = deceleration time 2 (1.052) / run up time 2 (1.053) 2 = digital input 1 (false = ramp pair 1 / true = ramp pair 2) 3 = digital input 2 (false = ramp pair 1 / true = ramp pair 2) 4 = digital input 3 (false = ramp pair 1 / true = ramp pair 2) 5 = digital input 4 (false = ramp pair 1 / true = ramp pair 2) 6 = customer PLC 7 = analogue input 1 (must be selected in parameter 4.030) (V 03.70 and higher) 8 = analogue input 2 (must be selected in parameter 4.060) (V 03.70 and higher) 9 = virtual output (4.230) (V 03.70 and higher)											

1.088												
Rapid stop												
Unit: s												
Relationship to parameter:	Transfer status: 2						min.: 0.1		Own value (to be entered!)			
							max.: 1000					
							def.: 10					
	Only for variant with functional safety The rapid stop parameter prescribes the time that the inverter requires to brake to 0 Hz from the max. speed (1.021). If the set rapid stop time cannot be achieved, the fastest possible deceleration time is implemented.											

1.100												
Operating mode												
Unit: integer												
Relationship to parameter: 1.130 1.131 2.051 to 2.057 3.050 to 3.071	Transfer status: 2						min.: 0		Own value (to be entered!)			
							max.: 3					
							def.: 0					
	Selecting the operating mode Following software enabling (1.131) and hardware enabling, the drive controller runs as follows: 0 = frequency setting mode, with the target value of the selected target value source (1.130) 1 = PID process controller, with the target value of the PID process controller (3.050 – 3.071), 2 = fixed frequencies, with the frequencies defined in parameters 2.051 – 2.057 3 = selection via FKO soft PLC											

Parameter

1	2	3	4	5	6	7	8	9	10	11	12
---	---	---	---	---	---	---	---	---	----	----	----

1.130	Target value source	Unit: integer	
Relationship to parameter: 3.062 to 3.069	Transfer status: 2	min.: 0	Own value (to be entered!)
		max.: 10	
		def.: 0	
Determines the source from which the target value is to be read. 0 = internal potentiometer 1 = analogue input 1 2 = analogue input 2 3 = MMI/PC 4 = SAS 6 = motor potentiometer 7 = sum of analogue inputs 1 and 2 8 = PID fixed target values (3.062 to 3.069) 9 = field bus 10 = FKO soft PLC			

1.131	Enable software	Unit: integer	
Relationship to parameter: 1.132 1.150 2.050 4.030 4.030 / 4.060	Transfer status: 2	min.: 0	Own value (to be entered!)
		max.: 16	
		def.: 0	
 DANGER! The motor may start immediately, depending on the change made. Selection of the source for the control release. 0 = digital input 1 1 = digital input 2 2 = digital input 3 3 = digital input 4 4 = analogue input 1 (must be selected in parameter 4.030) 5 = analogue input 2 (must be selected in parameter 4.060) 6 = field bus 7 = SAS / Modbus (V 03.080 and higher) 8 = digital input 1 on right / digital input 2 on left 1.150 must be set to "0" 9 = autostart The motor may start immediately if hardware is enabled and a target value has been provided. This cannot be prevented even with parameter 1.132. 10 = FKO soft PLC 11 = fixed frequency inputs (all inputs which were selected in parameter 2.050) 12 = internal potentiometer 13 = foil keypad (Start & Stop keys) 14 = MMI/PC 15 = virtual output (4.230) (V 03.70 and higher) 16 = foil keypad storing (V 03.70 and higher) 17 = edge of Dig In 1 start / Dig In 2 stop (V 03.92 and higher) 18 = edge for Dig In 1 start on right / edge for Dig In 2 start on left / Dig In 3 stop (V 03.92 and higher) 1.150 must be set to "0"			

Parameter

1	2	3	4	5	6	7	8	9	10	11	12
---	---	---	---	---	---	---	---	---	----	----	----

1.132	Start-up protection	Unit: integer	
Relationship to parameter: 1.131	Transfer status: 2	min.: 0	Own value (to be entered!)
		max.: 8	
		def.: 1	
Selection of behaviour in response to enabling software (parameter 1.131). No effect if autostart was selected. 0 = immediate start with high signal at input of control enable 1 = start only with rising edge at input of control enable 2 = digital input 1 (function active with high signal) 3 = digital input 2 (function active with high signal) 4 = digital input 3 (function active with high signal) 5 = digital input 4 (function active with high signal) 6 = FKO soft PLC 7 = analogue input 1 (must be selected in parameter 4.030) (V 03.70 and higher) 8 = analogue input 2 (must be selected in parameter 4.060) (V 03.70 and higher)			

1.150	Rotation direction	Unit: integer	
Relationship to parameter: 1.131 4.030 4.030 / 4.060	Transfer status: 2	min.: 0	Own value (to be entered!)
		max.: 16	
		def.: 0	
Selection of direction of rotation specification 0 = dependent on target value (depending on the plus or minus sign of the target value: positive: forwards; negative: backwards) 1 = forwards only (no change in direction of rotation possible) 2 = backwards only (no change in direction of rotation possible) 3 = digital input 1 (0 V = forwards, 24 V = backwards) 4 = digital input 2 (0 V = forwards, 24 V = backwards) 5 = digital input 3 (0 V = forwards, 24 V = backwards) 6 = digital input 4 (0 V = forwards, 24 V = backwards) 7 = FKO soft PLC 8 = analogue input 1 (must be selected in parameter 4.030) 9 = analogue input 2 (must be selected in parameter 4.060) 10 = foil keypad key for reversing direction of rotation (only when motor is running) 11 = foil keypad key I forwards / 2 backwards (reversal always possible) 12 = foil keypad key I forwards / 2 backwards (reversal only possible when motor stationary) 13 = virtual output (4.230) (V 03.70 and higher) 14 = foil keypad key for reversing direction of rotation (only in operational status) storing (V 03.70 and higher) 15 = foil keypad key I + II storing (V 03.70 and higher) 16 = foil keypad key I + II (only if motor is stationary) stores the last active rotation direction (V 03.70 and higher)			

1	2	3	4	5	6	7	8	9	10	11	12
---	---	---	---	---	---	---	---	---	----	----	----

1.180	Acknowledge function	Unit: integer	
Relationship to parameter: 1.181 1.182	Transfer status: 2	min.: 0	Own value (to be entered!)
		max.: 7	
		def.: 4	
Selection of the source for error confirmation. Errors can only be acknowledged once the error is no longer present. Auto acknowledgement via parameter 1.181. 0 = manual acknowledgement not possible 1 = rising flank at digital input 1 2 = rising flank at digital input 2 3 = rising flank at digital input 3 4 = rising flank at digital input 4 5 = foil keypad (Ackn key) 6 = analogue input 1 (must be selected in parameter 4.030) (V 03.70 and higher) 7 = analogue input 2 (must be selected in parameter 4.060) (V 03.70 and higher)			

1.181	Automatic acknowledgement function	Unit: s	
Relationship to parameter: 1.180 1.182	Transfer status: 2	min.: 0	Own value (to be entered!)
		max.: 1000	
		def.: 0	
In addition to the acknowledgement function (1.180), an automatic fault acknowledgement can be selected. 0 = no automatic acknowledgement > 0 = time for automatic resetting of error in seconds			

1.182	Number of automatic acknowledgements	Unit:	
Relationship to parameter: 1.180 1.181	Transfer status: 2	min.: 0	Own value (to be entered!)
		max.: 500	
		def.: 5	
In addition to the automatic acknowledgement function (1.181), it is possible to limit the maximum number of automatic acknowledgements here. 0 = no restriction on automatic acknowledgements > 0 = maximum number of automatic acknowledgements			



INFORMATION

INFORMATION

The internal counter for automatic acknowledgements already undertaken is reset if the motor is operated for the "maximum number of acknowledgements x auto acknowledgement time" period without any errors occurring (motor current > 0.2 A).

Example of resetting the auto acknowledgement counter

max. number of acknowledgements = 8
 auto acknowledgement time = 20 sec. } 8 x 20 sec. = 160 sec.

After 160 sec. of motor operation without errors, the internal counter for "auto acknowledgements" undertaken is reset to "0".

In this example, 8 "auto acknowledgements" were accepted.

If an error occurs within the 160 sec., "error 22" is triggered on the 9th acknowledgement attempt.

This error has to be acknowledged manually by switching off the mains.

1	2	3	4	5	6	7	8	9	10	11	12
---	---	---	---	---	---	---	---	---	----	----	----

5.3.2 Fixed frequency

This mode has to be selected in parameter 1.100, see also the section on selecting the operating mode.

2.050	Fixed frequency mode	Unit: integer	
Relationship to parameter: 1.100 2.051 to 2.057	Transfer status: 2	min.: 0	Own value (to be entered!)
		max.: 4	
		def.: 2	
Selection of the digital inputs used for fixed frequencies 0 = Digital In 1 (Fixed frequency 1) (2.051) 1 = Digital In 1, 2 (Fixed frequencies 1 - 3) (2.051 to 2.053) 2 = Digital In 1, 2, 3 (Fixed frequencies 1 - 7) (2.051 to 2.057) 3 = foil keypad (key I = fixed frequency 1 / key II = fixed frequency 2) 4 = fixed frequency (key I = fixed frequency 1 / key II = fixed frequency 2) storing (V 03.70 and higher)			

2.051 to 2.057	Fixed frequency	Unit: Hz	
Relationship to parameter: 1.020 1.021 1.100 1.150 2.050	Transfer status: 2	min.: - 400	Own value (to be entered!)
		max.: + 400	
		def.: 0	
The frequencies that are to be output at the digital inputs 1 - 3 specified in parameter 2.050 depending on the switching patterns. See chapter 5.2.1 Explanation of operating modes / fixed frequency.			

5.3.3 Motor potentiometer

This mode must be selected in parameter 1.130.

The function can be used as a target value source for frequency mode and for the PID process controller.

The motor potentiometer can be used to gradually increase / decrease the target value (PID/frequency). Use parameters 2.150 to 2.154 for this purpose.

2.150	MOP digital Input	Unit: integer	
Relationship to parameter: 1.130 4.030 4.050	Transfer status: 2	min.: 0	Own value (to be entered!)
		max.: 8	
		def.: 3	
Selection of the source for increasing and reducing the target value 0 = digital input 1 + / digital input 2 - 1 = digital input 1 + / digital input 3 - 2 = digital input 1 + / digital input 4 - 3 = digital input 2 + / digital input 3 - 4 = digital input 2 + / digital input 4 - 5 = digital input 3 + / digital input 4 - 6 = analogue input 1 + / analogue input 2 - (must be selected in parameters 4.030 / 4.050) 7 = FKO soft PLC 8 = foil keypad (key 1 - / key 2 +)			

Parameter

1	2	3	4	5	6	7	8	9	10	11	12	
	2.151	MOP step range					Unit: %					
	Relationship to parameter: 1.020 1.021	Transfer status: 2					min.:	0	Own value (to be entered!)			
							max.:	100				
							def.:	1				
Increments at which the target value changes per keystroke.												

	2.152	MOP step time					Unit: s					
	Relationship to parameter:	Transfer status: 2					min.:	0.02	Own value (to be entered!)			
							max.:	1000				
							def.:	0.04				
Indicates the time during which the target value is totalled with a permanent signal.												

	2.153	MOP response time					Unit: s					
	Relationship to parameter:	Transfer status: 2					min.:	0.02	Own value (to be entered!)			
							max.:	1000				
							def.:	0.3				
Indicates the time for which the signal is considered permanent.												

	2.154	MOP reference memory					Unit: integer					
	Relationship to parameter:	Transfer status: 2					min.:	0	Own value (to be entered!)			
							max.:	1				
							def.:	0				
Defines whether the target value of the motor potentiometer is retained even after power outage. 0 = disable 1 = enable												

5.3.4 PID process controller

This mode must be selected in parameter 1.100, the target value source must be selected in parameter 1.130, see also chapter 5.2.1 Explanation of operating modes / fixed frequency.

	3.050	PID-P amplification factor					Unit:					
	Relationship to parameter: 1.100 1.130	Transfer status: 2					min.:	0	Own value (to be entered!)			
							max.:	100				
							def.:	1				
Proportional share of PID controller amplification factor												

	3.051	PID-I amplification factor					Unit: 1/s					
	Relationship to parameter: 1.100 1.130	Transfer status: 2					min.:	0	Own value (to be entered!)			
							max.:	100				
							def.:	1				
Integral share of PID controller amplification factor												

Parameter

1	2	3	4	5	6	7	8	9	10	11	12
---	---	---	---	---	---	---	---	---	----	----	----

3.052	PID-D amplification factor	Unit: s	
Relationship to parameter: 1.100 1.130	Transfer status: 2 Differential share of PID controller amplification factor	min.: 0	Own value (to be entered!)
		max.: 100	
		def.: 0	

3.055	PID mode	Unit: integer	
Relationship to parameter: 1.100 1.130	Transfer status: 2 (V 03.84 and higher) Switches can be made between PID modes here: 0: Standard (no consideration of actual frequency) 1: with consideration of actual frequency	min.: 0	Own value (to be entered!)
		max.: 1	
		def.: 0	

3.060	PID actual value	Unit: integer	
Relationship to parameter: 1.100 1.130 3.061	Transfer status: 2 Selection of the input source from which the actual value for the PID process controller is imported: 0 = analogue input 1 1 = analogue input 2 2 = FKO soft PLC 3 = field bus (fixed customer-specific input variable 2) (V 03.72 and higher)	min.: 0	Own value (to be entered!)
		max.: 3	
		def.: 0	

3.061	PID inverted	Unit: integer	
Relationship to parameter: 3.060	Transfer status: 2 The actual value source (parameter 3.060) is inverted 0 = disable 1 = enable	min.: 0	Own value (to be entered!)
		max.: 1	
		def.: 0	

3.062 to 3.068	PID fixed target values	Unit: %	
Relationship to parameter: 1.130 3.069	Transfer status: 2 The PID fixed target values which are to be issued depending on the switching patterns at the digital inputs 1 – 3 specified in parameter 3.069 (has to be selected in parameter 1.130).	min.: 0	Own value (to be entered!)
		max.: 100	
		def.: 0	

Parameter

1	2	3	4	5	6	7	8	9	10	11	12
---	---	---	---	---	---	---	---	---	----	----	----

3.069	PID fixed target mode	Unit: integer	
Relationship to parameter: 1.100 3.062 to 3.068	Transfer status: 2	min.: 0	Own value (to be entered!)
		max.: 2	
		def.: 0	
Selection of the digital inputs used for fixed frequencies			
0 = Digital In 1 (PID fixed target value 1) (3.064)			
1 = Digital In 1, 2 (PID fixed target values 1 – 3) (3.062 to 3.064)			
2 = Digital In 1, 2, 3 (PID fixed target values 1 – 7) (3.062 to 3.068)			

3.070	PID standby time	Unit: s	
Relationship to parameter: 1.020	Transfer status: 2	min.: 0	Own value (to be entered!)
		max.: 10000	
		def.: 0	
If the drive controller runs for the set time at its minimum frequency (parameter 1.020), the motor is stopped (0 Hz), see also Chapter 5.2.1 Explanation of operating modes / fixed frequency.			
0 = disable			
> 0 = waiting time until stand-by function is enabled			

3.071	PID stand-by hysteresis	Unit: %	
Relationship to parameter: 3.060	Transfer status: 2	min.: 0	Own value (to be entered!)
		max.: 50	
		def.: 0	
Condition for waking up the PID controller from stand-by.			
Once the control difference exceeds the set value as %, the control begins again, see also PID controller operating modes.			

3.072	PID dry run time	Unit: s	
Relationship to parameter:	Transfer status: 2	min.: 0	Own value (to be entered!)
		max.: 32767	
		def.: 0	
(V 03.70 and higher)			
After this set time, if the PID actual value has not reached at least 5 % and the controller is running at the max. limit, the FKO switches off with error no. 16 PID dry run.			

3.073	PID nominal value min	Unit: %	
Relationship to parameter: 3.074	Transfer status: 2	min.: 0	Own value (to be entered!)
		max.: 100	
		def.: 0	
(V 03.70 and higher)			
The PID nominal value can be limited using 2 parameters.			
Example: 0 -10 V nominal value potentiometer			
Read Min PID nominal value = 20 %			
Read Max PID nominal value = 80 % (3.074)			
Nominal value at < 2 V = 20 %			
Nominal value at 2 V – 8 V = 20 % - 80 %			
Nominal value at > 8 V = 80 %			

Parameter

1	2	3	4	5	6	7	8	9	10	11	12
3.074		PID nominal value max					Unit: %				
Relationship to parameter: 3.073	Transfer status: 2					min.:	0	Own value (to be entered!)			
						max.:	100				
						def.:	100				
(V 03.70 and higher) The PID nominal value can be limited using 2 parameters. Example: 0 -10 V nominal value potentiometer Read Min PID nominal value = 20 % Read Max PID nominal value = 80 % (3.073) Nominal value at < 2 V = 20 % Nominal value at 2 V – 8 V = 20 % - 80 % Nominal value at > 8 V = 80 %											

3.080		PID minimum frequency 2					Unit: Hz				
Relationship to parameter: 1.020	Transfer status: 2					min.:	0	Own value (to be entered!)			
						max.:	400				
						def.:	0				
(V 03.80 and higher) The minimum frequency is calculated depending on the PID target value Example: 1.020 minimum frequency = 10 Hz 3.080 PID minimum frequency 2 = 20 Hz Minimum frequency when PID target value is 0 % = 10 Hz Minimum frequency when PID target value is 50 % = 15 Hz Minimum frequency when PID target value is 100 % = 20 Hz											

5.3.5 Analogue inputs

For analogue inputs 1 and 2 (AIx display AI1/AI2)

4.020 / 4.050		Aix input type					Unit: integer				
Relationship to parameter:	Transfer status: 2					min.:	1	Own value (to be entered!)			
						max.:	2				
						def.:	1				
Function of analogue inputs 1 / 2. 1 = voltage input 2 = current input											

Parameter

1	2	3	4	5	6	7	8	9	10	11	12	
4.021 / 4.051	Relationship to parameter:	Aix standard Low					Unit: %					
		Transfer status: 2					min.: 0		max.: 100		def.: 0	
Specifies the minimum value of the analogue inputs as a percentage of the range Example: 0...10 V and/or 0...20 mA = 0 %...100 % 2...10 V or 4...20 mA = 20 %...100 %												
4.022 / 4.052	Relationship to parameter:	Aix standard High					Unit: %					
		Transfer status: 2					min.: 0		max.: 100		def.: 100	
Specifies the maximum value of the analogue inputs as a percentage of the range. Example: 0...10 V and/or 0...20 mA = 0 %...100 % 2...10 V or 4...20 mA = 20 %...100 %												
4.023 / 4.053	Relationship to parameter:	Aix dead time					Unit: %					
		Transfer status: 2					min.: 0		max.: 100		def.: 0	
Dead time as percentage of the range of the analogue inputs.												
4.024 / 4.054	Relationship to parameter:	Aix filter time					Unit: s					
		Transfer status: 2					min.: 0.02		max.: 1.00		def.: 0	
Filter time of analogue inputs in seconds.												
4.030 / 4.060	Relationship to parameter:	Aix function					Unit: integer					
		Transfer status: 2					min.: 0		max.: 1		def.: 0	
Function of analogue inputs 1/2 0 = analogue input 1 = digital input												

Parameter

1	2	3	4	5	6	7	8	9	10	11	12
---	---	---	---	---	---	---	---	---	----	----	----

4.033 / 4.063	Aix physical unit	Unit:	
Relationship to parameter: 4.034 / 4.064 4.035 / 4.065	Transfer status: 2	min.: 0	Own value (to be entered!)
		max.: 10	
		def.: 0	
		Selection of different physical values to be displayed. <ul style="list-style-type: none"> 0 = % 1 = bar 2 = mbar 3 = psi 4 = Pa 5 = m³/h 6 = l/min 7 = °C 8 = °F 9 = m 10 = mm 	

4.034 / 4.064	Aix physical minimum	Unit:	
Relationship to parameter: 4.033 / 4.063 4.035 / 4.065	Transfer status: 2	min.: - 10000	Own value (to be entered!)
		max.: + 10000	
		def.: 0	
		Selection of the lower limit of a physical value to be displayed.	

4.035 / 4.065	Aix physical maximum	Unit:	
Relationship to parameter: 4.033 / 4.063 4.034 / 4.064	Transfer status: 2	min.: - 10000	Own value (to be entered!)
		max.: + 10000	
		def.: 100	
		Selection of the upper limit of a physical value to be displayed.	

4.036 / 4.066	Aix wire break time	Unit:	
Relationship to parameter:	Transfer status: 2	min.: 0	Own value (to be entered!)
		max.: 32767	
		def.: 0.5	
		(V 03.70 and higher) Once the mains is activated, wire break detection is only activated after this set time	

4.037 / 4.067	Aix inverted	Unit: integer	
Relationship to parameter:	Transfer status: 2	min.: 0	Own value (to be entered!)
		max.: 1	
		def.: 0	
		(V 03.80 and higher) The signal of the analogue input can be inverted here. 0 = disable (example: 0 V = 0 % 10 V = 100 %) 1 = enable (example: 0 V = 100 % 10 V = 0 %)	

1	2	3	4	5	6	7	8	9	10	11	12
---	---	---	---	---	---	---	---	---	----	----	----

5.3.6 Digital inputs

4.110 to 4.113	Dlx inverted	Unit: integer	
Relationship to parameter:	Transfer status: 2	min.: 0	Own value (to be entered!)
		max.: 1	
		def.: 0	
This parameter can be used to invert the digital input. 0 = disable 1 = enable			

5.3.7 Analogue output

4.100	AO1 function	Unit: integer	
Relationship to parameter: 4.101 4.102	Transfer status: 2	min.: 0	Own value (to be entered!)
		max.: 40	
		def.: 0	
Selection of the process value that is output at the analogue output. Depending on the process value selected, the standardisation (4.101 / 4.102) must be adapted.			
<ul style="list-style-type: none"> 0 = Not assigned / FKO soft PLC 1 = Intermediate circuit voltage 2 = Grid voltage 3 = Motor voltage 4 = Motor current 5 = Actual frequency 6 = Speed measured externally by speed sensor (if available) 7 = Current angle or position (if available) 8 = IGBT temperature 9 = Inner temperature 10 = Analogue input 1 11 = Analogue input 2 12 = Target frequency 13 = Motor rating 14 = Torque 15 = Field bus 16 = PID target value (V 03.60 and higher) 17 = PID actual value (V 03.60 and higher) 18 = Target frequency value after ramp (V 03.74 and higher) 19 = Actual speed value (V 03.74 and higher) 20 = Actual frequency value sum (V 03.74 and higher) 21 = Torque sum (V 03.74 and higher) 22 = Target frequency value after ramp sum (V 03.74 and higher) 23 = Target frequency value sum (V 03.74 and higher) 24 = Actual speed value sum (V 03.74 and higher) 			

4.101	AO1 standard Low	Unit:	
Relationship to parameter: 4.100	Transfer status: 2	min.: - 10000	Own value (to be entered!)
		max.:+ 10000	
		def.: 0	
Describes which area is to be broken down into the 0-10 V output voltage or the 0-20 mA output current.			

Parameter

1	2	3	4	5	6	7	8	9	10	11	12	
4.102		AO1 standard High						Unit:				
Relationship to parameter:		Transfer status: 2						min.: - 10000		Own value (to be entered!)		
4.100								max.:+ 10000				
								def.: 0				
Describes which area is to be broken down into the 0-10 V output voltage or the 0-20 mA output current.												

5.3.8 Digital outputs

For digital outputs 1 and 2 (Dox display DO1 / DO2)

4.150 / 4.170	Dox function	Unit: integer	
Relationship to parameter:	Transfer status: 2	min.: 0	Own value (to be entered!)
4.151 / 4.171		max.: 51	
4.152 / 4.172		def.: 0	
<p>Selection of the process variable to which the output should switch.</p> <ul style="list-style-type: none"> 0 = Not assigned / FKO soft PLC 1 = Intermediate circuit voltage 2 = Grid voltage 3 = Motor voltage 4 = Motor current 5 = Actual frequency value 6 = - 7 = - 8 = IGBT temperature 9 = Inner temperature 10 = Error (NO) 11 = Error inverted (NC) 12 = Limit steps enable 13 = Digital input 1 14 = Digital input 2 15 = Digital input 3 16 = Digital input 4 17 = Ready for operation (mains supply on, no HW enable, motor stationary) 18 = Ready (mains supply on, HW enable set, motor stationary) 19 = Operation (mains supply on, HW enable set, motor running) 20 = Ready for operation + Ready 21 = Ready for operation + Ready + Operation 22 = Ready + Operation 23 = Motor rating 24 = Torque 25 = Field bus 26 = Analogue input 1 (V 03.60 and higher) 27 = Analogue input 2 (V 03.60 and higher) 28 = PID target value (V 03.60 and higher) 29 = PID actual value (V 03.60 and higher) 30 = STO channel 1 (V 03.70 and higher) 31 = STO channel 2 (V 03.70 and higher) 32 = Target frequency value after ramp (V 03.70 and higher) 33 = Target frequency value (V 03.70 and higher) 34 = Actual speed value (V 03.70 and higher) 35 = Actual frequency value sum (V 03.70 and higher) 36 = Torque sum (V 03.70 and higher) 37 = Target frequency value after ramp sum (V 03.70 and higher) 38 = Target frequency value sum (V 03.70 and higher) 39 = Actual speed value sum (V 03.70 and higher) 40 = Virtual output (V03.92 and higher) 40 = Motor current limit enabled (V 03.70 and higher) 51 = Nominal-actual comparison (para. 6.070 – 6.071) (V 03.70 and higher) 			

Parameter

1	2	3	4	5	6	7	8	9	10	11	12	
4.151 / 4.171		Dox on						Unit:				
Relationship to parameter:	4.150 / 4.170	Transfer status: 2						min.: - 32767		Own value (to be entered!)		
								max.: 32767				
								def.: 0				
If the set process variable exceeds the switch-on limit, the output is set to 1.												

4.152 / 4.172		Dox off						Unit:				
Relationship to parameter:	4.150 / 4.170	Transfer status: 2						min.: - 32767		Own value (to be entered!)		
								max.: 32767				
								def.: 0				
If the set process variable exceeds the switch-off limit, the output is again set to 0.												

5.3.9 Relay

For relays 1 and 2 (rel. X – display rel. 1/ rel. 2)

4.190 / 4.210		Rel.x function						Unit: integer				
Relationship to parameter:	4.191 / 4.211 4.192 / 4.212	Transfer status: 2						min.: 0		Own value (to be entered!)		
								max.: 51				
								def.: 0				
<p>Selection of the process variable to which the output should switch.</p> <ul style="list-style-type: none"> 0 = Not assigned / FKO soft PLC 1 = Intermediate circuit voltage 2 = Grid voltage 3 = Motor voltage 4 = Motor current 5 = Actual frequency value 6 = - 7 = - 8 = IGBT temperature 9 = Inner temperature 10 = Error (NO) 11 = Error inverted (NC) 12 = Limit steps enable 13 = Digital input 1 14 = Digital input 2 15 = Digital input 3 16 = Digital input 4 17 = Ready for operation (mains supply on, no HW enable, motor stationary) 18 = Ready (mains supply on, HW enable set, motor stationary) 19 = Operation (mains supply on, HW enable set, motor running) 20 = Ready for operation + Ready 21 = Ready for operation + Ready + Operation 22 = Ready + Operation 23 = Motor rating 24 = Torque 25 = Field bus <p style="text-align: right;">Table continues on next page</p>												

Parameter

1	2	3	4	5	6	7	8	9	10	11	12
---	---	---	---	---	---	---	---	---	----	----	----

4.190 / 4.210	Rel.x function	Unit: integer	
Relationship to parameter: 4.191 / 4.211 4.192 / 4.212	Transfer status: 2	min.: 0	Own value (to be entered!)
		max.: 51	
		def.: 0	
Selection of the process variable to which the output should switch. Continuation of table			
26 = Analogue input 1 (V 03.60 and higher) 27 = Analogue input 2 (V 03.60 and higher) 28 = PID target value (V 03.60 and higher) 29 = PID actual value (V 03.60 and higher) 30 = STO channel 1 (V 03.70 and higher) 31 = STO channel 2 (V 03.70 and higher) 32 = Target frequency value after ramp (V 03.70 and higher) 33 = Target frequency value (V 03.70 and higher) 34 = Actual speed value (V 03.70 and higher) 35 = Actual frequency value sum (V 03.70 and higher) 36 = Torque sum (V 03.70 and higher) 37 = Target frequency value after ramp sum (V 03.70 and higher) 38 = Target frequency value sum (V 03.70 and higher) 39 = Actual speed value sum (V 03.70 and higher) 40 = Virtual output (V03.92 and higher) 50 = Motor current limit enabled (V 03.70 and higher) 51 = Nominal-actual comparison (para. 6.070 – 6.071) (V 03.70 and higher)			

4.191 / 4.211	Rel.x on	Unit:	
Relationship to parameter: 4.190 / 4.210	Transfer status: 2	min.: - 32767	Own value (to be entered!)
		max.: 32767	
		def.: 0	
If the set process variable exceeds the switch-on limit, the output is set to 1.			

4.192 / 4.212	Rel.x off	Unit:	
Relationship to parameter: 4.190 / 4.210	Transfer status: 2	min.: - 32767	Own value (to be entered!)
		max.: 32767	
		def.: 0	
If the set process variable exceeds the switch-off limit, the output is again set to 0.			

4.193/ 4.213	Rel.x on delay	Unit: s	
Relationship to parameter: 4.194 / 4.214	Transfer status: 2	min.: 0	Own value (to be entered!)
		max.: 10000	
		def.: 0	
Specifies the length of the switch-on delay.			

4.194/ 4.214	Rel.x off delay	Unit:	
Relationship to parameter: 4.193 / 4.213	Transfer status: 2	min.: 0	Own value (to be entered!)
		max.: 10000	
		def.: 0	
Specifies the length of the switch-off delay.			

1	2	3	4	5	6	7	8	9	10	11	12
---	---	---	---	---	---	---	---	---	----	----	----

5.3.10 Virtual output

The virtual output can be parameterised like a relay and is available as an option with the following parameters:

1.131 Software enable / 1.150 Direction of rotation / 1.054 Ramp selection /
5.090 Parameter set change / 5.010 + 5.011 External error 1 + 2

4.230	VO function	Unit: integer	
Relationship to parameter: 1.054 1.131 1.150 4.231 4.232 5.010 / 5.011 5.010 / 5.011 5.090	Transfer status: 2	min.: 0	Own value (to be entered!)
		max.: 51	
		def.: 0	
	(V 03.70 and higher) Selection of the process variable to which the output should switch.		
	0 = Not assigned / FKO soft PLC 1 = Intermediate circuit voltage 2 = Grid voltage 3 = Motor voltage 4 = Motor current 5 = Actual frequency value 6 = - 7 = - 8 = IGBT temperature 9 = Inner temperature 10 = Error (NO) 11 = Error inverted (NC) 12 = Limit steps enable 13 = Digital input 1 14 = Digital input 2 15 = Digital input 3 16 = Digital input 4 17 = Ready for operation (mains supply on, no HW enable, motor stationary) 18 = Ready (mains supply on, HW enable set, motor stationary) 19 = Operation (mains supply on, HW enable set, motor running) 20 = Ready for operation + Ready 21 = Ready for operation + Ready + Operation 22 = Ready + Operation 23 = Motor rating 24 = Torque 25 = Fieldbus (V 03.84 and higher) 26 = Analogue input 1 27 = Analogue input 2 28 = PID target value 29 = PID actual value 30 = STO channel 1 31 = STO channel 2 32 = Nominal frequency value after ramp 33 = Target frequency value 34 = Actual speed value 35 = Actual frequency value sum 36 = Torque sum 37 = Nominal frequency value after ramp sum 38 = Target frequency value sum 39 = Actual speed value sum 50 = Motor current limit enabled 51 = Nominal-actual comparison (para. 6.070 – 6.071)		

4.231	VO-On	Unit:	
Relationship to parameter: 4.230	Transfer status: 2	min.: - 32767	Own value (to be entered!)
		max.: 32767	
		def.: 0	
If the set process variable exceeds the switch-on limit, the output is set to 1.			

Parameter

1	2	3	4	5	6	7	8	9	10	11	12
---	---	---	---	---	---	---	---	---	----	----	----

4.232	VO-Off	Unit:	
Relationship to parameter: 4.230	Transfer status: 2	min.: - 32767	Own value (to be entered!)
		max.: 32767	
		def.: 0	
If the set process variable exceeds the switch-off limit, the output is again set to 0.			

4.233	VO-On delay	Unit: s	
Relationship to parameter: 4.234	Transfer status: 2	min.: 0	Own value (to be entered!)
		max.: 10000	
		def.: 0	
Specifies the length of the switch-on delay.			

4.234	VO-Off delay	Unit:	
Relationship to parameter: 4.233	Transfer status: 2	min.: 0	Own value (to be entered!)
		max.: 10000	
		def.: 0	
Specifies the length of the switch-off delay.			

4,235	VO inverted	Unit: integer	
Relationship to parameter: 4.230	Transfer status: 2	min.: 0	Own value (to be entered!)
		max.: 1	
		def.: 0	
(V03.92 and higher) This parameter can be used to invert the virtual output. 0 = disable 1 = enable			

5.3.11 External fault

5.010 / 5.011	External fault 1/2	Unit: integer	
Relationship to parameter: 4.110 / 4.113 4.230	Transfer status: 2	min.: 0	Own value (to be entered!)
		max.: 7	
		def.: 0	
<p>Selection of source via which an external fault can be reported.</p> <ul style="list-style-type: none"> 0 = Not assigned / FKO soft PLC 1 = Digital input 1 2 = Digital input 2 3 = Digital input 3 4 = Digital input 4 5 = Virtual output (parameter 4.230) (V 03.70 and higher) 6 = Analogue input 1 (must be selected in parameter 4.030) (V 03.70 and higher) 7 = Analogue input 2 (must be selected in parameter 4.060) (V 03.70 and higher) <p>If there is a high signal at the selected digital input, the drive controller with error no. 23 / 24, switches external error ½.</p> <p>Parameters 4.110 to 4.113 Dix inverse can be used to invert the logic of the digital input.</p>			

1	2	3	4	5	6	7	8	9	10	11	12
---	---	---	---	---	---	---	---	---	----	----	----

5.3.12 Motor current limit

This function limits the motor current to a parameterised maximum value after a parameterised current-time zone has been reached.

This motor current limit is monitored at application level and thereby limits with relatively low dynamics. This has to be taken into consideration when selecting this function.

The maximum value is determined using the “motor current limit as %” parameter (5.070).

This is stated as a percentage and relates to the nominal motor current specified in the “motor current” type plate data (33.031).

The maximum current-time zone is calculated from the product of the “motor current limit in s” parameter (5.071) and the fixed overcurrent of 50% of the required motor current limit.

As soon as this current-time zone is exceeded, the motor current is restricted to the limit value by reducing the speed. If the output current of the drive controller exceeds the motor current (parameter 33.031) multiplied by the set limit as % (parameter 5.070) for the set time (parameter 5.071), the output current of the drive controller is limited permanently to the parametrised value.

The entire function can be deactivated by setting the “motor current limit as %” parameter (5.070) to zero.

5.070	Motor current limit as %	Unit: %	
Relationship to parameter: 5.071 33.031	Transfer status: 2	min.: 0	Own value (to be entered!)
		max.: 250	
		def.: 0	
0 = disable See description 5.3.1			

5.071	Motor current limit S	Unit: s	
Relationship to parameter: 5.070 33.031	Transfer status: 2	min.: 0	Own value (to be entered!)
		max.: 100	
		def.: 1	
See description 5.3.1			

5.075	Gearbox factor	Unit:	
Relationship to parameter: 33.034	Transfer status: 2	min.: 0	Own value (to be entered!)
		max.: 1000	
		def.: 1	
A gearbox factor can be set here. The mechanical speed display can be adjusted using the gearbox factor.			

5.3.13 Stall detection

5.080	Blocking detection	Unit: integer	
Relationship to parameter: 5.081 34.110	Transfer status: 2	min.: 0	Own value (to be entered!)
		max.: 1	
		def.: 0	
This parameter can be used to activate stall detection. 0 = disable 1 = enable This function only works reliably if the motor data has been entered correctly and the slip compensation has not been deactivated.			

Parameter

1	2	3	4	5	6	7	8	9	10	11	12
5.081	Blocking time					Unit: s					
Relationship to parameter:	Transfer status: 2					min.:	0	Own value (to be entered!)			
5.080						max.:	50				
						def.:	2				
Indicates the time after which a blockage is detected.											

5.3.14 Additional function

5.082	Start-up error active					Unit: integer					
Relationship to parameter:	Transfer status: 2					min.:	0	Own value (to be entered!)			
4.233						max.:	1				
						def.:	1				
<p>(V 03.70 and higher)</p> <p>Start-up error is defined as follows: Actual value does not reach 10 % of the rated motor frequency after 30 seconds (if target frequency < 10 %, the error is not generated). If the acceleration time is parametrised as > 60 seconds, half the acceleration time is used in place of the 30 seconds.</p> <p>0 = Function disabled 1 = Function enabled</p>											

5.083	Deactivation error log 11					Unit: integer					
Relationship to parameter:	Transfer status: 2					min.:	0	Own value (to be entered!)			
						max.:	10				
						def.:	0				
<p>(V 03.94 and higher)</p> <p>If supplied with external 24 V, the logging of error no. 11 "Time out power" can be suppressed here. The error counter is not affected.</p> <p>0 = Function disabled 1 = Function enabled (Error number 11 is not logged) 2 = Function enabled (Error no.11 issued as a warning)</p>											

5.085	F. min monitoring					Unit: s					
Relationship to parameter:	Transfer status: 2					min.:	0	Own value (to be entered!)			
1.020						max.:	10000				
						def.:	0				
<p>(V 03.92 and higher)</p> <p>The delay for monitoring the minimum frequency can be set here. If the minimum frequency for the set time is not reached, error 28 is generated.</p> <p>0s = function disabled >0s = function enabled</p> <p>The time must be long enough for the motor to be able to reliably start.</p>											

5.086	F. max monitoring					Unit: s					
Relationship to parameter:	Transfer status: 2					min.:	0	Own value (to be entered!)			
1.021						max.:	10000				
						def.:	0				
<p>(V 03.92 and higher)</p> <p>The delay for monitoring the maximum frequency can be set here. If the maximum frequency for the set time is exceeded, error 28 is generated.</p> <p>0s = function disabled >0s = function enabled</p>											

Parameter

1	2	3	4	5	6	7	8	9	10	11	12	
5.090												
Parameter set change												
Unit: integer												
Relationship to parameter:	Transfer status: 2										min.: 0	Own value (to be entered!)
											max.: 12	
											def.: 0	
<p>Selection of the active data set.</p> <ul style="list-style-type: none"> 0 = Not used 1 = Data set 1 active 2 = Data set 2 active 3 = Digital input 1 4 = Digital input 2 5 = Digital input 3 6 = Digital input 4 7 = FKO soft PLC 8 = Virtual output (parameter 4.230) (V 03.70 and higher) 9 = Analogue input 1 (must be selected in parameter 4.030) (V 03.70 and higher) 10 = Analogue input 2 (must be selected in parameter 4.060) (V 03.70 and higher) 11 = Foil keypad key I for data set 1, key II for data set 2 (V 03.70 and higher) 12 = Foil keypad key I for data set 1, key II for data set 2 storing (V 03.70 and higher) <p>The 2nd data set is only displayed in the PC software if this parameter is <= 0. The values of the data set currently selected are always displayed in the MMI.</p>												
<p>4.030 / 4.060 4.230</p>												

5.3.15 HMI Parameters

5.200												
Turning MMI* display												
Unit: integer												
Relationship to parameter:	Transfer status: 2										min.: 0	Own value (to be entered!)
											max.: 1	
											def.: 0	
<p>(V 03.80 and higher)</p> <p>Only for MMI in cover. Here the user can define whether the screen / key assignment is turned 180°.</p> <p>0 = Function disabled 1 = Function enabled</p>												

5.201												
Save MMI* display												
Unit: integer												
Relationship to parameter:	Transfer status: 2										min.: 1	Own value (to be entered!)
											max.: 5	
											def.: 1	
<p>(V 03.80 and higher)</p> <p>The status screen displayed in the MMI * can be selected here.</p> <ul style="list-style-type: none"> 1 = status 01: Target / actual frequency / motor current 2 = status 02: Speed / motor current / process value 1 3 = status 03: Speed / motor current / process value 2 4 = status 04: Speed / PID target value / PID actual value 5 = status 05: Customer PLC output variable 1 / 2 / 3 												

* Man-machine interface

1	2	3	4	5	6	7	8	9	10	11	12
---	---	---	---	---	---	---	---	---	----	----	----

5.202	MMI* password	Unit: integer	
Relationship to parameter:	Transfer status: 2	min.: 0	Own value (to be entered!)
		max.: 9999	
		def.: 0	
(V 03.88 and higher) A password can be allocated here, which is requested when expert mode is selected in the MMI *. 0: Password request deactivated The password can be individually set in both data sets.			

5.210	MMI* option language	Unit: integer	
Relationship to parameter:	Transfer status: 2	min.: 0	Own value (to be entered!)
		max.: 1	
		def.: 0	
(V 03.88 and higher) This parameter can be used to select the language which the MMI * option displays. 0 = local language (factory setting is German) 1 = English This setting does not affect the language choice for the MMI handheld controller.			

5.3.16 Fieldbus

6.010	Ethernet fieldbus	Unit: integer	
Relationship to parameter:	Transfer status: 0	min.: 0	Own value (to be entered!)
		max.: 1	
		def.: 0	
ONLY FOR DEVICE VARIANTS WITH ETHERNET FIELDBUS MODULES (e.g. AP17 / AP26 / AP47 / AP56) This parameter can be used to select the Ethernet fieldbus cycle: 0 = Profinet 1 = Sercos III			
<div style="border: 1px solid black; padding: 5px;">  <p>IMPORTANT INFORMATION</p> <p>May result in destruction of the device. The FKO must be de-energised once after the parameter has been changed! Once the voltage is activated, the selected fieldbus cycle is loaded, this process may take one to two minutes. The FKO must not be switched off during this time! Once successfully loaded, the FKO restarts!</p> </div>			

Parameter

1	2	3	4	5	6	7	8	9	10	11	12
---	---	---	---	---	---	---	---	---	----	----	----

6.060	Fieldbus address	Unit: integer	
Relationship to parameter:	Transfer status: 0	min.: 0	Own value (to be entered!)
		max.: 127	
		def.: 0	
	<p>For this address to be used, the address coding switches in the device must be set to 00. A change to the fieldbus address is only undertaken once FKO is restarted (V 03.80 and higher) Profibus devices are automatically set to the "Default 125" address with address coding setting "00" and parameter "0".</p>		

6.061	Field bus baud rate	Unit: integer	
Relationship to parameter:	Transfer status: 2	min.: 1 0	Own value (to be entered!)
		max.: 8	
		def.: 2	
	<p>Only for CanOpen: 0 = 1 Mbit, 2 = 500 kBit, 3 = 250 kBit, 4 = 125 kBit, 6 = 50 kBit, 7 = 20 kBit, 8 = 10 kBit</p>		

* Man-machine interface

Parameter

1	2	3	4	5	6	7	8	9	10	11	12	
6.062		Bus time-out						Unit in s				
Relationship to parameter:		Transfer status: 2						min.: 0	Own value (to be entered!)			
								max.: 100				
								def.: 5				
Bus timeout, if no fieldbus telegram is received after the set time has expired, the FKO shuts down with the "Bus timeout" error. The function is only activated once a telegram has been successfully received. 0 = Monitoring disabled												



IMPORTANT INFORMATION

Changing a parameter value via the fieldbus includes direct EEPROM write access.

6.070 / 6.071	Target / nominal value deviation	Unit: %	
Relationship to parameter: 4.150 / 4.170 4.190 / 4.210 4.230	Transfer status: 2	min.: 0 % / 0 sec.	Own value (to be entered!)
		max.: 100 % / 32767 sec.	
		def.: 0 % / 0 sec.	
A target / actual value comparison can be undertaken with this function. The result is output via the field bus status word or a digital output. Parameter 6.070 can be used to define the tolerance range of the target value. Parameter 6.071 can be used to set the time for which the actual value has to be outside the tolerance range before the output is reset. Example: Operating mode = PID control PID target value = 50 % 6.070 = 10 % 6.071 = 1 sec. As soon as the actual value is between 40 % and 60 %, the output is set. If the actual value is outside 40 % to 60 % for 1 sec., the output is reset.			

1	2	3	4	5	6	7	8	9	10	11	12
---	---	---	---	---	---	---	---	---	----	----	----

5.4 Performance parameters

5.4.1 Motor data

33.001	Type of motor	Unit: integer	
Relationship to parameter: 33.010	Transfer status: 1	min.: 1	Own value (to be entered!)
		max.: 2	
		def.: 1	
Selection of type of motor. 1 = asynchronous motor 2 = synchronous motor The parameters are shown depending on the type of motor selected. The type of control (parameter 34.010) must also be selected.			

33.015	R optimisation	Unit: %	
Relationship to parameter:	Transfer status: 1	min.: 0	Own value (to be entered!)
		max.: 200	
		def.: 100	
If necessary, this parameter can be used to optimise the start-up behaviour.			

Parameter

1	2	3	4	5	6	7	8	9	10	11	12
---	---	---	---	---	---	---	---	---	----	----	----

33.016	Motor phase monitoring	Unit: integer
Relationship to parameter:	Transfer status: 1	min.: 0
		max.: 1
		def.: 1
Own value (to be entered!)		
<p>(V 03.72 and higher)</p> <p>The "Motor connection interrupted" error monitoring (error -45) can be disabled with this parameter.</p> <p>0 = Monitoring disabled 1 = Monitoring enabled</p>		

33.031	Motor current	Unit: A
Relationship to parameter: 5.070	Transfer status: 1	min.: 0
		max.: 150
		def.: 0
Own value (to be entered!)		
This is used to set the nominal motor current $I_{M,N}$ for either the star or triangle connection.		

33.032	Motor rating	Unit: W
Relationship to parameter:	Transfer status: 1	min.: 0
		max.: 55000
		def.: 0
Own value (to be entered!)		
A performance value [W] $P_{M,N}$ has to be set here that corresponds to the nominal motor rating.		

33.034	Motor speed	Unit: rpm
Relationship to parameter: 34.120 5.075	Transfer status: 1	min.: 0
		max.: 10000
		def.: 0
Own value (to be entered!)		
The value from the motor's type plate data has to be entered here for the nominal motor rotation speed $n_{M,N}$.		

33.035	Motor frequency	Unit: Hz
Relationship to parameter:	Transfer status: 1	min.: 10
		max.: 400
		def.: 0
Own value (to be entered!)		
This is where the nominal motor frequency $f_{M,N}$ is set.		

33.050	Stator resistance	Unit: Ohm
Relationship to parameter:	Transfer status: 1	min.: 0
		max.: 100
		def.: 0.001
Own value (to be entered!)		
The stator resistance can be optimised here, if the automatically determined value (motor identification) is insufficient.		

Parameter

1	2	3	4	5	6	7	8	9	10	11	12
---	---	---	---	---	---	---	---	---	----	----	----

33.105	Leakage inductance	Unit: H	
Relationship to parameter:	Transfer status: 1	min.: 0	Own value (to be entered!)
		max.: 1	
		def.: 0	
<p>Only for asynchronous motors. Here the leakage inductance can be optimised if the automatically calculated value (of motor identification) isn't sufficient.</p>			

33.110	Motor voltage	Unit: V	
Relationship to parameter:	Transfer status: 1	min.: 0	Own value (to be entered!)
		max.: 1500	
		def.: 0	
<p>Only for asynchronous motors. This is used to set the nominal motor voltage $U_{M,N}$ for either the star or triangle connection.</p>			

33.111	Motor cos phi	Unit: 1	
Relationship to parameter:	Transfer status: 1	min.: 0.5	Own value (to be entered!)
		max.: 1	
		def.: 0	
<p>Only for asynchronous motors. The value from the motor's type plate data has to be entered here for the power factor cos phi.</p>			

33.200	Stator inductance	Unit: H	
Relationship to parameter:	Transfer status: 1	min.: 0	Own value (to be entered!)
		max.: 1	
		def.: 0	
<p>For synchronous motors only. The stator inductance can be optimised here if the automatically determined value (motor identification) is insufficient.</p>			

33.201	Nominal flux	Unit: mVs	
Relationship to parameter:	Transfer status: 1	min.: 0	Own value (to be entered!)
		max.: 10000	
		def.: 0	
<p>For synchronous motors only. The nominal flux can be optimised here if the automatically determined value (motor identification) is insufficient.</p>			

1	2	3	4	5	6	7	8	9	10	11	12
---	---	---	---	---	---	---	---	---	----	----	----

5.4.2 I²t

33.010	I ² t fact. motor	Unit: %	
Relationship to parameter: 33.031 33.011	Transfer status: 2	min.: 0	Own value (to be entered!)
		max.: 1000	
		def.: 100	
The percentage current threshold (in relation to motor current 33.031) at the start of integration can be set here. 0 % = disable We recommend using winding protection contacts in heat-sensitive applications!			

33.011	I ² t time	Unit: s	
Relationship to parameter: 33.010	Transfer status: 2	min.: 0	Own value (to be entered!)
		max.: 1200	
		def.: 30	
Time after which the drive controller switches off with I ² t.			

33.138	Holding current time	Unit: s	
Relationship to parameter: 33.010	Transfer status: 2	min.: 0	Own value (to be entered!)
		max.: 3600	
		def.: 2	
Only for asynchronous motors. This is the time during which the drive is held at continuous current after the brake ramp has been completed.			

5.4.3 Switching frequency

The internal switching frequency can be changed in order to control the power element. A high setting reduces noise in the motor but results in increased EMC emissions and losses in the drive controller.

34.030	Switching frequency	Unit: Hz	
Relationship to parameter: 33.010	Transfer status: 2	min.: 1	Own value (to be entered!)
		max.: 4	
		def.: see data sheet	
Selection of the switching frequency for the drive controller: 1 = 16 kHz 2 = 8 kHz 4 = 4 kHz			

5.4.4 Controller data

34.010	Control method	Unit: integer	
Relationship to parameter: 33.001 34.011	Transfer status: 2	min.: 100	Own value (to be entered!)
		max.: 201	
		def.: 100	
Selection of the control method: 100 = open-loop asynchronous motor 200 = open-loop synchronous motor			

Parameter

1	2	3	4	5	6	7	8	9	10	11	12
---	---	---	---	---	---	---	---	---	----	----	----

34.020	Flying restart	Unit:	
Relationship to parameter: 34.021	Transfer status: 2	min.: 0	Own value (to be entered!)
		max.: 1	
		def.: 1	
This parameter can be used to activate the flying restart. 0 = disable 1 = enable			

34.021	Catch time	Unit: ms	
Relationship to parameter:	Transfer status: 2	min.: 0	Own value (to be entered!)
		max.: 10,000	
		def.: 100	
The catch time can be optimised here, if the automatically determined results (of the motor identification) are insufficient.			

34.090	Speed controller K_p	Unit: mA / rad / s	
Relationship to parameter:	Transfer status: 2	min.: 0	Own value (to be entered!)
		max.: 10000	
		def.: 150	
For asynchronous motors: The control boost of the speed controller can be optimised here, if the automatically determined results (of the motor identification) are insufficient. For synchronous motors: The control boost of the speed controller can be set here.			

34.091	Speed controller T_n	Unit: s	
Relationship to parameter:	Transfer status: 2	min.: 0	Own value (to be entered!)
		max.: 10	
		def.: 4	
For asynchronous motors: The reset time of the speed controller can be optimised here, if the automatically determined results (of the motor identification) are insufficient. For synchronous motors: The reset time of the speed controller must be optimised here, we would recommend a value between 0.1 s and 0.5 s.			

Parameter

1	2	3	4	5	6	7	8	9	10	11	12
---	---	---	---	---	---	---	---	---	----	----	----

34.110	Slip trimmer	Unit:	
Relationship to parameter: 5.080 33.034	Transfer status: 2	min.: 0	Own value (to be entered!)
		max.: 1.5	
		def.: 1	
Only for asynchronous motors. This parameter can be used to optimise or deactivate slippage compensation. 0 = disable (performance as on the grid) 1 = compensation for slippage. Example: 4 pole asynchronous motor at 1410 rpm, target frequency 50 Hz Motor idling 0 = approx. 1500 rpm 1 = 1500 rpm Motor at nominal point 0 = 1410 rpm 1 = 1500 rpm 50 Hz is always displayed as the actual frequency. Deactivating slip compensation may result in stall detection no longer working reliably.			

34.130	Voltage control reserve	Unit:	
Relationship to parameter:	Transfer status: 2	min.: 0	Own value (to be entered!)
		max.: 1	
		def.: 0.95	
Only for asynchronous motors. This parameter can be used to adjust voltage output.			

5.4.5 Quadratic characteristic curve

34.120	Quadratic characteristic curve	Unit: integer	
Relationship to parameter: 34.121	Transfer status: 2	min.: 0	Own value (to be entered!)
		max.: 1	
		def.: 0	
Only for asynchronous motors. The quadratic characteristic curve function can be activated here. 0 = disable 1 = enable			

34.121	Flux adjustment	Unit: %	
Relationship to parameter: 34.120	Transfer status: 2	min.: 0	Own value (to be entered!)
		max.: 100	
		def.: 50	
Only for asynchronous motors. The percentage by which the flux is to be reduced can be set here. An overvoltage shutdown can occur if there are any major changes in operation.			

1	2	3	4	5	6	7	8	9	10	11	12
---	---	---	---	---	---	---	---	---	----	----	----

5.4.6 Synchronous motor controller data

34.225	Field weakening	Unit: integer	
Relationship to parameter:	Transfer status: 2	min.: 0	Own value (to be entered!)
		max.: 1	
		def.: 0	
For synchronous motors only. 0 = disable, the motor cannot be run in the field weakening. 1 = enable, the motor can be placed in the field weakening until the drive controller has reached its current limit or the maximum permissible electromotive force.			

34.226	Starting current	Unit: %	
Relationship to parameter: 34.227	Transfer status: 2	min.: 5	Own value (to be entered!)
		max.: 1000	
		def.: 25	
For synchronous motors only. Here the current which was stamped in the motor before starting the control can be adjusted. Value as % of nominal motor current.			

34.227	Init time	Unit: s	
Relationship to parameter: 34.226	Transfer status: 2	min.: 0	Own value (to be entered!)
		max.: 100	
		def.: 0.25	
For synchronous motors only. Here the time during which the start up current 34.226 is stamped can be set.			

34.228 – 34.230	Start-up procedure	Unit: integer	
Relationship to parameter:	Transfer status: 2	min.: 0	Own value (to be entered!)
		max.: 1	
		def.: 0	
For synchronous motors only. By changing the start-up procedure to "Controlled", higher starting torques can be achieved. 0 = regulated, the drive controller directly to the control after the stamping phase. 1 = controlled, after the stamping phase the rotation field is increased by the control with start ramp 34.229 up to start frequency 34.230, then switched to the controller.			

36.020	Deact grid monitoring	Unit: integer	
Relationship to parameter:	Transfer status: 2	min.: 0	Own value (to be entered!)
		max.: 1	
		def.: 0	
(V 03.84 and higher) Grid monitoring can be deactivated here. 0: deactivated 1: activated			

6. Error detection and troubleshooting

This chapter contains the following:

- a list of the LED flash codes for error recognition
- a description of error recognition using PC tools
- a list of errors and system errors
- notes on error detection with the MMI

DANGER!



Risk of death due to electrical shock!

Death or serious injury!

De-energise drive controller and secure it against being restarted.

If damaged parts or components need replacing, only ever replace with original parts.



Danger due to electrical shock and discharge. Wait two minutes (discharge time of the capacitors) after shut-down.

6.1 List of the LED flash codes for error recognition

When an error occurs, the LEDs on the drive controller display a flashing code that allows the errors to be diagnosed.

The following table contains an overview:

Red LED	Green LED	State
		Boot loader active (flashing in turn)
		Ready for operation (activate En_HW for operation)
		Operation / ready
		Warning
		Error
		Identification of motor data
		Initialisation
		Firmware update
		Bus error operation
		Bus error ready for operation

Tab. 17: LED flash codes

Key			
	LED off		LED on
	LED flashing		LED flashing quickly

1	2	3	4	5	6	7	8	9	10	11	12
---	---	---	---	---	---	---	---	---	----	----	----

6.2 List of errors and system errors

The driver controller shuts down if an error occurs. Consult the flash code table / PC tool for the corresponding error numbers.



IMPORTANT INFORMATION

Error messages can only be acknowledged once the error has been remedied.

Error messages can be acknowledged as follows:

- digital input (can be programmed)
- using MMI (handheld controller)
- [Automatic acknowledgement function](#) (Parameter 1.181)
- switch device off and on again

via fieldbus (CANOpen, Profibus DP, EtherCAT)



IMPORTANT INFORMATION

Errors must always be rectified before acknowledgement, otherwise the drive controller may be damaged.

The following section contains a list of possible error messages.

Please contact the BRINKMANN service department if you encounter errors that are not listed here.

No.	Error name	Description of error	Possible causes/remedy
1	Undervoltage 24 V application	Supply voltage for the application is less than 15 V	24 V supply overload
2	Overvoltage 24 V application	Supply voltage for the application is greater than 31 V	Internal 24 V supply is not OK or external supply is not OK
4	Warning: Customer PLC runtime environment	The customer PLC is not running	The customer PLC is being downloaded / The customer PLC has a programming error, e.g. division by 0
6	Customer PLC version error	The version of the customer PLC doesn't match the device firmware	Check the version numbers of the customer PLC and device firmware
8	Communication application<->power	Internal communication between the application plate and the power-conducting plate is not OK	EMC interference
10	Parameter distributor	The internal distribution of parameters during initialisation failed	Parameter set is incomplete
11	Time-out power	The power part does not respond	Operation with 24 V without mains feed-in
13	Cable break at analogue in1 (4–20 mA / 2–10 V)	Current or voltage is less than the lower limit of analogue input 1 (monitoring for this error is activated automatically by setting parameter 4.021 to 20 %).	Cable break, faulty external sensor
14	Cable break at analogue in 2 (4–20 mA / 2–10 V)	Current or voltage is less than the lower limit of analogue input 2 (monitoring for this error is activated automatically by setting parameter 4.021 to 20 %)	Cable break, faulty external sensor
15	Blocking detection	The drive shaft of the motor is stalled. 5,080	Remove the blockage
16	PID dry run	No PID actual value despite maximum speed	PID actual value sensor defective. Extend dry run time parameter 3.072

Continues on next page

1	2	3	4	5	6	7	8	9	10	11	12
---	---	---	---	---	---	---	---	---	----	----	----

Continuation

No.	Error name	Description of error	Possible causes/remedy
17	Start-up error	Motor not starting up or starting up incorrectly. 5,082	Check motor connections/check motor and controller parameters; if necessary, disable error (5.082).
18	Excess temperature for FC application	Inner temperature too high	Insufficient cooling, low motor speed and high torque, switching frequency too high.
19	Firmware update error	A firmware update could not be completed	Disconnection during a firmware update. Repeat the firmware update The FKO is supplied externally with 24V. Note: During a firmware update, no external 24V may be connected.
21	Bus time-out	Bus communication abort, the bus timeout time (6.062) no telegrams were received.	Check external wiring. Check fieldbus communication. Increase bus timeout time.
21	Bus time-out	No response from bus sharing unit or MMI/PC	Check bus wiring
22	Acknowledgement error	The number of maximum automatic acknowledgements (1.182) was exceeded	Check error history and remedy error
23	External fault 1	The parameterised fault input is active. 5,010	Correct the external fault
24	External fault 2	The parameterised fault input is active. 5,011	Correct the external fault
25	Motor detection	Motor identification error	Check FKO/motor and PC / MMI / FKO connections / restart motor identification
26	STO inputs plausibility	The statuses of the two STO inputs have not been identical for more than 2 sec.	Incorrect activation of the STO inputs. Check corresponding external wiring.
28	Limit frequency exceeded / not met	The parameterised minimum / maximum frequency has not been met / has been exceeded.	The parameterised time 5.085 or 5.086 is too short / Motor blocked / Brake not opened / Motor overloaded
32	Trip IGBT **	Protection of the IGBT module against overcurrent has been triggered	Short circuit in the motor or motor feed line / controller settings
33	Overvoltage of intermediate circuit **	The maximum intermediate circuit voltage has been exceeded	Feedback by motor in generator mode / mains voltage too high / faulty setting for rotation speed controller / brake resistor not connected or defective / ramp times too short
34	Undervoltage of intermediate circuit	The minimum intermediate circuit voltage has not been reached	Mains voltage too low, mains connection defective / check wiring
35	Excess motor temperature	Motor PTC has been triggered	Overload of the motor (e.g. high torque at low motor speed) / ambient temperature too high

Continues on next page

1	2	3	4	5	6	7	8	9	10	11	12
---	---	---	---	---	---	---	---	---	----	----	----

Continuation

No.	Error name	Description of error	Possible causes/remedy
36	Power failure	The grid voltage has dropped briefly	Grid fluctuation / grid voltage interrupted
38	Excess IGBT module temperature	Excess IGBT module temperature	Insufficient cooling, low motor speed and high torque, switching frequency too high
39	Overcurrent **	Maximum output current of drive controller exceeded	Motor stalled / check motor connection / incorrect speed controller setting / check motor parameters / ramp times too short / brake not open
40	Excess frequency converter temperature	Inner temperature too high	Insufficient cooling / low motor speed and high torque / switching frequency too high permanent overload / reduce ambient temperature / check fan
42	I ² t motor protection shut-off	The internal I ² t motor protection (can be parametrised) has been triggered	Permanent overload
43	Ground leak **	Ground leak during a motor phase	Insulation fault
45	Motor connection disrupted	No motor current in spite of control through frequency converter	No motor connected or not completely connected. Check phases or motor connections and connect correctly when necessary. *
46	Motor parameters	Plausibility check for motor parameters failed	Parameter set not OK
47	Drive controller parameters	Plausibility check for drive controller parameters failed	Parameter set not OK, motor type 33.001 and control method 34.010 not plausible.
48	Type plate data	No motor data entered	Please enter the motor data according to the type plate
49	Power class restriction	Max. overload of the drive controller exceeded for more than 60 sec.	Check application / reduce load / use larger drive controller.
53	Motor tipped	Only for synchronous motors, field orientation lost	Load too high. Optimise controller parameters.

Tab. 18: Error detection

* In exceptional cases, the error may be displayed erroneously for idling (very low motor current) synchronous motors.
Set parameter 33.016 accordingly when the phases or motor connections are connected correctly.

** Should the error occur again, depending on frequency, it can only be acknowledged after the following times:

- 1 -3 acknowledgements permitted = 1 s waiting time
- 4 -5 acknowledgements permitted = 5 s waiting time
- > 5 acknowledgements permitted = 30 s waiting time

The number of acknowledgements is deleted after 120 s without any errors!

7. Disassembly and disposal

This chapter contains the following:

- a description of how to disassemble the drive controller
- information on correct disposal

7.1 Drive controller disassembly

DANGER!



Risk of death due to electrical shock!

Death or serious injury!

De-energise drive controller and secure it against being restarted.



Danger due to electrical shock and discharge. Wait two minutes (discharge time of the capacitors) after shut-down.

1. Open drive controller cover.
2. Release cables at terminals.
3. Remove all cables.
4. Remove connection screws for drive controller / adapter plate.
5. Remove drive controller.

7.2 Information on correct disposal

Dispose of drive controller, packaging and replaced parts in accordance with the regulations of the country in which the drive controller has been installed.

The drive controller may not be disposed of with household waste.

8. Technical data

8.1 General data

8.1.1 General technical data for 400V devices

Size	A				B			C		D			
Recommended motor rating ¹⁾ [kW]	0.55	0.75	1.1	1.5	2.2	3.0	4.0	5.5	7.5	11.0	15.0	18.5	22.0
Supply voltage	3 x 200 V AC -10 %...480 V AC +10 % 280 V DC -10 %...680 V DC +10 % ⁴⁾												
Grid frequency	50/60 Hz ± 6 %												
Network configurations	TN / TT												
Line current [A]	1.4	1.9	2.6	3.3	4.6	6.2	7.9	10.8	14.8	23.2	28.2	33.2	39.8
Rated current output eff. [IN at 8 kHz]	1.7	2.3	3.1	4.0	5.6	7.5	9.5	13.0	17.8	28.0	34.0	40.0	48.0
Min. brake resistance [Ω]	100				50			50		30			
Overload for 60 sec. in %	150												130
Switching frequency	4 kHz, 8 kHz, 16 kHz, (factory setting 8 kHz)								4 kHz - 16 kHz, (factory setting 4 kHz)				
Output frequency	0 Hz - 400 Hz												
Nominal output apparent power [kVA]	1.06	1.43	1.93	2.49	3.49	4.68	5.92	8.11	11.1	17.46	21.20	24.94	29.93
Mains cycles of operation / restart										2 min.			
DIN EN 61800-5 touch current	< 3,5 mA ²⁾												
Protective function	Overvoltage and undervoltage, I ² t restriction, short-circuit, ground leak, motor and drive controller temperature, stall prevention, blocking detection, PID dry run protection												
Software functions	Process control (PID controller), fixed frequencies, data record changeover, flying restart, motor current limit												
Soft PLC	IEC61131-3, FBD, ST, AWL												
Housing	Two-part aluminium die-cast casing												
Dimensions [L x W x H] mm	233 x 153 x 120				270 x 189 x 140			307 x 223 x 181		414 x 294 x 232			
Weight including adapter plate	3.9 kg				5.0 kg			8.7 kg		21.0 kg			
Protection class [IPxy]	IP 65									IP 55			
Cooling	Passive cooling									Active cooling			
Ambient temperature	- 40 °C (non-condensing) to + 50 °C (without derating)									-40 °C bis +50 °C (8 kHz)		-40 °C bis +50 °C (4 kHz)	
Storage temperature	-40 °C...+85 °C												
Altitude of the installation location	up to 1000 m above sea level/over 1000 m with reduced performance (1% per 100 m) / above 2000 m see chapter 8.2.2												
Relative air humidity	≤ 96 %, condensation not permitted												
Vibration resistance (DIN EN 60068-2-6)	50 m/s ² ; 5...200 Hz ³⁾												
Shock resistance (DIN EN 60068-2-27)	300 m/s ²												
EMC (DIN-EN-61800-3)	C2												
Energy efficiency class (EN 61800-9-2)	IE2												

Technical data for FKO M 400 V devices (subject to technical changes)

¹⁾ Recommended motor rating (4-pole asynchronous motor) is specified based on the 400 VAC supply voltage.

²⁾ With 1LA7 asynchronous motor, motor-mounted

³⁾ Combined vibration test, part 4, severity 2 in accordance with FN942017

⁴⁾ In compliance with the overvoltage category

⁵⁾ < 3 s may result in power failure/intermediate circuit undervoltage faults

1	2	3	4	5	6	7	8	9	10	11	12
---	---	---	---	---	---	---	---	---	----	----	----

8.1.2 General technical data for 230 V devices

Size		A				
Electrical data	Recommended motor rating ¹⁾ [kW]	0.37	0.55	0.75	1.1	1.5
	Supply voltage	1 x 100 V AC -15 %...230 V AC +10 % 140 VDC - -15 %...320 VDC + +10 %				
	Grid frequency	50/60 Hz ± 6 %				
	Network configurations	TN / TT				
	Line current [A]	4.5	5.6	6.9	9.2	13.2
	Rated current output eff. [IN at 8 kHz]	2.3	3.2	3.9	5.2	7
	Min. brake resistance [Ω]	50				
	Overload for 60 sec. in %	150				125
	Switching frequency	4 kHz, 8 kHz, 16 kHz, (factory setting 8 kHz)				
	Output frequency	0 Hz – 400 Hz				
	Mains cycles of operation / restart	Every 2 min.				
	DIN EN 61800-5 touch current	< 10 mA ²⁾				
	Functions	Protective function	Overvoltage and undervoltage, I ² t restriction, short-circuit, ground leak, motor and drive controller temperature, stall prevention, blocking detection, PID dry run protection			
Software functions		Process control (PID controller), fixed frequencies, data record changeover, flying restart, motor current limit				
Soft PLC		IEC61131-3, FBD, ST, AWL				
Mechanical data	Housing	Two-part aluminium die-cast casing				
	Dimensions [L x W x H] mm	233 x 153 x 120				
	Weight including adapter plate	3.9 kg				
	Protection class [IPxy]	IP 65				
	Cooling	Passive cooling				Active internal cooling
Environmental conditions	Ambient temperature	-10 °C (non-condensing) to +40 °C (50 °C with derating)				up to 35 °C/ 40 °C ⁴⁾
	Storage temperature	-25 °C...+85 °C				
	Altitude of the installation location	up to 1000 m above sea level/over 1000 m with reduced performance (1% per 100 m) / above 2000 m see chapter 8.2.2				
	Relative air humidity	≤ 96 %, condensation not permitted				
	Vibration resistance (DIN EN 60068-2-6)	50 m/s ² ; 5...200 Hz ³⁾				10 m/s ² 5...200 Hz ³⁾
	Shock resistance (DIN EN 60068-2-27)	300 m/s ²				100 m/s ²
	EMC (DIN-EN-61800-3)	C1				

Technical data for FKO M 230 V devices (subject to technical changes)

¹⁾ Recommended motor rating (4-pole asynchronous motor) is specified based on the 230 VAC supply voltage.

²⁾ With 1LA7 asynchronous motor, motor-mounted

³⁾ Combined vibration test, part 4, severity 2 in accordance with FN942017

⁴⁾ For 40 m³/h / 60 m³/h cooling air flow

1	2	3	4	5	6	7	8	9	10	11	12
---	---	---	---	---	---	---	---	---	----	----	----

8.1.3 Specification of interfaces

Designation	Function
Digital inputs 1 – 4	<ul style="list-style-type: none"> - Switching level low < 2 V / high > 18 V - I_{max} (at 24 V) = 3 mA - R_{in} = 8.6 kOhm
Hardware approval for input	<ul style="list-style-type: none"> - Switching level low < 3 V / high > 18 V - I_{max} (at 24 V) = 8 mA
Analogue inputs 1, 2	<ul style="list-style-type: none"> - I_n +/- 10 V or 0 – 20 mA - I_n 2 – 10 V or 4 – 20 mA - 10-bit resolution - Tolerance +/- 2 % Voltage input: <ul style="list-style-type: none"> - R_{in} = 10 kOhm Current input: <ul style="list-style-type: none"> - Working resistance = 500 Ohm
Digital outputs 1, 2	<ul style="list-style-type: none"> - Short-circuit proof - I_{max} = 20 mA
Relays 1, 2	<p>1 changeover contact (NO/NC) Maximum switching power *</p> <ul style="list-style-type: none"> - at ohmic load (cos 1): = 5 A at ~ 230 V or = 30 V - at inductive load (cos 0,4 and L/R = 7 ms): = 2 A at ~ 230 V or = 30 V <p>Maximum reaction time: 7 ms ± 0.5 ms Electric life: 100 000 switching cycles</p>
Analogue output 1 (current)	<ul style="list-style-type: none"> - Short-circuit proof - I_{out} = 0.. 20 mA - Working resistance = 500 Ohm - Tolerance +/- 2 %
Analogue output 1 (voltage)	<ul style="list-style-type: none"> - Short-circuit proof - U_{out} = 0..10 V - I_{max} = 10 mA - Tolerance +/- 2 %
Power supply 24 V	<ul style="list-style-type: none"> - Auxiliary voltage U = 24 V DC - SELV - Short-circuit proof - I_{max} = 100 mA - external feeding of 24 V possible
Power supply 10 V	<ul style="list-style-type: none"> - Auxiliary voltage U = 10 V DC - Short-circuit proof - I_{max} = 30 mA

Tab. 19: Specification of interfaces

* in terms of the UL 508C standard, the maximum allowed is 2 A!

1	2	3	4	5	6	7	8	9	10	11	12
---	---	---	---	---	---	---	---	---	----	----	----

8.1.4 Power loss table

FKO M Variant	Supply voltage [V]	Rated output current [A]	Measurement (90; 100)	Measurement (50; 100)	Measurement (10; 100)	Measurement (90; 50)	Measurement (50; 50)	Measurement (10; 50)	Measurement (50; 25)	Measurement (10; 25)	Standby losses [W]	IE-class
			Power loss absolute [W] ^{1) 2)}									
			Losses relative [%] ^{1) 2) 3)}									
			20	19	21	19	17	18	16	18		
Size A 0,55 kW	400	1,7	1,9	1,8	2	1,8	1,6	1,7	1,5	1,7	5	IE2
			26	25	26	19	19	21	19	20		
Size A 0,75 kW	400	2,3	1,8	1,8	1,8	1,3	1,3	1,4	1,3	1,4	5	IE2
			33	33	32	24	26	25	19	21		
Size A 1,1 kW	400	3,1	1,7	1,7	1,6	1,3	1,4	1,3	1	1,1	5	IE2
			45	38	41	29	31	30	32	26		
Size A 1,5 kW	400	4,0	1,8	1,5	1,6	1,2	1,2	1,2	1,3	1	5	IE2
			58	55	56	42	40	42	32	37		
Size B 2,2 kW	400	5,6	1,7	1,6	1,6	1,2	1,1	1,2	0,9	1	5	IE2
			81	87	71	54	53	52	43	46		
Size B 3,0 kW	400	7,5	1,7	1,9	1,5	1,2	1,1	1,1	0,9	1	5	IE2
			103	96	94	67	62	64	53	53		
Size B 4,0 kW	400	9,5	1,7	1,6	1,6	1,1	1	1,1	0,9	0,9	5	IE2
			153	125	123	77	73	73	53	58		
Baugröße C 5,5 kW	400	13,0	1,9	1,5	1,5	0,9	0,9	0,9	0,7	0,7	5	IE2
			233	187	171	104	95	95	74	81		
Size C 7,5 kW	400	17,8	2,1	1,7	1,5	0,9	0,9	0,9	0,7	0,7	5	IE2
			268	234	242	152	140	150	107	116		
Size D 11,0 kW	400	28,0	1,5	1,3	1,4	0,9	0,8	0,9	0,6	0,7	13	IE2
			339	293	297	185	165	174	123	133		
Size D 15,0 kW	400	34,0	1,6	1,4	1,4	0,9	0,8	0,8	0,6	0,6	13	IE2
			407	347	347	212	189	200	135	147		
Size D 18,5 kW	400	40,0	1,6	1,4	1,4	0,9	0,8	0,8	0,5	0,6	13	IE2
			526	448	448	262	237	248	172	183		
Size D 22,0 kW	400	48,0	1,8	1,5	1,5	0,9	0,8	0,8	0,6	0,6	13	IE2

- 1) Loss values at 4 kHz switching frequency
- 2) Loss values include a 10% surcharge according to the guideline
- 3) Relative losses based on the nominal apparent output power of the device

1	2	3	4	5	6	7	8	9	10	11	12
---	---	---	---	---	---	---	---	---	----	----	----

8.2 Derating of output power

Drive controllers of the FKO series have two integrated PTC resistors as standard which monitor both the heat sink temperature and the inner temperature. As soon as a permissible IGBT temperature of 95°C or a permissible inner temperature of 85°C is exceeded, the drive controller shuts down.

With the exception of the 22kW controller (size D 130%), all FKO type drive controllers are designed for an overload of 150% for 60sec (every 10min).

Reductions in the ability to handle overload and/or its duration should be taken into account in the following circumstances:

- A switching frequency permanently set too high >8 kHz (load-dependent).
- A permanently increased heat sink temperature, caused by a blocked air flow or a thermal blockage (dirty cooling ribs).
- Depending on the type of assembly, permanently excessive ambient temperature.

The respective max. output values can be determined from the following characteristic curves.

8.2.1 Derating due to increased ambient temperature

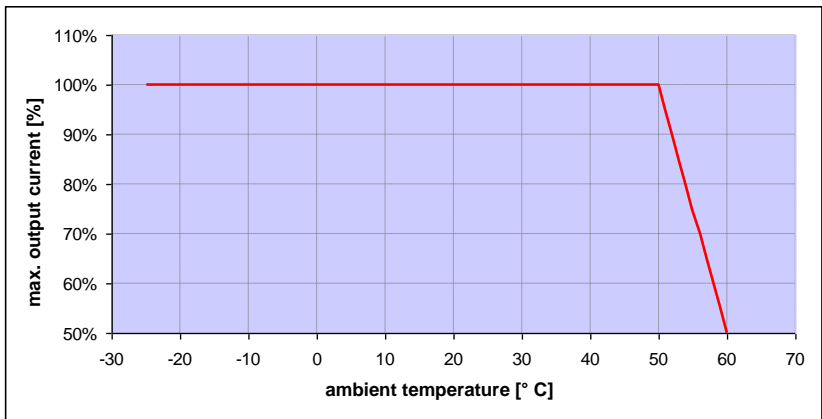

Fig. 37: Derating for drive controller fitted on motor (all sizes)

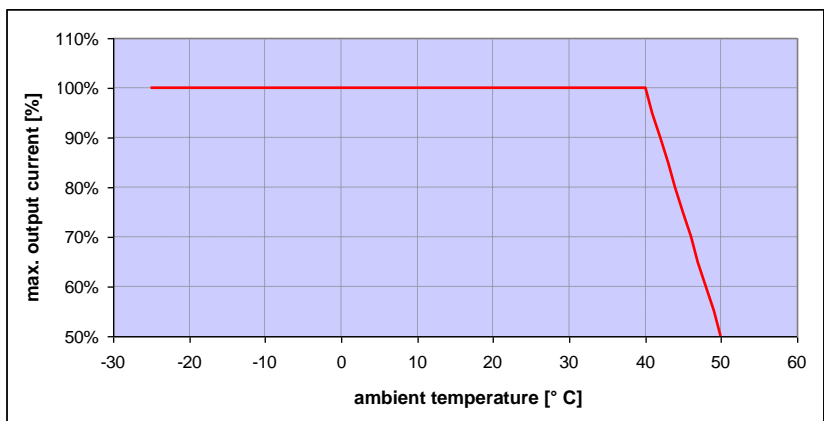

Fig. 38: Derating for drive controller fitted on wall (sizes A - C)

Continues on next page

1	2	3	4	5	6	7	8	9	10	11	12
---	---	---	---	---	---	---	---	---	----	----	----

Continuation

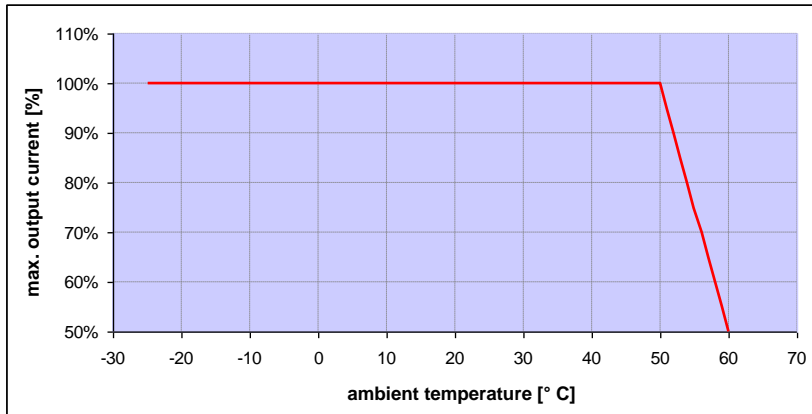

Fig. 39: Derating for wall-mounted drive controller (size D with fan option)

8.2.2 Derating due to installation altitude

The following applies to all FKO drive controllers:

- No reduction in performance is needed in S1 mode up to 1000m above sea level.
- A reduction in performance of 1% every 100 m is needed from 1000m \geq 2000m. Overvoltage category 3 is observed!
- Overvoltage category 2 should be observed from 2000 m \geq 4000 m because of the lower air pressure!

In order to observe the overvoltage category:

- use external overvoltage protection in the FKO's mains cable.
- reduce the input voltage.

Please contact the BRINKMANN Service department.

The respective max. output values can be determined from the following characteristic curves.

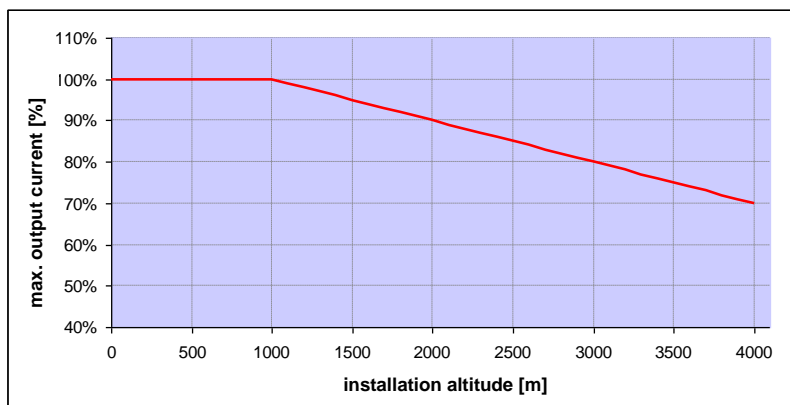

Fig. 40: Derating of maximum output current as a result of installation altitude

Continues on next page

1	2	3	4	5	6	7	8	9	10	11	12
---	---	---	---	---	---	---	---	---	----	----	----

Continuation

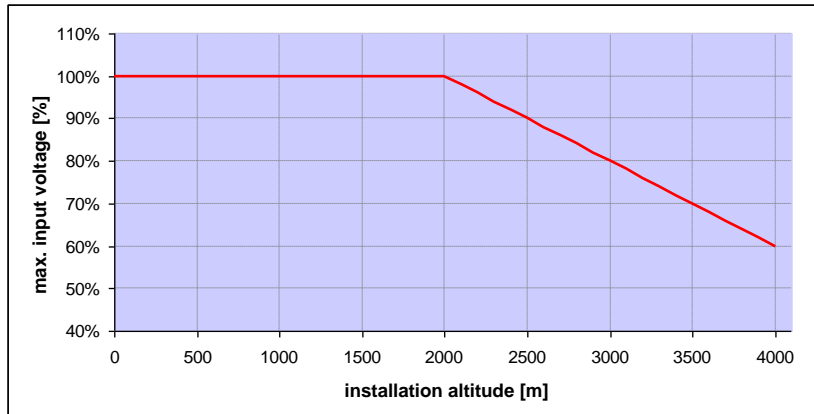

Fig. 41: Derating of maximum input voltage as a result of installation altitude

8.2.3 Derating due to switching frequency

The following diagram shows the output current, depending on switching frequency. To limit the thermal losses in the drive controller, the output current must be reduced.

Note: The switching frequency is not reduced automatically!

The max. output values can be determined from the following characteristic curve.

FKO M BG. A – D (0.37 kW – 15 kW)

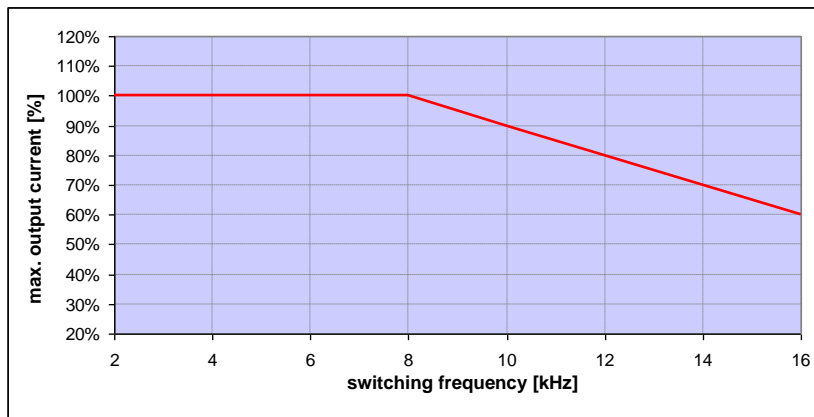

Fig. 42: Derating of maximum output current as a result of switching frequency (0.37 kW – 15 kW)

Continues on next page

1	2	3	4	5	6	7	8	9	10	11	12
---	---	---	---	---	---	---	---	---	----	----	----

Continuation

FKO M BG. D (18.5 kW)

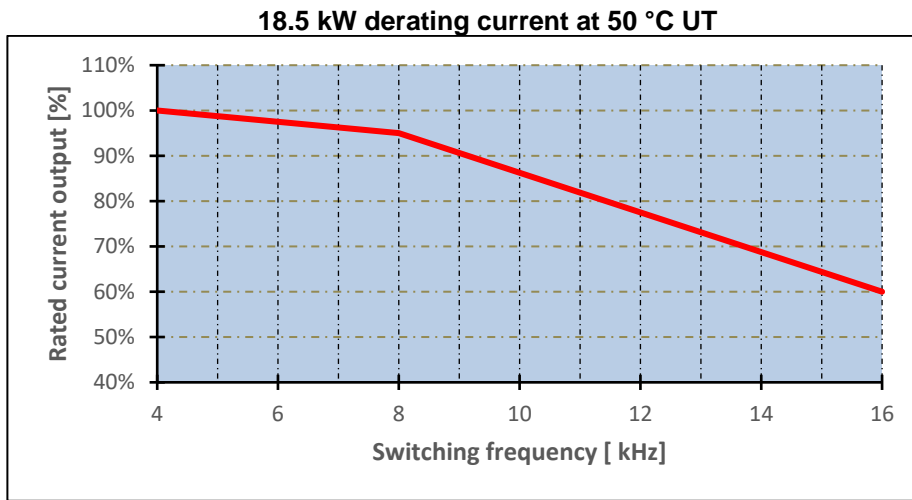

Fig. 43: Derating of the maximum output current due to the clock frequency (Variant 18.5 kW)

FKO M BG. D (22 kW)

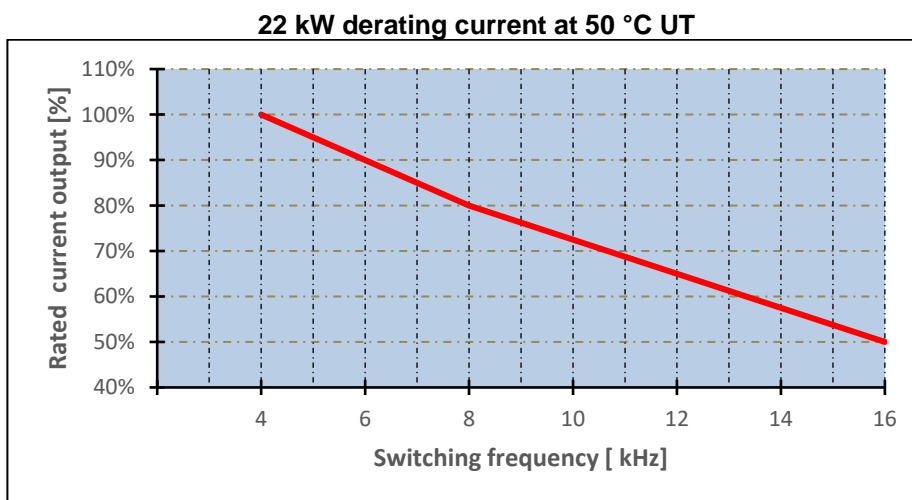

Fig. 44: Derating of the maximum output current due to the clock frequency (Variant 22 kW)

1	2	3	4	5	6	7	8	9	10	11	12
---	---	---	---	---	---	---	---	---	----	----	----

9. Optional accessories

This chapter contains brief descriptions of the following optional accessories

- Adapter plates
- MMI handheld controller including connection cable RJ9 on M12 plug
- Brake resistors

9.1 Adapter plates

9.1.1 Wall adapter plates (standard)

A standard wall adapter plate (with an integrated terminal board for sizes A to C) is available for each FKO size.

Four holes for mounting the adapter plate, as well as an EMC screw connection, are already featured.

FKO size	A	B	C	D
Power [kW]	0.55 to 1.9	2.2 to 4.0	5.0 to 9.0	11.0 to 22.0
Art. no.	6UMZU0AL-K07403	6UMZU0AL-K07406	6UMZU0AL-K07401	6UMZU0AL-K08119

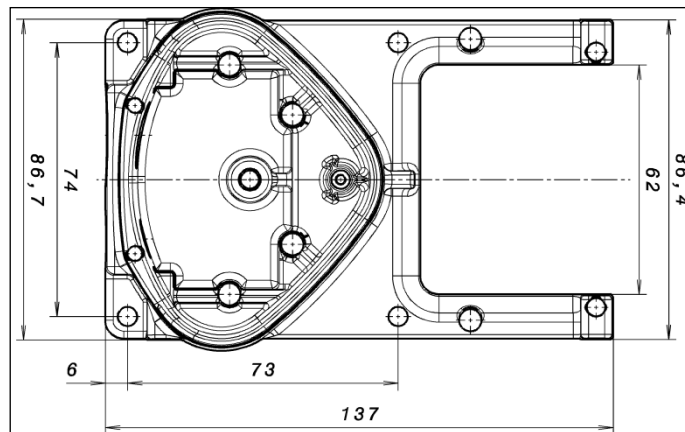

Fig. 45: Hole pattern for size A standard wall adapter plate

1

2

3

4

5

6

7

8

9

10

11

12

9.2 MMI handheld controller including a 3 m RJ9 connection cable with M12 plug



IMPORTANT INFORMATION

The MMI handheld controller (part. no. 6UMZU0AA-K07323) may only ever be used with an FKO!

The MMI handheld controller is connected to the integrated FKO M12 interface. This operating unit allows the user to write (program) and/or to visualise all the parameters of the FKO. Up to 8 complete data sets can be stored in an MMI and copied to other FKOs.

Complete commissioning is possible as an alternative to the free FKOpC software.

External signals are not needed.

9.3 PC communication cable USB on M12/RS485 plug (converter integrated)

As an alternative to the MMI handheld controller, an FKO can also be put into operation using the PC communication cable (art no. . 6UMZU0AA-K07324) and the FKOpC software. The FKOpC software is available free of charge from the BRINKMANN homepage at www.brinkmannpumps.de/Support/Downloads/Frequenzumrichter

10.Approvals, standards and guidelines

This chapter contains information about electromagnetic compatibility (EMC), and applicable guidelines, norms and standards.

For binding information about the relevant drive controller approvals, please refer to the relevant type plate!

10.1 EMC limit classes

Please note that the EMC limit value classes specified below are only achieved if the standard switching frequency, as set at the factory, is adhered to.

Depending on the installation material used and/or extreme ambient conditions, it might be necessary to use additional sheath wave filters (ferrite rings). In the event of wall mounting, the following cable lengths must not be exceeded

FKO size	Cable type	EMC class (DIN-EN-61800-3)	Max. length
A 1 AC (0.37 kW - 1.5 kW)	Shielded motor cable	C1	3 m
	Shielded motor cable	C2	5 m
	Unshielded motor cable	-	5 m
	A 3 AC (0.55 kW - 1.5 kW)	Shielded motor cable	C2
Shielded motor cable		C3	5 m
	Unshielded motor cable	-	5 m
	B (4 kW - 5.5 kW)	Shielded motor cable	C2
Shielded motor cable		C3	5 m
	Unshielded motor cable	-	5 m
	C (5.5 kW - 7.5 kW)	Shielded motor cable	C2
Shielded motor cable		C3	20 m
	Unshielded motor cable	-	100 m
	D (11 kW - 22 kW)	Shielded motor cable	C2
Shielded motor cable		C3	20 m
	Unshielded motor cable	-	100 m



IMPORTANT INFORMATION

- In a residential environment, this product can cause high-frequency disturbances that may require interference suppression measures.
- Wiring suitable for EMC also requires that EMC screw connections be used on both sides (drive controller and motor).
- If unshielded cables are used, certain EMC requirements may not be met in all circumstances, and additional EMC measures will therefore be required.



IMPORTANT INFORMATION

The cable for connecting the PTC must not exceed 5 m, otherwise the factory-fitted bridge must remain in use. For monitoring of the motor temperature, we would then recommend:

- the integrated I²t function.
- the use of an external PTC evaluation unit that can be evaluated via the FKO.

1	2	3	4	5	6	7	8	9	10	11	12
---	---	---	---	---	---	---	---	---	----	----	----

10.2 Classification acc. to IEC/EN 61800-3

The generic standard defines test procedures and severity levels for every environment in the drive controller category; these have to be complied with.

Definition of environment

First environment (residential, commercial and industrial area):

All “areas” that are directly supplied by a public low-voltage connection, such as:

- residential area, e.g. houses, apartments etc.
- retail area, e.g. shops, supermarkets
- public institutions, e.g. theatres, stations
- outside areas, e.g. petrol stations and parking areas
- light industry, e.g. workshops, laboratories, small businesses

Second environment (industry):

Industrial environments with their own supply network that is separated from the public low-voltage supply by a transformer.

10.3 Harmonics currents and grid impedance for devices > 16 A and ≤ 75 A

Extract from EN 61000-3-12, applies to devices with a rated current > 16 A and ≤ 75 A, which are intended for connection to public low-voltage grids.

<p>This device complies with IEC 61000-3-12 provided that the short-circuit power S_{SC} at the point where the customer's system connects with the public grid is greater than or equal to $R_{SCE} \times S_{equ}$. If found to be necessary after contacting the distributor grid operator, the installer or operator of the device is responsible for ensuring that the device is only connected at a point with a short-circuit power S_{sc} greater than or equal to $R_{SCE} \times S_{equ}$.</p>	
R_{sc}	Grid's short-circuit power at point where customer's system connects with the public grid.
S_{equ}	Rated apparent power for three-phase devices: $S_{equ} = \sqrt{3} \times U_l \times I_{equ}$ (U_l = external wire voltage, see technical data → supply voltage) (I_{equ} = rated current of device, see technical data → line current)
R_{SCE}	Short-circuit power relation For these devices: $R_{SCE} \geq 350$

10.4 Standards and guidelines

The following specifically apply:

- Directive 2014/53/EU - Radio Equipment Directive (OJ L 153 from 22.05.2014, p. 62) *
- Directive 2011/65/EU - RoHS Directive (OJ L 174 from 01.07.2011, p. 88)

* The basic requirements of the Low Voltage Directive and EMC Directive are also met here.

1	2	3	4	5	6	7	8	9	10	11	12
---	---	---	---	---	---	---	---	---	----	----	----

10.5 UL approval

10.5.1 UL Specification (English version)

Maximum Ambient Temperature:

Electronic	Adapter	Ambient	Suffix
INV M A IV02 PW02	ADP MA WDM	45° C	-
INV M A IV02 PW03	ADP MA WDM	45° C	-
INV M A IV02 PW04	ADP MA WDM	45° C	-
INV M A IV02 PW05	ADP MA WDM	40° C	-
INV M A IV02 PW90	ADP MA WDM	- *	-
INV M A IV01 PW03	ADP MA WDM	40° C	-
INV M A IV01 PW04	ADP MA WDM	40° C	-
INV M A IV01 PW05	ADP MA WDM	40° C	-
INV M A IV01 PW06	ADP MA WDM	40° C	-
INV M B IV01 PW07	ADP MB WDM	45° C	-
INV M B IV01 PW08	ADP MB WDM	40° C	-
INV M B IV01 PW09	ADP MB WDM	35° C	-
INV M C IV01 PW10	ADP MC WDM	40° C	GH01, GH02, GH07, GH93, GH95, GH4x
INV M C IV01 PW11	ADP MC WDM	35° C	GH01, GH02, GH07, GH93, GH95, GH4x
INV M C IV01 PW96	ADP MC WDM	35° C	GH01, GH02, GH07, GH93, GH95, GH4x
INV M C IV01 PW97	ADP MC WDM	20° C	GH01, GH02, GH07, GH93, GH95, GH4x
INV M C IV01 PW10	ADP MC WDM	55° C	GH04, GH96, GH5x
INV M C IV01 PW11	ADP MC WDM	50° C	GH04, GH96, GH5x
INV M C IV01 PW96	ADP MC WDM	50° C	GH04, GH96, GH5x
INV M C IV01 PW10	ADP MC WDM	50° C	GH05, GH97, GH6x
INV M C IV01 PW11	ADP MC WDM	45° C	GH05, GH97, GH6x
INV M C IV01 PW96	ADP MC WDM	45° C	GH05, GH97, GH6x
INV M D IV01 PW12	ADP MD WDM	55° C	-
INV M D IV01 PW13	ADP MD WDM	50° C	-
INV M D IV01 PW14	ADP MD WDM	40° C	-
INV M D IV01 PW15	ADP MD WDM	35° C	-

* depends on external cooling

Required Markings

Enclosure intended for use with field-installed conduit hubs, fittings or closure plates UL approved in accordance to UL514B and CSA certified in accordance to C22.2 No. 18, environmental Type 1 or higher.

Internal Overload Protection Operates within 60 seconds when reaching 150 % of the Motor Full Load Current.

1	2	3	4	5	6	7	8	9	10	11	12
---	---	---	---	---	---	---	---	---	----	----	----

Short circuit current rating (SCCR)

Suitable for use on a circuit capable of delivering not more than 200 kA rms symmetrical amperes, 230 Volts for INV Mx IV02 or 480 Volts for INV Mx IV01, maximum when protected by fuses.

“Warning” – Use fuses rated 600 V/50 A for INV MA IV02 only.

“Warning” – Use fuses rated 600 V/10 A for INV MA IV01 only.

“Warning” – Use fuses rated 600 V/30 A for INV MB IV01 only.

“Warning” – Use fuses rated 600 V/30 A for INV MC IV01 only.

“Warning” – Use fuses rated 600 V/70 A for INV MD IV01 only.

CAUTION: Integral solid state short circuit protection does not provide branch circuit protection. Branch circuit protection must be provided in accordance with the Manufacturer Instructions, National Electrical Code and any additional local codes.

All wiring terminals marked to indicate proper connections for the power supply, load and control circuitry.

The tightening, torque to connect the motor terminals, is 26.55 lb/in (size A to C) and 5.31 lb/in to connect the PTC (in all sizes).

Instruction for operator and servicing instructions on how to mount and connect the products using the intended motor connection adapter, please see chapter 3.3 and 9.1 in the operating manual.

CAUTION: Use 75° C copper wires only.

Drives do not provide over temperature sensing.

CAUTION: For Mx IV01 used in Canada: TRANSIENT SURGE SUPPRESSION SHALL BE INSTALLED ON THE LINE SIDE OF THIS EQUIPMENT AND SHALL BE RATED 277 V (PHASE TO GROUND), 480 V (PHASE TO PHASE), SUITABLE FOR OVERVOLTAGE CATEGORY III, AND SHALL PROVIDE PROTECTION FOR A RATED IMPULSE WITHSTAND VOLTAGE PEAK OF 2.5 kV

The Type of branch circuit protection devices used for BREAKDOWN OF COMPONENT TEST is Nonrenewable Cartridge Fuse, Class _RK5.

As RK5 is the worst Case Type, any other Type can be used.

1	2	3	4	5	6	7	8	9	10	11	12
---	---	---	---	---	---	---	---	---	----	----	----

10.5.2 Homologation CL (Version en française)

Température ambiante maximale:

Électronique	Adaptateur	Ambiente	Suffixe
INV M A IV02 PW02	ADP MA WDM	45° C	-
INV M A IV02 PW03	ADP MA WDM	45° C	-
INV M A IV02 PW04	ADP MA WDM	45° C	-
INV M A IV02 PW05	ADP MA WDM	40° C	-
INV M A IV02 PW90	ADP MA WDM	- *	-
INV M A IV01 PW03	ADP MA WDM	40° C	-
INV M A IV01 PW04	ADP MA WDM	40° C	-
INV M A IV01 PW05	ADP MA WDM	40° C	-
INV M A IV01 PW06	ADP MA WDM	40° C	-
INV M B IV01 PW07	ADP MB WDM	45° C	-
INV M B IV01 PW08	ADP MB WDM	40° C	-
INV M B IV01 PW09	ADP MB WDM	35° C	-
INV M C IV01 PW10	ADP MC WDM	40° C	GH01, GH02, GH07, GH93, GH95, GH4x
INV M C IV01 PW11	ADP MC WDM	35° C	GH01, GH02, GH07, GH93, GH95, GH4x
INV M C IV01 PW96	ADP MC WDM	35° C	GH01, GH02, GH07, GH93, GH95, GH4x
INV M C IV01 PW97	ADP MC WDM	20° C	GH01, GH02, GH07, GH93, GH95, GH4x
INV M C IV01 PW10	ADP MC WDM	55° C	GH04, GH96, GH5x
INV M C IV01 PW11	ADP MC WDM	50° C	GH04, GH96, GH5x
INV M C IV01 PW96	ADP MC WDM	50° C	GH04, GH96, GH5x
INV M C IV01 PW10	ADP MC WDM	50° C	GH05, GH97, GH6x
INV M C IV01 PW11	ADP MC WDM	45° C	GH05, GH97, GH6x
INV M C IV01 PW96	ADP MC WDM	45° C	GH05, GH97, GH6x
INV M D IV01 PW12	ADP MD WDM	55° C	-
INV M D IV01 PW13	ADP MD WDM	50° C	-
INV M D IV01 PW14	ADP MD WDM	40° C	-
INV M D IV01 PW15	ADP MD WDM	35° C	-

* dépend du refroidissement externe

Mentions requises

Boîtier prévu pour une utilisation avec entrées de conduit fileté installées sur le terrain, raccords ou plaques d'obturation approuvées UL conformément à UL514B et certifiées CSA conformément à C22.2 No. 18, étiquetage environnemental de type 1 ou plus.

La protection interne contre les surcharges se met en marche en l'espace de 60 secondes une fois 150 % du courant nominal du moteur atteints

Short circuit current rating (SCCR)

Convient pour une utilisation sur un circuit capable de livrer pas plus de 200 kA ampères symétriques rms, 230 volts pour INV Mx IV02 ou 480 volts pour INV Mx IV01 maximum en cas de protection par fusibles.

« Avertissement » – Utiliser des fusibles d'une valeur nominale de 600 V/50 A pour INV MA IV02 uniquement.

« Avertissement » – Utiliser des fusibles d'une valeur nominale de 600 V/10 A pour INV MA IV01 uniquement.

« Avertissement » – Utiliser des fusibles d'une valeur nominale de 600 V/30 A pour INV MB IV01 uniquement.

« Avertissement » – Utiliser des fusibles d'une valeur nominale de 600 V/30 A pour INV MC IV01 uniquement.

« Avertissement » – Utiliser des fusibles d'une valeur nominale de 600 V/70 A pour INV MD IV01 uniquement.

La protection intégrée contre les courts-circuits à semi-conducteur n'assure pas la protection du circuit de dérivation. Le circuit de dérivation doit être protégé conformément aux instructions du fabricant, au code national d'électricité et à tout autre code local additionnel.

Toutes les bornes de câblage avec repères pour les connexions correctes pour l'alimentation électrique, la charge et les circuits de commande.

Le couple de serrage pour la connexion des bornes du moteur est de 26,55 lb/in (taille A à C) et de 5,31 lb/in pour la connexion CTP (toutes les tailles).

Pour les instructions destinées à l'opérateur et les instructions de service relatives au montage et à la connexion des produits à l'aide de l'adaptateur de connexion du moteur prévu à cet effet, voir les chapitres 3.3 et 9.1 contenus dans le Manuel d'utilisation.

Utiliser uniquement des câbles en cuivre 75° C.

Les entraînements ne permettent pas la détection de surtempérature.

Concernant le Mx IV01 utilisé au Canada : LA SUPPRESSION DE TENSION TRANSITOIRE DOIT ÊTRE INSTALLÉE CÔTÉ LIGNE DE CET ÉQUIPEMENT ET AVOIR UNE VALEUR NOMINALE DE 277 V (PHASE-TERRE), 480 V (PHASE-PHASE), EN COMPATIBILITÉ AVEC LA CATÉGORIE DE SURTENSION III, ET DOIT OFFRIR UNE PROTECTION CONTRE UN PIC DE TENSION ASSIGNÉE DE TENUE AUX CHOCS DE 2,5 kV

Le fusible cartouche à usage unique de classe RK5 est le type de dispositifs de protection des circuits de dérivation utilisé pour l'ESSAI DE PANNE DES COMPOSANTS.

RK5 étant le type employé dans les scénarios catastrophes, n'importe quel autre type peut être utilisé.

11.Quickstart guide

11.1 Quickstart guide

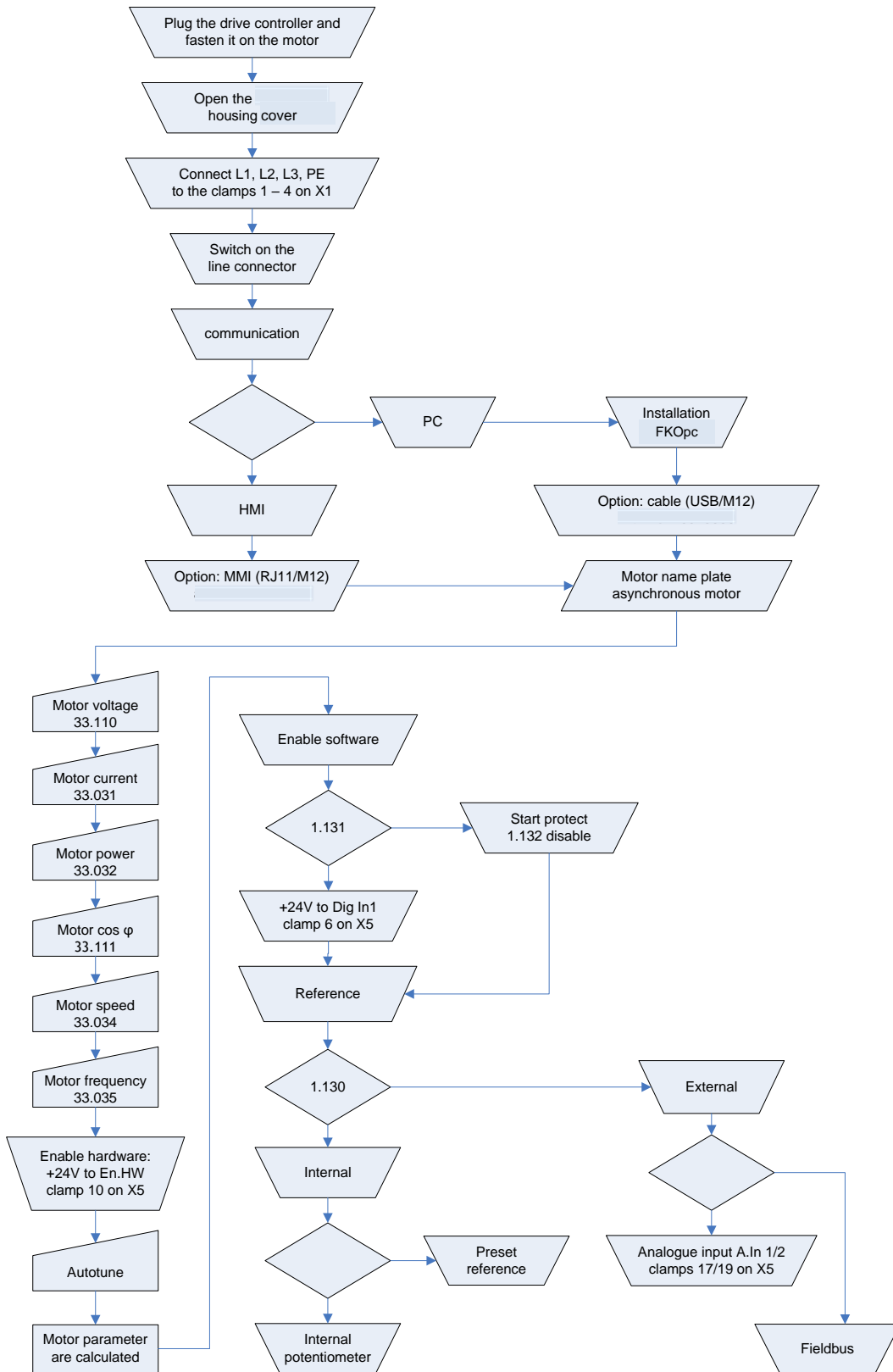

Fig. 49: Block diagram for quick start ASM

11.2 Quickstart guide for synchronous motors

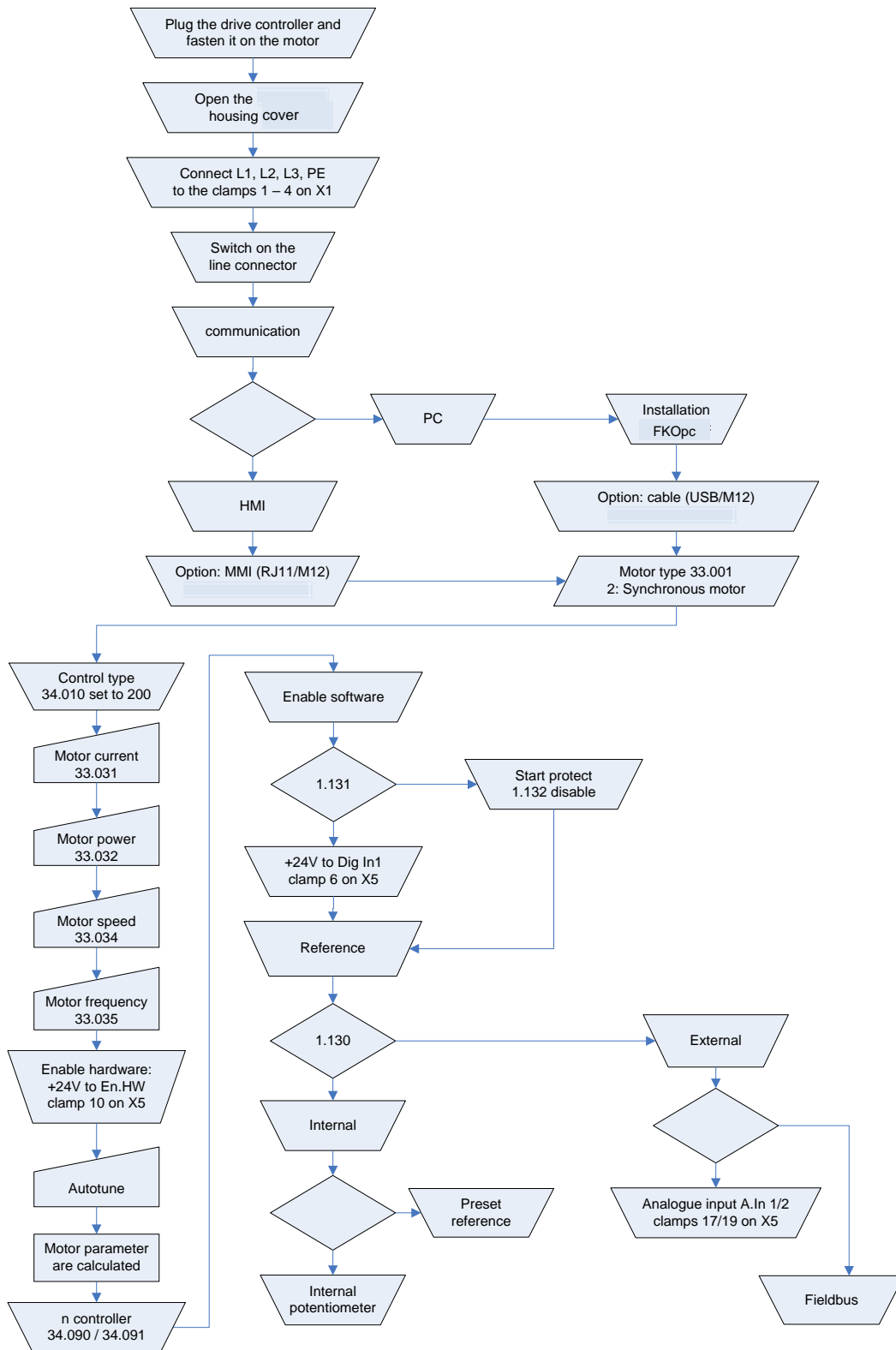

Fig. 50: Block diagram for quick start

1	2	3	4	5	6	7	8	9	10	11	12
---	---	---	---	---	---	---	---	---	----	----	----

12.Index

"

.....	87
-------	----

A

.....	70
Additional function	85
Ambient conditions	19
Ambient temperature.....	106
Analogue input	34, 75
Analogue output.....	34, 78
Application parameters	66
.....	70

B

Block diagram.....	58
Blocking detection.....	84
Brake chopper	33
Brake resistor	33

C

Cable screw connections.....	19, 33
Cable shoes.....	23, 43
.....	94
CE marking.....	11
Commissioning.....	56, 119
Commissioning steps	59
Communication	57
Connection diagram	38
Control connections.....	33
Control connections of the basic application board	37
.....	93
Control terminals (sizes A – D)	23
Controller data.....	93
Convection.....	39

D

Derating.....	106
Digital input	35, 37, 78
Digital output.....	36, 37, 79

E

Electrical connection	29
EMC limit classes.....	113
EMC standard	113
Enable software	68
Energy-saving function.....	63
Error detection.....	97, 100
Excess temperature.....	99, 100
External fault.....	83

F

Factory setting.....	65
Fan.....	19

FI protection switch.....	14
Field weakening.....	96
Fieldbus.....	87
Fieldbus address.....	88
Fixed frequency.....	64
Flying restart.....	94
Frequency.....	34
Frequency setting mode.....	62

G

Gearbox factor.....	84
General technical data for 230 V devices.....	103
General technical data for 400V devices.....	102
Grid connection.....	29
Ground protection.....	23

H

HMI Parameters.....	86
---------------------	----

I

I2t limit.....	93
Information about commissioning.....	13
Installation.....	20, 39, 110
Installation altitude.....	19, 107
Instructions concerning operation.....	14

L

Label on the drive controller.....	9
Leakage inductance.....	92
LED flash codes.....	97
Legal notice.....	2

M

Mains activations.....	15
Maximum frequency.....	66
Mechanical installation of size D.....	45
Mechanical installation of sizes A - C.....	40
Minimum frequency.....	66
MMI.....	57, 112
Motor cos phi.....	92
Motor current.....	91
Motor current limit.....	84
Motor frequency.....	91
Motor phase monitoring.....	91
Motor potentiometer.....	71
Motor rating.....	91
Motor speed.....	91
Motor voltage.....	90, 92

O

Operating mode.....	67
Optional accessories.....	110
Overcurrent.....	100
Overheating.....	99
Overload.....	98, 99
Overvoltage.....	98, 99

P

Parameter.....	61
----------------	----

Parameter set.....	98
Parameter set change.....	86
Parameterisation.....	59
PC cable.....	112
Performance parameters.....	90
PID inverted.....	62, 73
PID process control.....	62
PID process controller.....	72
Power connection for size D.....	31
Power connection for sizes A - C.....	29
Power connections (size D).....	25
Power connections (sizes A – C).....	24

Q

Quadratic characteristic curve.....	95
Quickstart guide.....	119

R

Ramp.....	66, 67
Relay.....	36, 80
Repairs.....	16
Rotation direction.....	69

S

Safety instructions.....	11, 18
Set bus timeout.....	89
Set field bus baud rate.....	88
Short circuit current rating (SCCR).....	116, 118
Slip.....	95
Speed.....	91
Speed controller.....	94
Standards.....	114
Star connection variant.....	22
Start-up procedure SM.....	96
Start-up protection.....	69
Stator inductance.....	90, 92
Stator resistance.....	91, 92
Switching frequency.....	93, 108
Synchronous motor controller data.....	96
System error.....	98

T

Target value source.....	68
Technical data.....	102
Transport & storage.....	13
Triangle connection variant.....	21

U

UL.....	115
Undervoltage.....	98, 99

W

Wall adapter plates.....	110
Wiring instructions.....	23

Notes

13. EC declaration of conformity

DEUTSCH / ENGLISH / FRANÇAIS / ESPAÑOL



EG-Konformitätserklärung

EC declaration of conformity / Déclaration de conformité CE / Declaración de conformidad CE

Hersteller / Manufacturer / Constructeur / Fabricante

Brinkmann Pumpen, K. H. Brinkmann GmbH & Co. KG
 Friedrichstraße 2, D-58791 Werdohl

Produktbezeichnung / Product name / Désignation du produit / Designación del producto

Antriebsregler / Drive control / Convertisseur de fréquence / Regulador de accionamiento

Typ / Type / Tipo **FKO / FKO PROFIBUS**

Das bezeichnete Produkt stimmt mit den folgenden Richtlinien des Rates zur Angleichung der Rechtsvorschriften der EG-Mitgliedsstaaten überein:

The named product conforms to the following Council Directives on approximation of laws of the EEC Member States:

Le produit sus-mentionné est conforme aux Directives du Conseil concernant le rapprochement des législations des Etats membres CEE:

El producto designado cumple con las Directivas del Consejo relativas a la aproximación de las legislaciones de los Estados Miembros de la CEE:

- 2014/35/EU** Niederspannungsrichtlinie
- 2014/35/EU** low voltage guide lines
- 2014/35/UE** Directive "Basse Tension"
- 2014/35/UE** Directivas de bajo voltaje

- 2014/30/EU** Richtlinie für elektromagnetische Verträglichkeit
- 2014/30/EU** Council Directive for Electromagnetic compatibility
- 2014/30/UE** Directive du Conseil pour Compatibilité électromagnétique
- 2014/30/UE** Directivas del Consejo para Compatibilidad electromagnética

- 2011/65/EU und 2015/863/EU** RoHS Richtlinien
- 2011/65/EU and 2015/863/EU** RoHS Directives
- 2011/65/UE et 2015/863/UE** Directives RoHS
- 2011/65/UE y 2015/863/UE** RoHS Directivas

Die Übereinstimmung mit den Vorschriften dieser Richtlinien wird nachgewiesen durch die vollständige Einhaltung folgender Normen:

Conformity with the requirements of this Directives is testified by complete adherence to the following standards:

La conformité aux prescriptions de ces Directives est démontrée par la conformité intégrale avec les normes suivantes:

La conformidad con las prescripciones de estas directivas queda justificada por haber cumplido totalmente las siguientes normas:

Harmonisierte Europ. Normen / Harmonised Europ. Standards / Normes europ. harmonisées / Normas europ. Armonizadas

EN 61800-3:2019-11 EN 61800-5-1 :2007 + A1 :2021 EN IEC 63000 :2018

Die Hinweise in der Betriebsanleitung für den Einbau und die Inbetriebnahme des Antriebsreglers sind zu beachten.

The instructions contained in the operating manual for installation and start up the drive control have to be followed.

Les indications d'installation / montage et de mise en service du convertisseur de fréquence prévues dans l'instruction d'emploi doivent être suivies.

Tenga en cuenta las instrucciones en el manual para la instalación y puesta en marcha del regulador de accionamiento.

Brinkmann Pumpen, K. H. Brinkmann GmbH & Co. KG

Werdohl, 24.04.2023

.....
 Dr.-Ing. Dirk Wenderott
 Chief Product Officer (CPO)
 Head of Engineering

Dr. H. Abou Dayé
 K. H. Brinkmann GmbH & Co. KG
 Friedrichstraße 2, D-58791 Werdohl
 Dokumentationsbevollmächtigter /
 Representative of documentation/
 Mandataire de documentation /
 Mandatario de documentación



BRINKMANN PUMPEN
K.H. Brinkmann GmbH & Co. KG
Friedrichstraße 2
58791 Werdohl
Germany
Tel. +49 (0)2392 5006-0
Fax +49 (0)2392 5006-180
sales@brinkmannpumps.de